

Mini-level float switches

Description **MSK2-PVC-R3/8-O 0075**

Article number **6891323029**

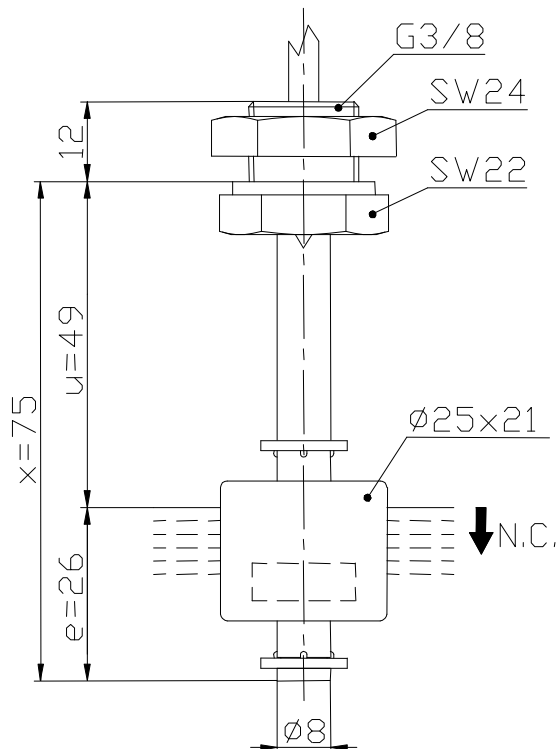

Performance diagram
(maximum data)

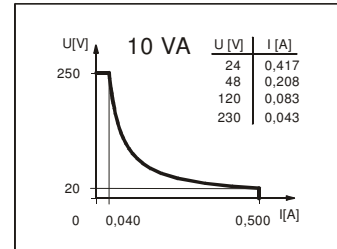

Wiring diagram
(matching to the drawing)

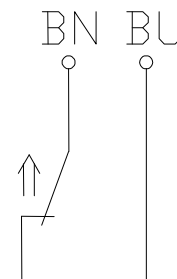

Electrical data

Reed contact	max. switching voltage	250 V
	max. switching current	0,5 A
	max. switching capacity	10 VA
	mechanical life	10 ⁷ to 10 ⁹ switches depending on the load
Switching element		1 normally closed contact, falling level
Direction category		AC-22A and DC-22A acc to DIN VDE 0660 T107
Standard		acc to DIN VDE 0660 T200

Mechanical data

Screw connection material	PVC
Hexagon nut material	PVC
Switching tube material	PVC
Float material	PVC
-density	about 0,7 g/cm ³ ±10%
-depth of immersion	15 mm ±2 mm (to a fluid-density of 1 g/cm ³)
Grip screw material	PVC
Gasket material	NBR
Ambient air temperature	-5 °C to +60 °C
Liquid temperature	-5 °C to +60 °C
Connection	3m cable, PVC, 2x0,34mm ²
Protection type	IP 65 acc to DIN VDE 0470 T1
Max. pressure	5 bar

General details

Repeatability of switching points is ±0,05mm based on the same geometrical conditions as of a switch device.
 The measures of the switching points refer to a fluid-density of 1 g/cm³.
 The tolerance of the switching points is ±2mm
 Pay attention to the contact protection, when switching inductive loads. Maximum data must not be exceeded!

Subject to change without notice.

Date of issue : 26.07.2006 / Page 1 of 1
 Document : 6891323029_en.doc / Last update : 3