

Technical Data

Float Switch

Standard float switches

Description **MSK6-MS-R1/2ST-SO-T70-O 0160**

Article number **6891260005**

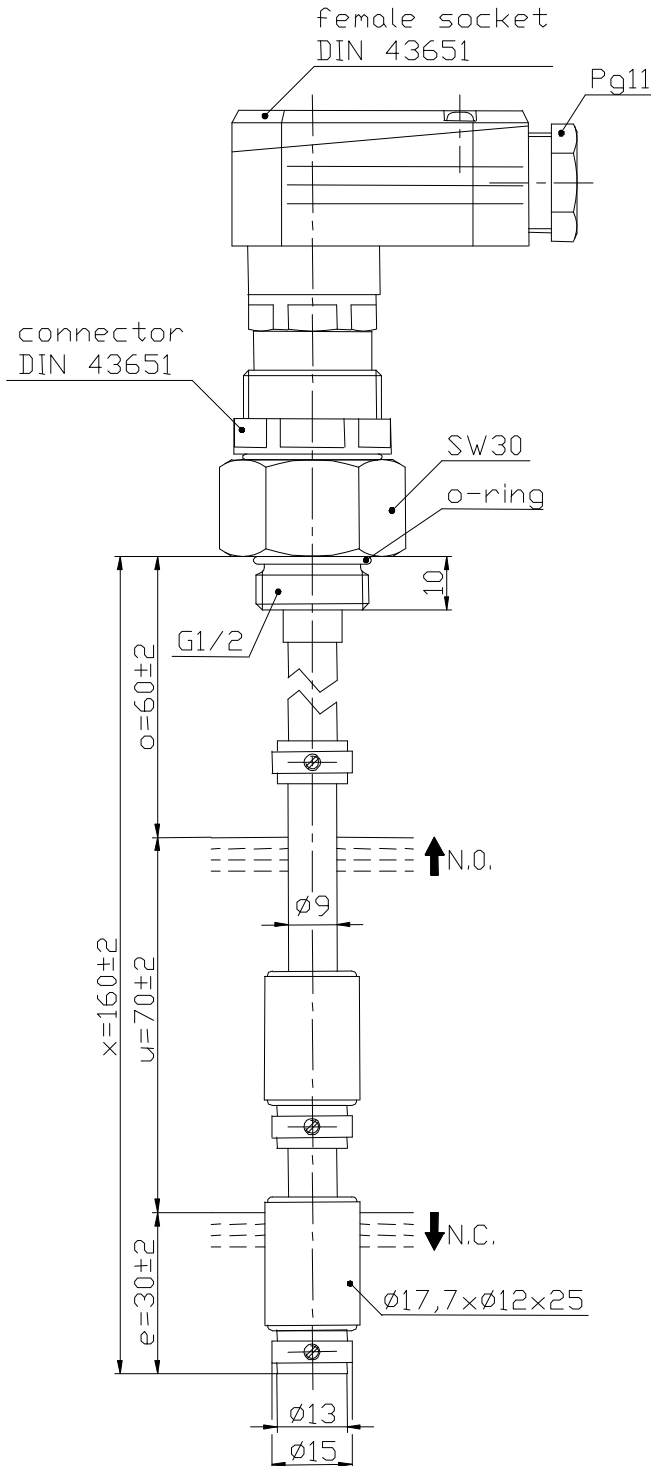

Performance diagram
(maximum data)

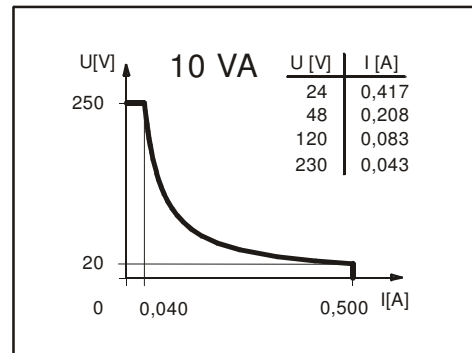

Wiring diagram
(without liquid)

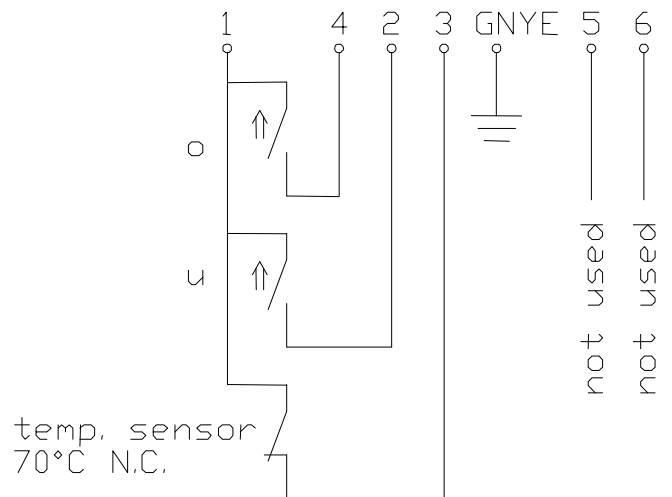

Subject to change without notice.

Date of issue : 18.06.2008 / Page 1 of 2
Document : 6891260005_en.doc / Last update : 4

Standard float switches

Description **MSK6-MS-R1/2ST-SO-T70-O 0160** Article number **6891260005**

Electrical data

		Normally open contact	Possible is also: Change over contact / Normally closed contact
Reed contact			
Reed contact	max. switching voltage	250 V	100 V
	max. switching current	0,5 A	0,5 A
	max. switching capacity	10 VA	5 VA
	mechanical life	10 ⁷ to 10 ⁹ switches depending on the load	
temp. sensor	max. switching voltage	250 V	
	max. switching current	2,5 A	
	max. switching cycle	10000	
	switching temperature range	70°C normally closed contact	
	standard switching tolerance	±5°C	
	standard reset temperature	40°C ±15°C	
Switching element		1 normally open contact, rising level 1 normally closed contact, falling level 1 temp. sensor, normally closed contact 70°C	
Direction category		AC-22A and DC-22A acc. to DIN VDE 0660 T107	
Standard		acc. to DIN VDE 0660 T200	

Mechanical data

Screw connection material	CuZn39Pb3 (2.0401)	
Switching tube material	CuZn37 (2.0321)	
Float material	NBR	
	-density	about 0,5 g/cm ³ ±10%
	-depth of immersion	18 mm ±2 mm (to a fluid-density of 1 g/cm ³)
Adjusting ring material	CuZn39Pb3 (2.0401)	
Gasket material	NBR	
Ambient air temperature	-5°C to +80°C	
Liquid temperature	-5°C to +80°C	
Connection	plug-in connection acc. to DIN 43651	
Protection type	IP 65 acc. to DIN VDE 0470 T1 <u>only with female socket</u>	
Max. pressure	5 bar	

General details

Repeatability of switching points is ±0,05mm based on the same geometrical conditions as of a switch device.

The measures of the switching points refer to a fluid-density of 1 g/cm³.

The tolerance of the switching points is ±2mm

Pay attention to the contact protection, when switching inductive loads. Maximum data must not be exceeded!