

Foot-switch Series F2 UN

Description **F2-SU1Z/SU2ZDR UN**

Article number **6162000316**

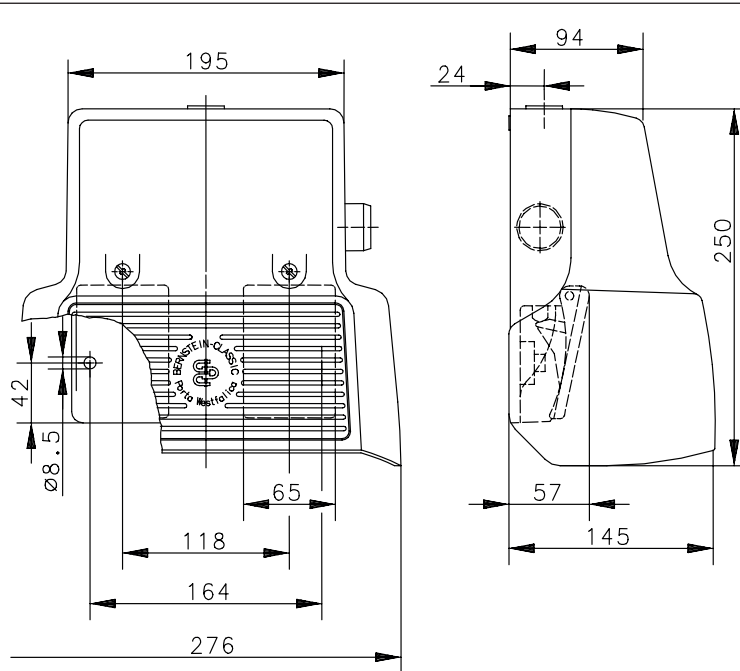

Switching symbol

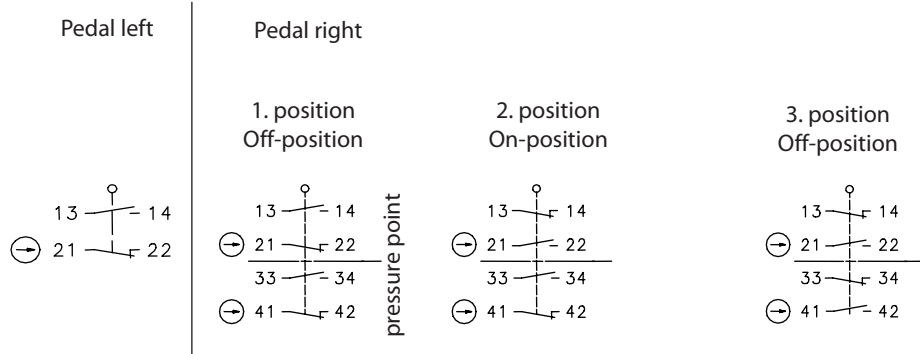

Operating diagram

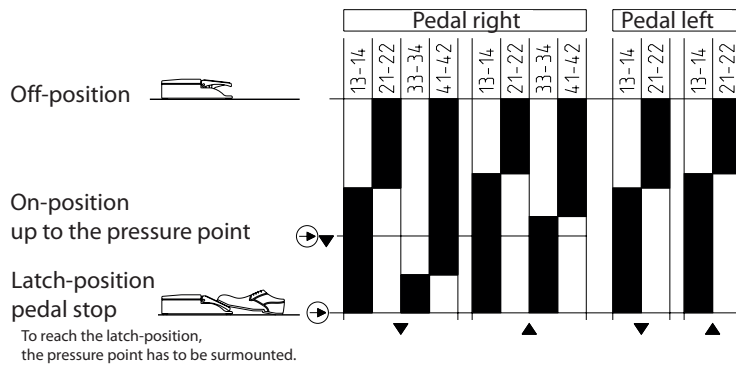

Notes

The degree of protection specified (IP code) applies only to a properly closed protective guard and the use of an equivalent cable gland with adequate cable.