

Foot-switch Series F1

Description **F1-U1Y**

Article number **6161100432**

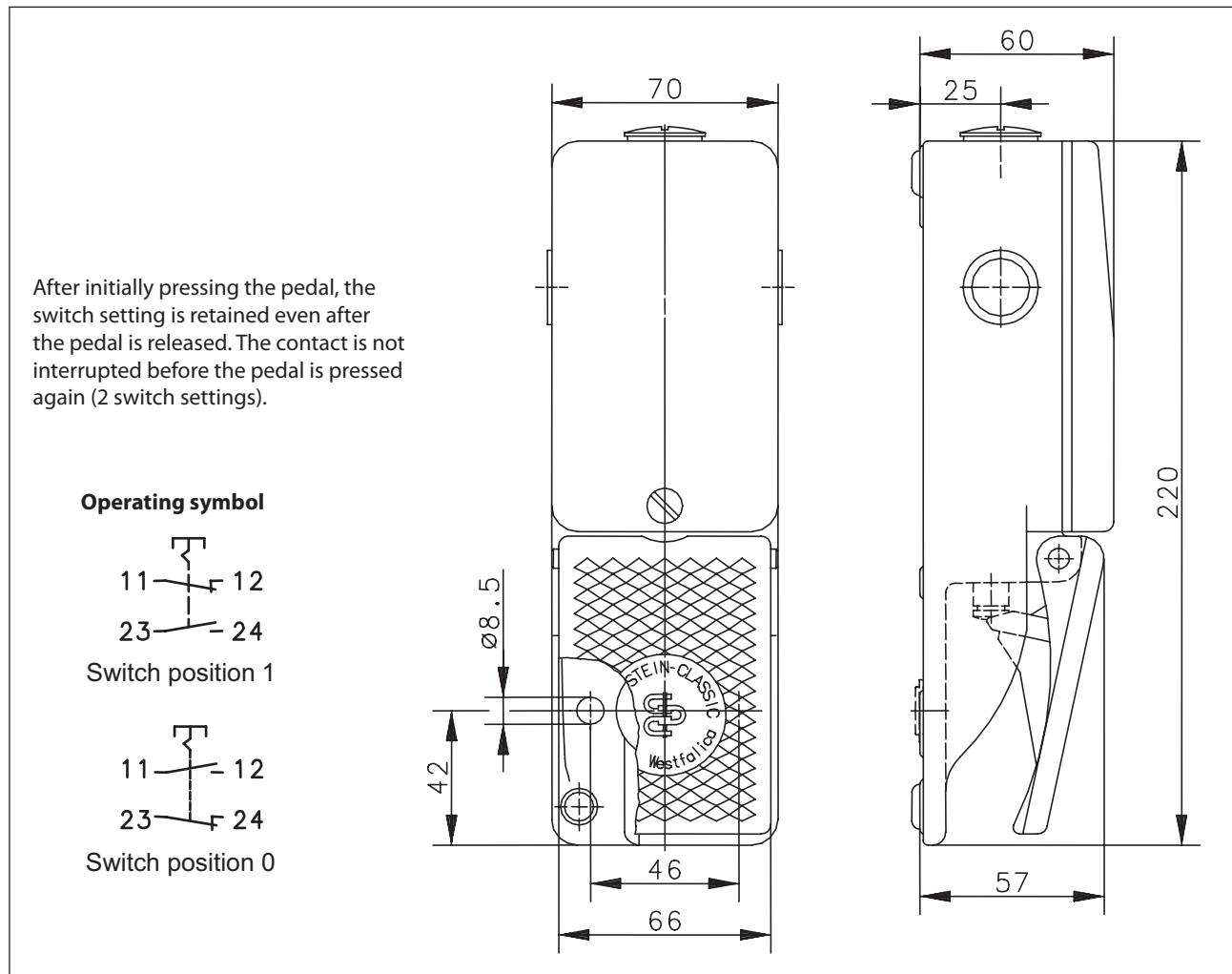

Electrical data

Rated insulation voltage	U_i	400 V AC
Conv. thermal current	I_{the}	10 A
Rated operational voltage	U_e	240 V
Utilization category		AC-15, U_e 240 V / I_e 3 A
Short-circuit protective device		Fuse 10 A gG
Protection class		I

Mechanical Data	
Enclosure	AL
Cover	AL
Actuator	Foot lever (PA)
Ambient air temperature	-30 °C ... +80 °C
Contact type	1 N.C. / 1 N.O. (Zb) with latching
Operating force	≈ 10 N (pedal centre)
Mechanical life	1 x 10 ⁶ switching cycles
Switching frequency	≤ 50/min
Assembly	2 x M8
Connection	Screw connections (M3,5)
Number of connections	4
Protection ground	2 x M4
Conductor cross-sections	Solid: 0,5 ... 1,5 mm ² Litz wire with ferrules: 0,5 ... 1,5 mm ²
Cable entry size	3 x M20 x 1,5
Weight	≈ 0,6 kg
Protection type	IP 65 acc. to IEC/EN 60529

ID for safety engineering	
B10d	2 x 10 ⁶ cycles

Standards	
	DIN EN 60947-5-1
	DIN EN ISO 13849-1

EU Conformity	
	acc. to directive 2014/35/EU (Low-Voltage-Directive)

Approvals	
	DGUV
	cCSA _{US} A300 (same polarity)
	CCC

Notes	
The specified protection classification (IP code) applies only when the cover is closed and and in connection with the appropriate cable gland.	