

Bearbeitung der Montagefläche/
Machining of the mounting surface/
Usinage de la surface de montage

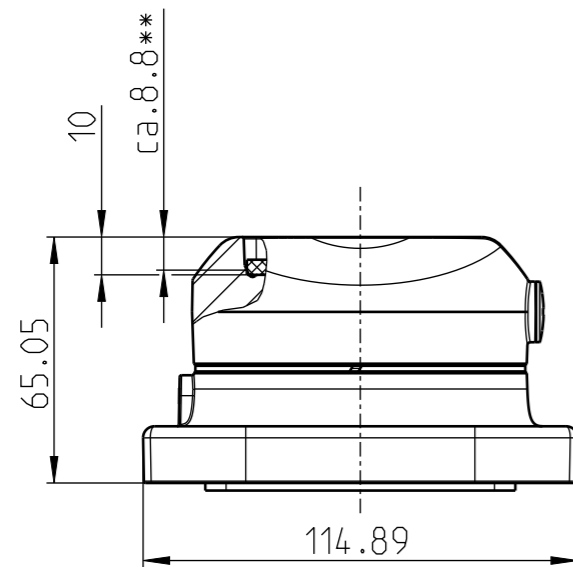

A-A

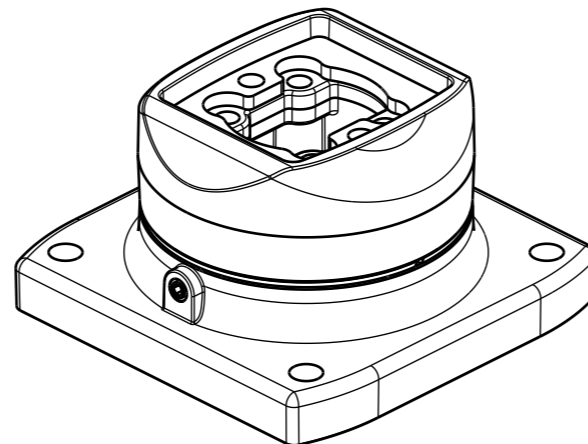
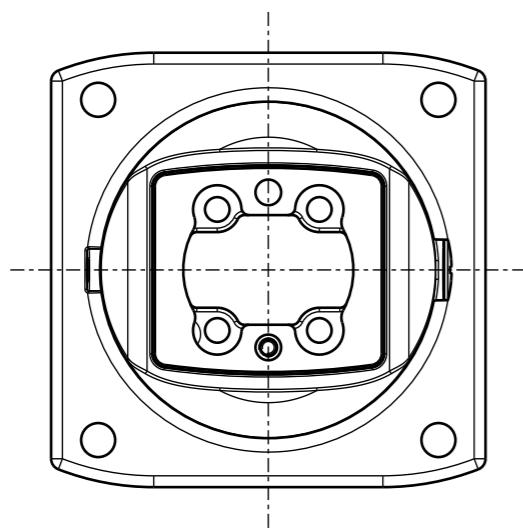
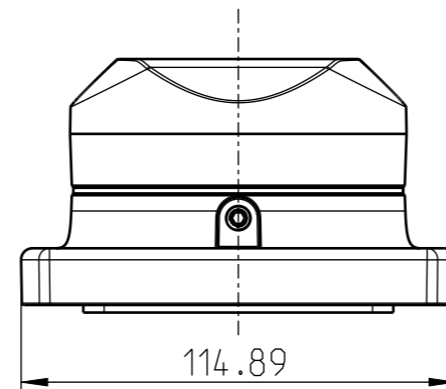

* = Maße der Kabelführung/
Cable guide dimensions/
Dimensions du guide-câble
** = Einschubtiefe vom Tragrohr/
Insertion depth of the support tube
Profondeur d'insertion du tube support

Mitteilungsnummer/Notice number		BERNSTEIN Bernstein AG Postfach 1164 D-32437 Porta Westfalica www.bernstein.eu	Masse ohne Toleranzangabe/General tolerances	
Entwicklungsnummer/Development number			ISO 2768-mH	
Umgearbeitet aus/Manufactured out of		Erstellt/Drawn by		Oberfläche/Surface
Passend zu/Matched with		24.07.2023 FSc		RAL9006
Mst./Scale		Geprüft/Checked by		Werkstoff/Material
1:2		12.12.2023 DBr		
A3		Freigegeben/Approved by		Gewicht ca./Weight approx.:
		12.12.2023 FSc		0.84901 kg
Benennung/Part Name			Blatt/Sheet	
CS-B.light Standfuss drehbar			1 / 1	
CS-B.light base rotary			Modell/Model	
			1	
			Zeichnung/Drawing	
			1	
			Nummer/Drawing No.	
			1015500021	