

Bearbeitung der Montagefläche/
Machining of the mounting surface/
Usinage de la surface de montage

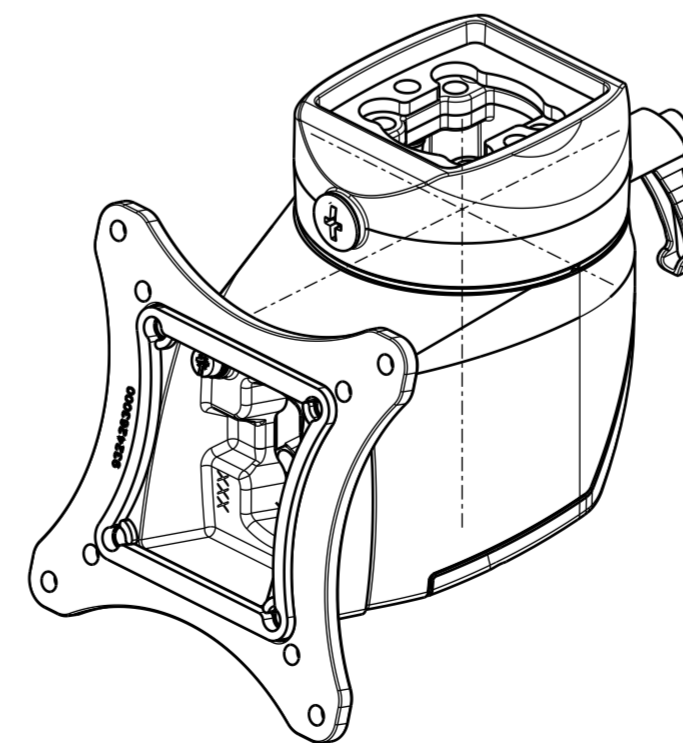
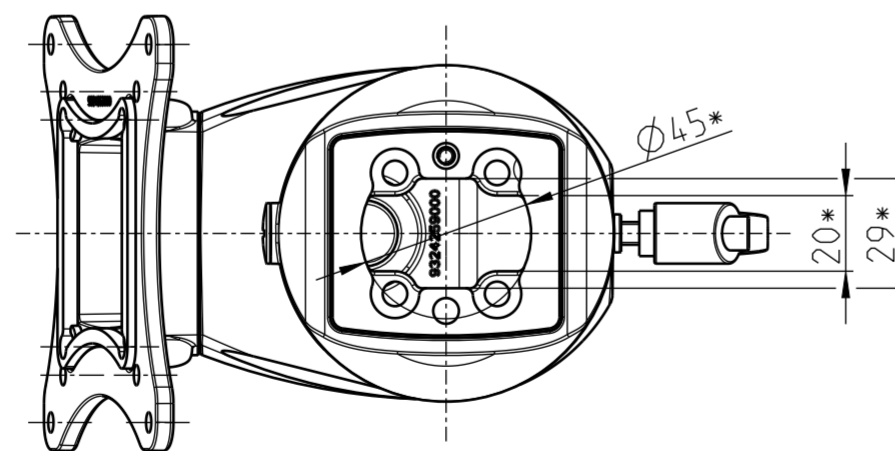
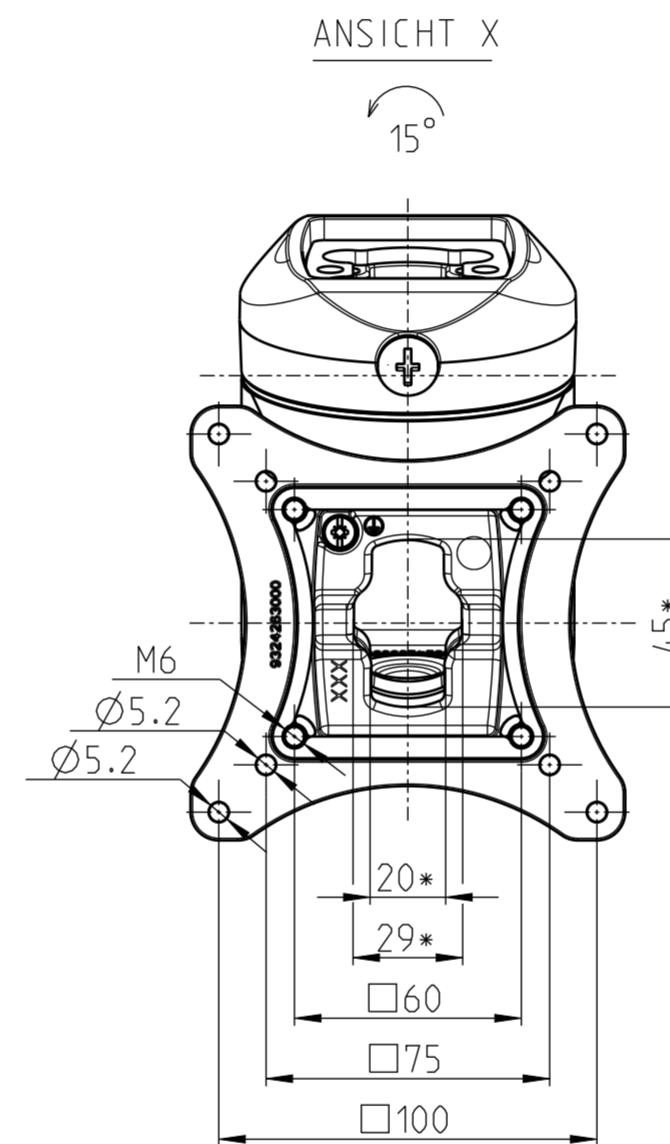
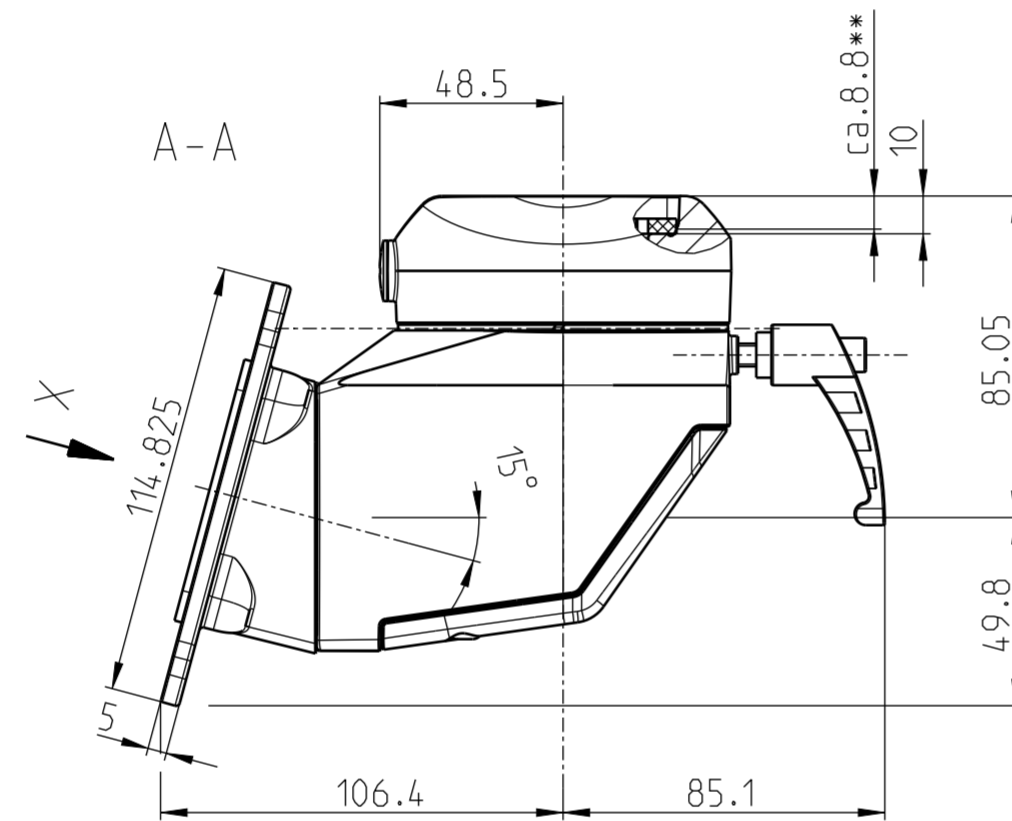
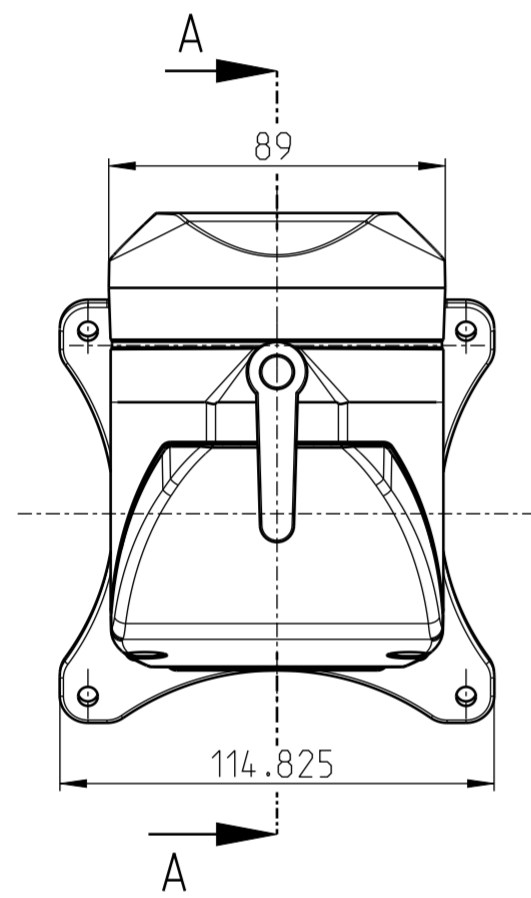

- * = Maße der Kabelführung/
Cable guide dimensions/
Dimensions du guide-câble
- ** = Einschubtiefe vom Tragrohr/
Insertion depth of the support tube
Profondeur d'insertion du tube support

Mitteilungsnummer/Notice number		BERNSTEIN Bernstein AG Postfach 1164 D-32437 Porta Westfalica www.berstein.eu	Masse ohne Toleranzangabe/General tolerances	
Entwicklungsnummer/Development number			ISO 2768-mH	
Umgearbeitet aus/Manufactured out of		Erstellt/Drawn by		Halbzeug/Semifinished part
Passend zu/Matched with		15.11.2023 FSc		Oberfläche/Surface
Mst./Scale		Geprüft/Checked by		Werkstoff/Material
1:2		12.12.2023 DBr		
A2		Freigegeben/Approved by		Gewicht ca./Weight approx.:
		12.12.2023 FSc		1.40573 kg
Benennung/Part Name		Nummer/ Drawing No.		Blatt/Sheet
CS-B.Light Panelkupplung S. 15°		1015500011		1 / 1
CS-B.light panel coupling S. 15°				Modell/ Zeichnung/ Model/ Drawing
				1 / 1