

Bearbeitungszeichnung für Montagefläch
Machine drawing for mounting surface

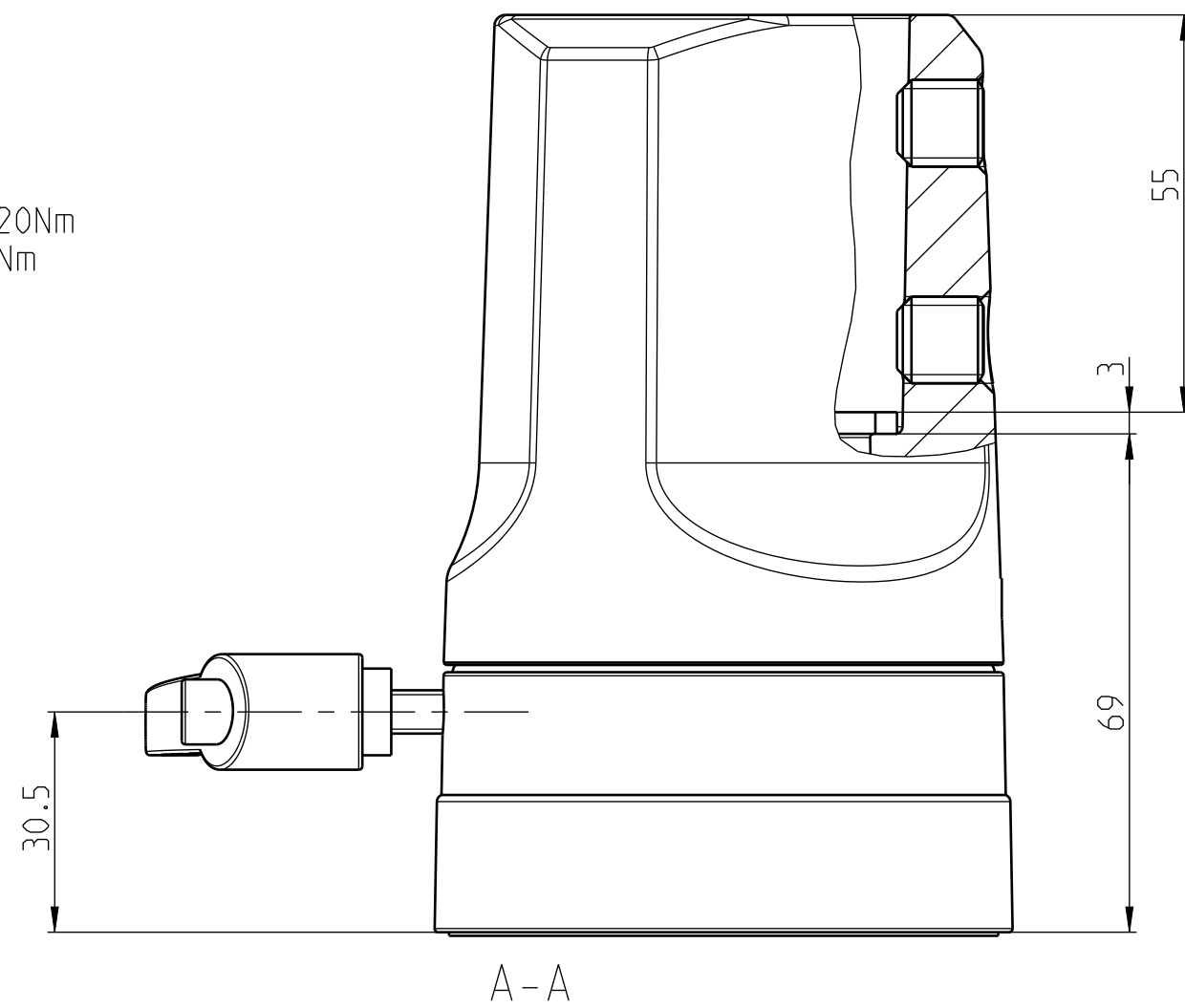
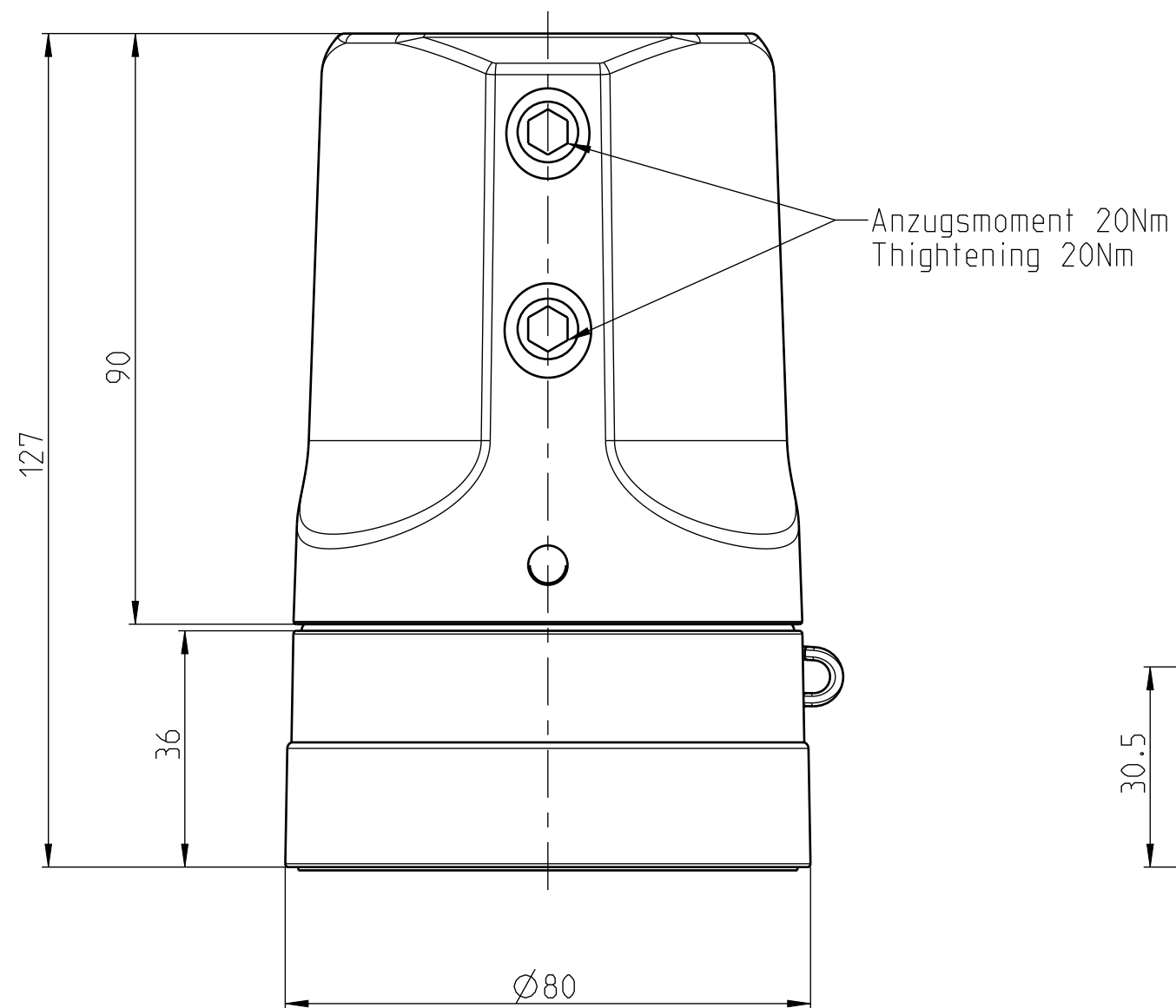

Mitteilungsnummer/Notice number		BERNSTEIN		Masse ohne Toleranzangabe/General tolerances	
Entwicklungsnummer/Development number		Bernstein AG Postfach 1164 D-32437 Porta Westfalica www.berstein.eu		Halbzeug/Semifinished part	
Umgearbeitet aus/Manufactured out of		Erstellt/Drawn by 13.03.2019 R.Wentland		Oberflaeche/Surface Farbe RAL 9006 /Colour RAL 9006	
Passend zu/Matched with		Geprueft/Checked by 25.03.2019 F.Schömbner		Werkstoff/Material	
Mst./Scale 1:1	A2	Freigegeben/Approved by 25.03.2019 R.Wentland		Gewicht ca./Weight approx.: 0.95487 kg	Blatt/Sheet 1 / 1
Benennung/ Part Name CS-480 B.flex Kupplung CS-480 B.flex coupling			Nummer/ Drawing No. 1014800001 KD		Modell/ Model 4 Zeichnung/ Drawing 4