

Bearbeitungszeichnung für Montagefläche

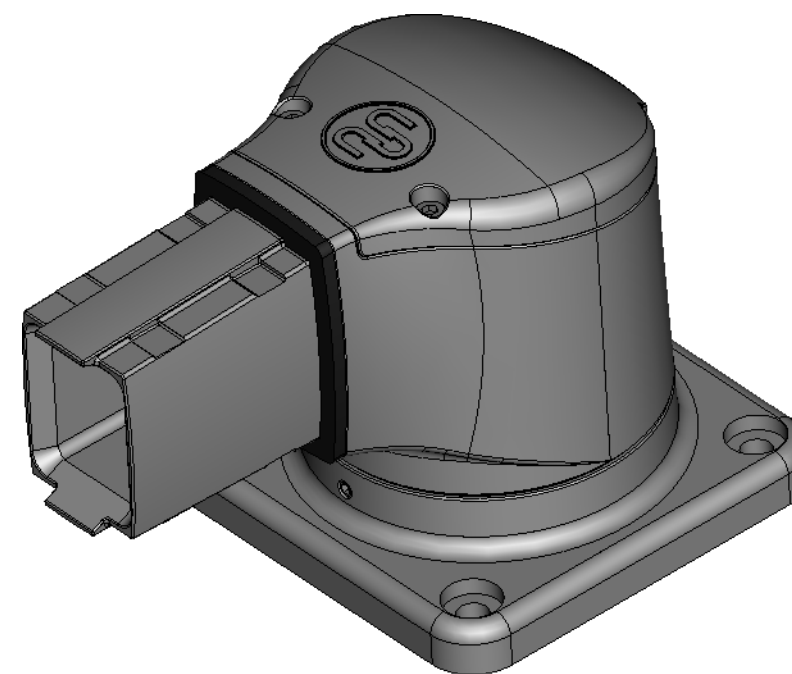
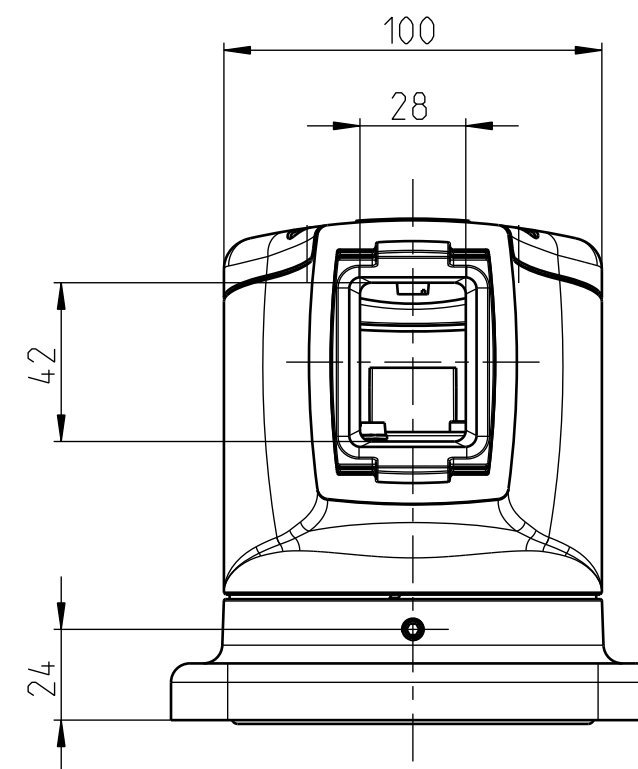
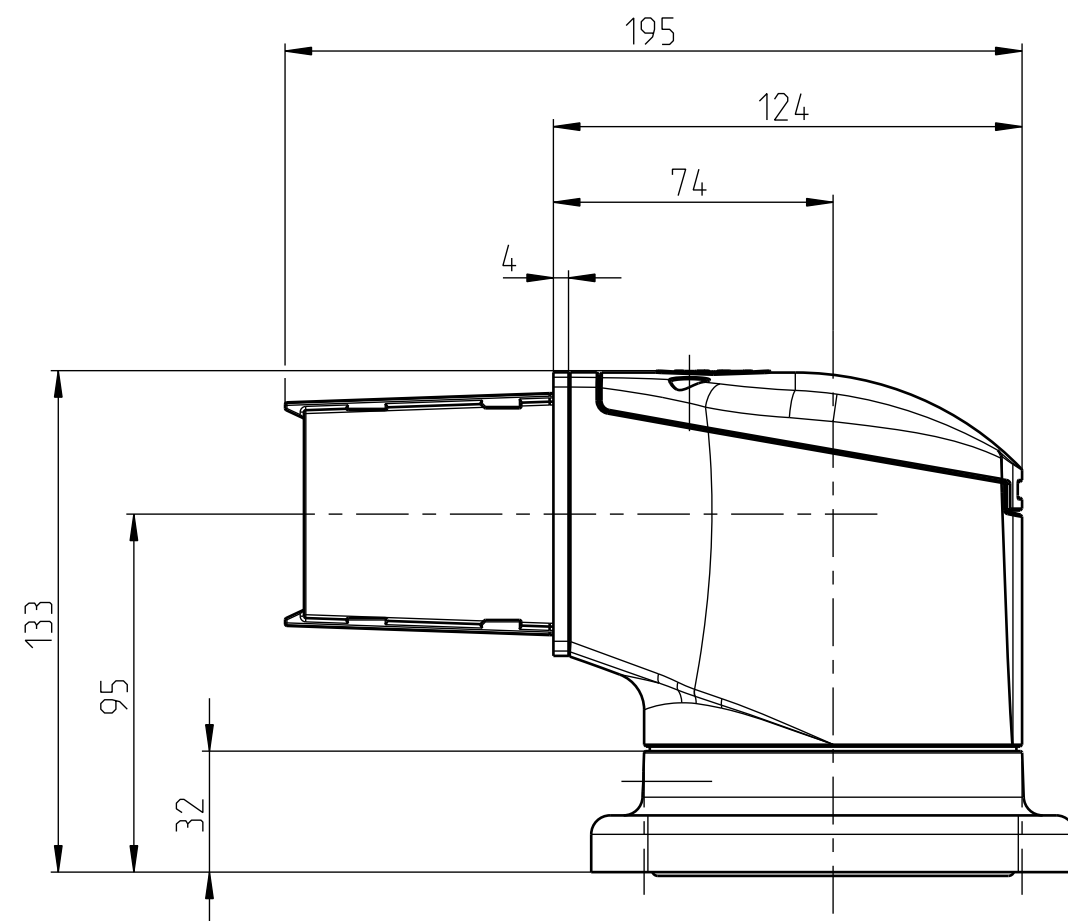

Mittellingsnummer/Notice number		 Bernstein AG Postfach 1164 D-32437 Porta Westfalica www.bernstein.eu	Masse ohne Toleranzangabe/General tolerances	
Entwicklungsnummer/Development number			ISO 2768-mH	
Umgearbeitet aus/Manufactured out of		Erstellt/Drawn by		Halbzeug/Semifinished part
Passend zu/Matched with		10.09.2014 F.Schömbner		Oberfläche/Surface
-		Geprüft/Checked by		Werkstoff/Material
Mst./Scale		13.10.2014 S.Hoppe		Gewicht ca./Weight approx.:
1:2		Freigegeben/Approved by		Blatt/Sheet
A2		13.10.2014 F.Schömbner		1 / 1
Benennung/Part Name			Nummer/ Drawing No.	Modell/ Model
CS-3000neXt Aufsatzgelenk			1017300014 KD	1
CS-3000neXt top joint				1