

Bearbeitungszeichnung für Montagefläche

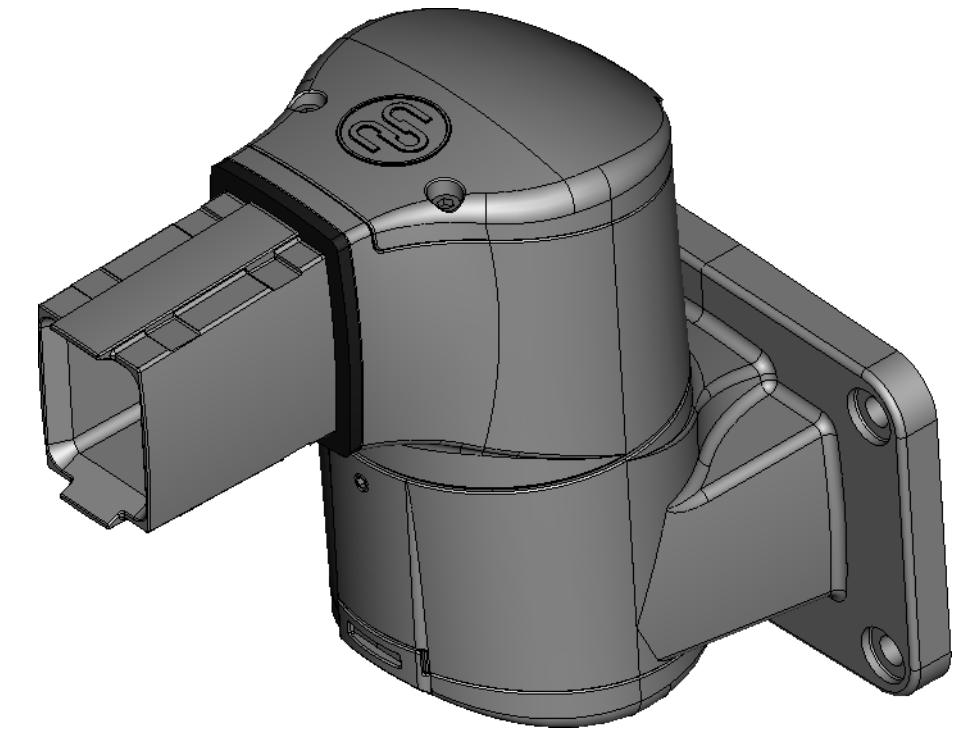
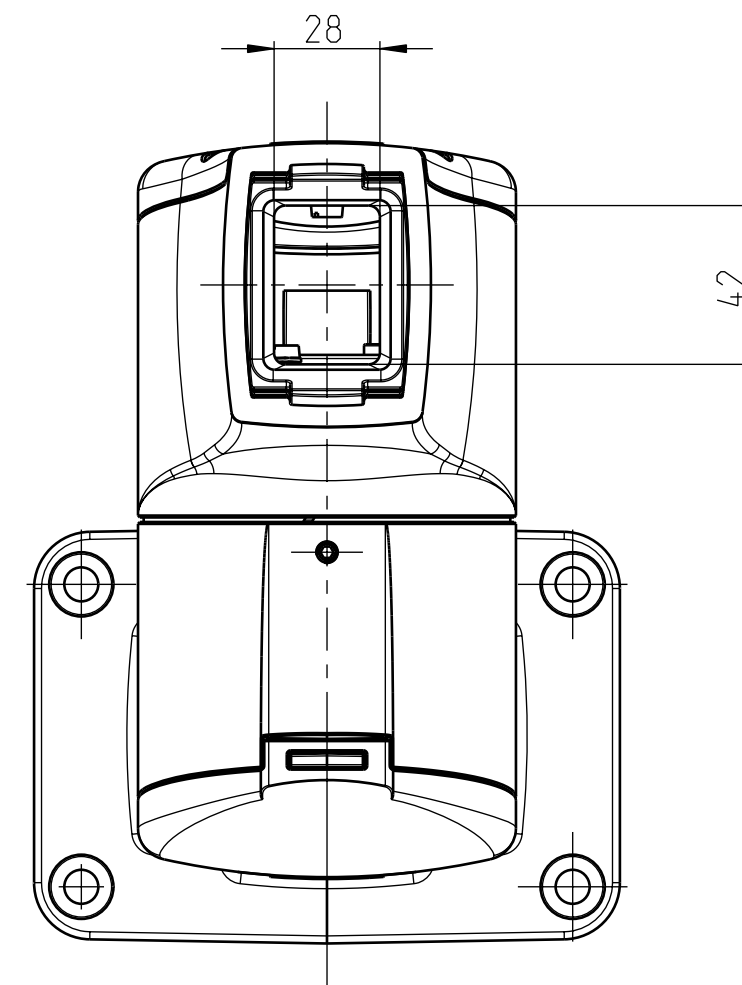
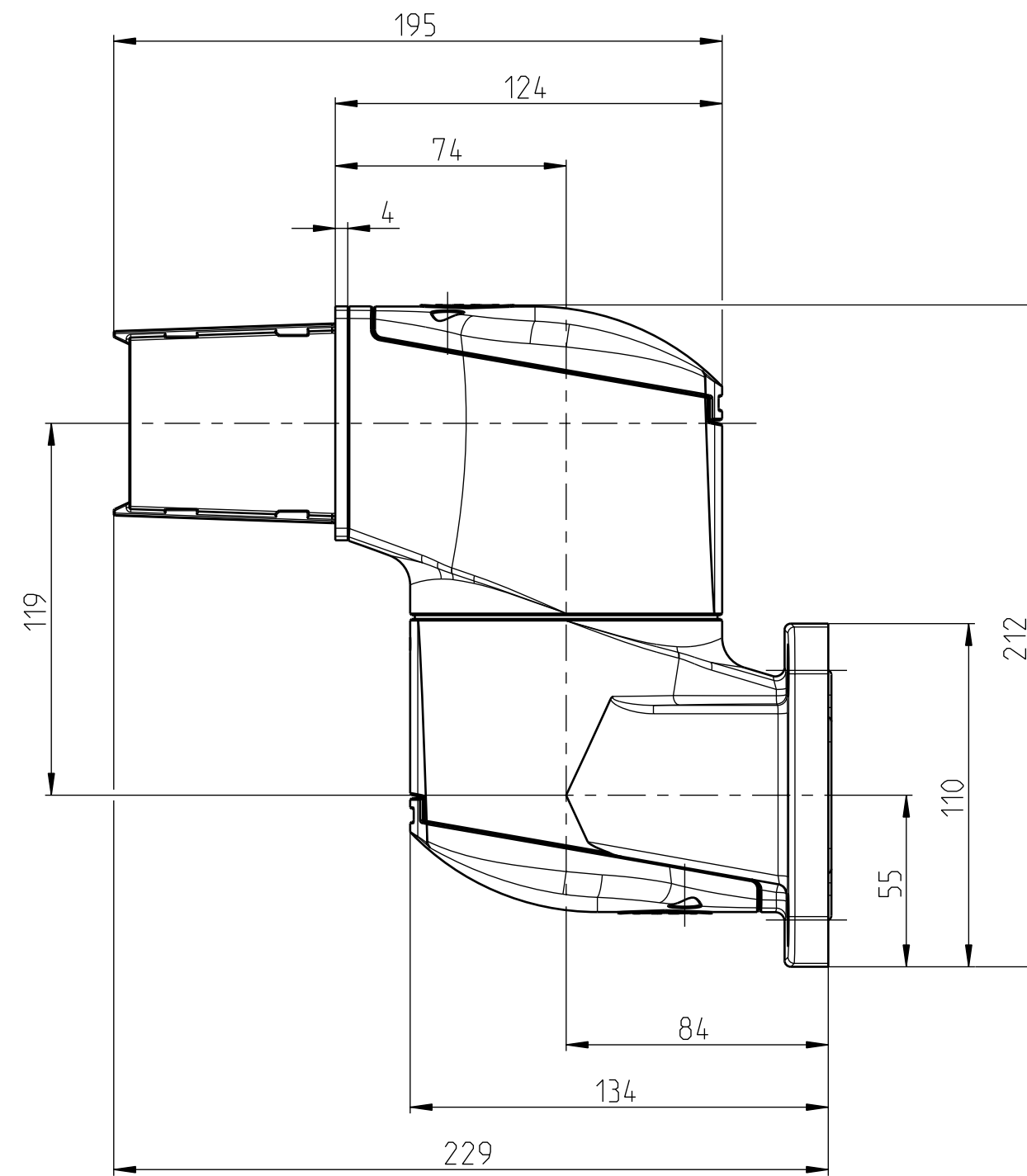
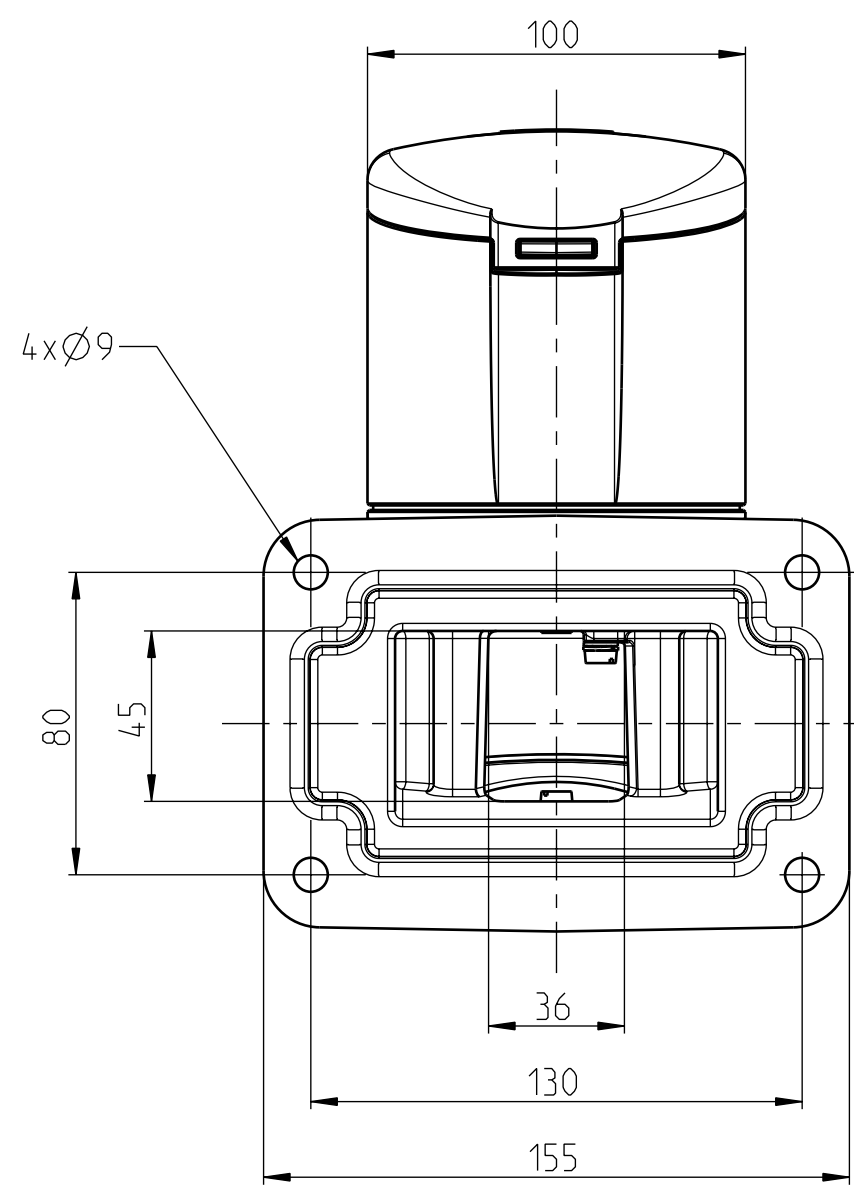

Vorlage : 0850172266_0rig_2

Mittellingsnummer/Notice number		 BERNSTEIN Bernstein AG Postfach 1164 D-32437 Porta Westfalica www.bernstein.eu	Masse ohne Toleranzangabe/General tolerances	
Entwicklungsnummer/Development number			ISO 2768-mH	
Umgearbeitet aus/Manufactured out of		Erstellt/Drawn by		Halbzeug/Semifinished part
Passend zu/Matched with		10.09.2014 F.Schömbner		Oberfläche/Surface
-		Geprüft/Checked by		Werkstoff/Material
Mst./Scale		22.10.2014 M.Fehring		Gewicht ca./Weight approx.:
1:2		Freigegeben/Approved by		Blatt/Sheet
A2		23.10.2014 F.Schömbner		1 / 1
Benennung/Part Name			Nummer/Model	Modell/Model
CS-3000neXt Wandgelenk W			1017300012 KD	1
CS-3000neXt wall joint W				1