

Bearbeitungszeichnung für Montagefläche

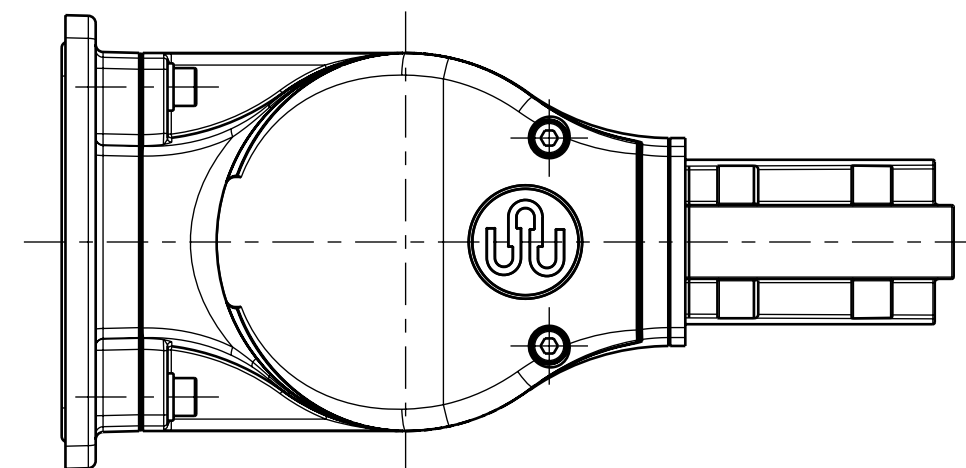
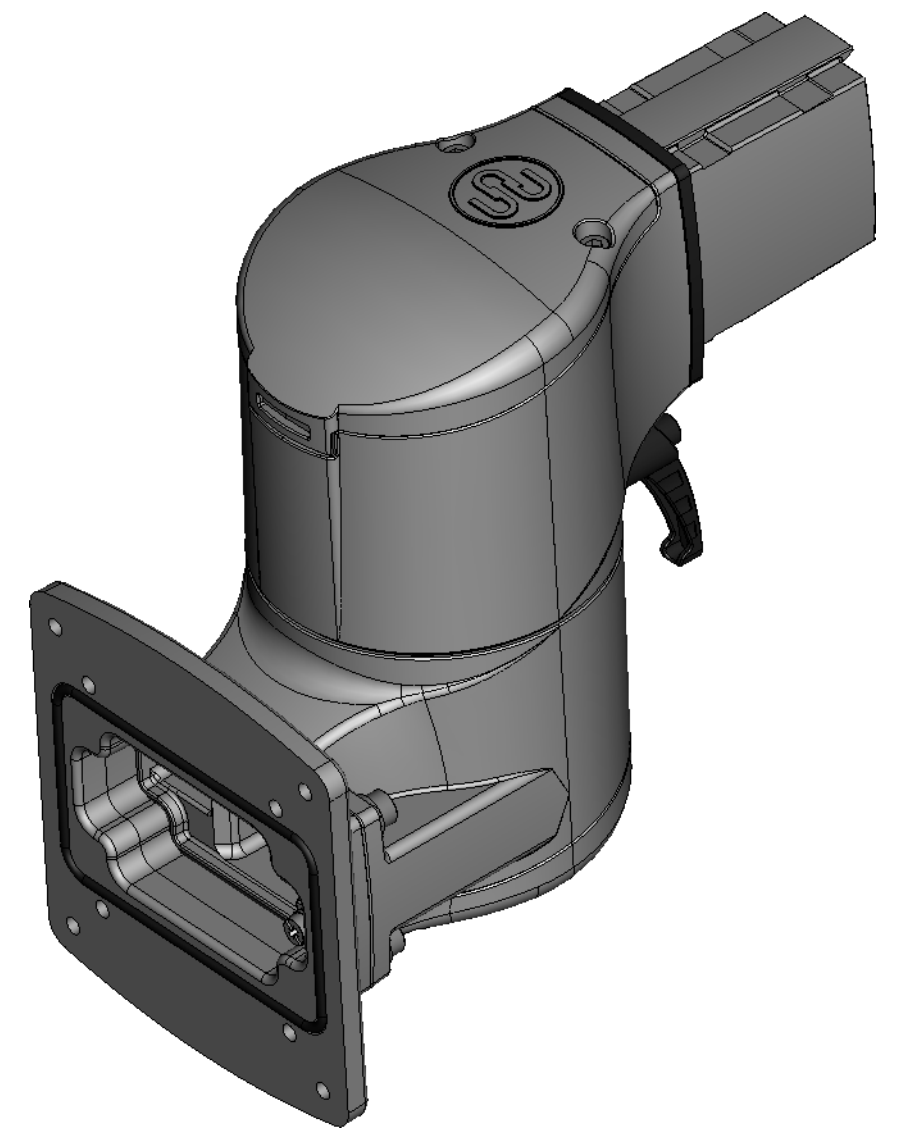
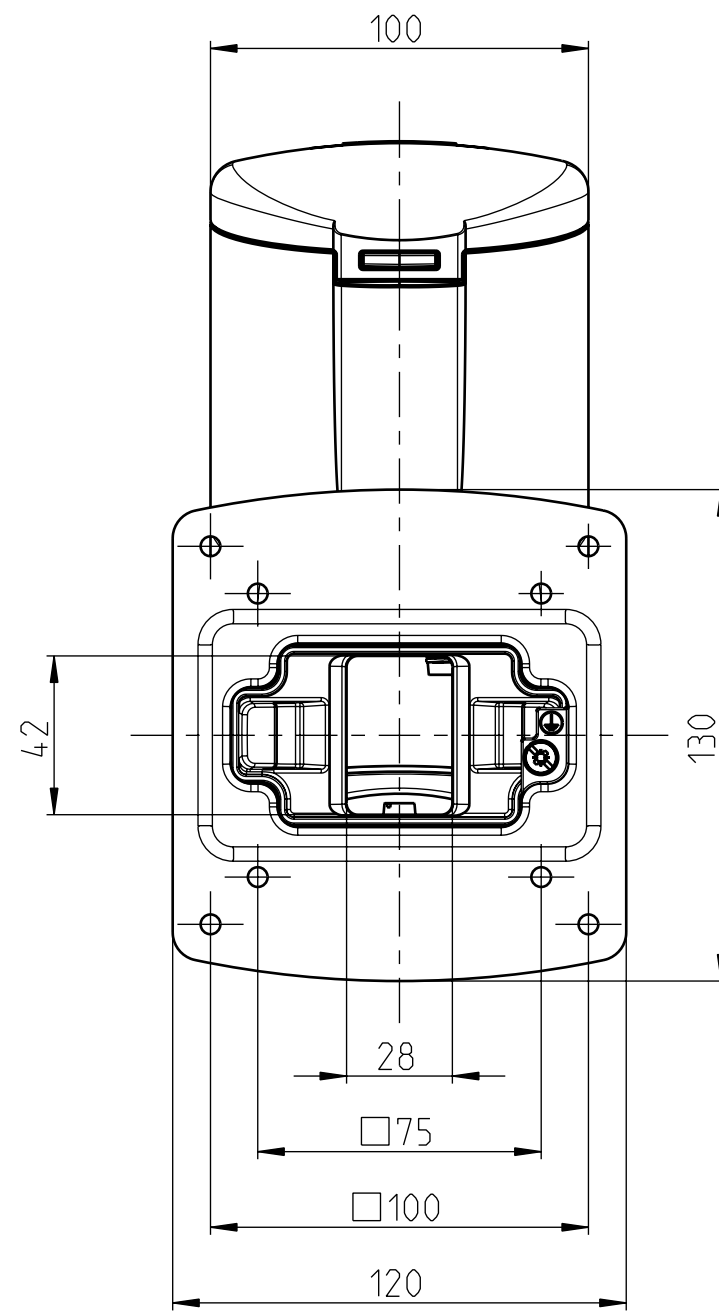
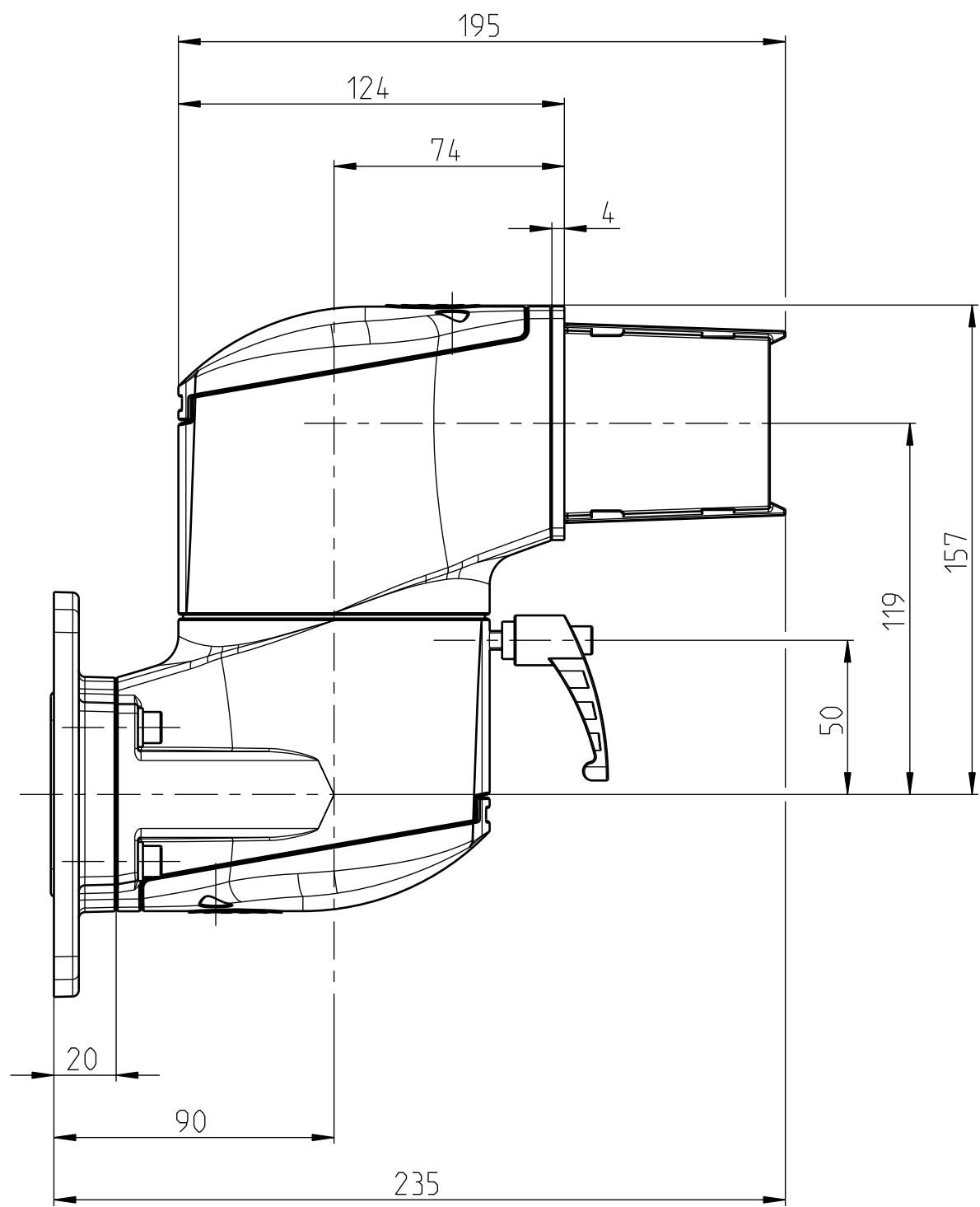
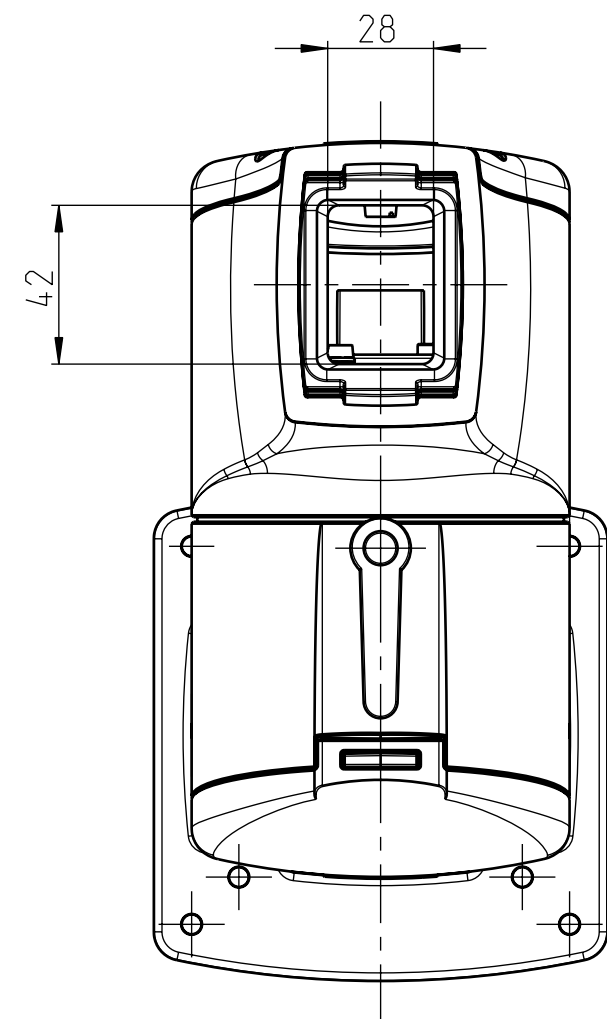

Mitteilungsnummer/Notice number		 BERNSTEIN Bernstein AG Postfach 1164 D-32437 Porta Westfalica www.bernstein.eu	Masse ohne Toleranzangabe/General tolerances	
Entwicklungsnummer/Development number			ISO 2768-mH	
Umgearbeitet aus/Manufactured out of		Erstellt/Drawn by		Halbzeug/Semifinished part
Passend zu/Matched with		10.09.2014 F.Schömbner		Oberfläche/Surface
-		07.10.2014 M.Fehring		Werkstoff/Material
Mst./Scale	A2	Freigegeben/Approved by		Gewicht ca./Weight approx.:
1:2		08.10.2014 F.Schömbner		2.96489 kg
Benennung/Part Name			Nummer/ Drawing No.	Blatt/Sheet
CS-3000neXt Panelkupplung W			1017300005 KD	1 / 1
CS-3000neXt panel coupling W				1 1