



Operating and monitoring

Industry meets ergonomics

INTRODUCTION

Industry meets ergonomics

BERNSTEIN showcases its future-oriented workplaces

Fixed movement sequences, uniform workstations and rigid controls that demand forced and unnatural working postures from employees are increasingly a relic of bygone times in industry today.

The operator of a machine should be able to adapt the working environment to their individual body dimensions, body forces and requirements. That is why, in addition to the flawless functionality of our solutions, we pay particular attention to ergonomics in accordance with DIN ISO 33402-2 when developing new products. Standing, turning, angling, tilting or hanging: BERNSTEIN offers the right, and above all, individual solution for every requirement that its customers may have.



WHAT IS AN OPERATOR STATION?

An HMI (Human Machine Interface) is the most important tool with which operators and responsible persons observe, coordinate and control the production processes in a factory. The operator station is therefore at the heart of every industrial plant. It is the place where man and machine communicate with each other, where information, inputs and commands are bundled and directly influence the production process.





OUR SERVICE

When you choose an operator station from BERNSTEIN, you not only get a solution that is optimally tailored to your application, but also the all-round package of quality, service and our passion.

Our specialists have the answers to your questions and solutions to your challenges. We particularly enjoy crafting customised applications – just ask us!



CONTENTS



OPERATING ENCLOSURE

- 8 CC-5000 neXt**
- 14 CC-4000 / CC-4000 SL**
- 22 CC-3000**
- 28 Accessories operating enclosure**

SUSPENSION SYSTEMS

- 34 CS-4000 neXt**
- 44 CS-3000 neXt**
- 58 CS-3000**
- 72 CS-2000 System 80**
- 84 CS-480 B.flex**
- 94 CS-480 NR**
- 102 Height-adjustable operator stations: ergo.flex**
- 108 Quick adjustment: ergo.slide**
- 118 Stand base: flex.base**

126 INDUSTRIAL OPERATOR STATIONS

Modular aluminium operating enclosure CC-5000

neXt

The aluminium operating enclosure CC-5000 neXt is a unique design featuring a number of accessories such as the status light. The rounded contours ensure that the enclosure is highly recognisable in machinery and mechanical engineering applications. Dimensions are of up to a maximum 1000 mm in height and width, with possible installation depths from 53 to 334 mm.

Product features

- Design industrial enclosures for demanding applications
- High-quality extruded aluminium sections (natural anodised)
- Corner module RAL 9006, white-aluminium (standard)
- Free colour design according to customer requirements
- Integrated handle elements
- Protection class IP 65
- Temperature range – 30 °C to + 80 °C
- Option: Slim version for visualisation applications
- Individual processing of front panels



Dimensions & variants

- Constructive design for max. external dimensions 1,000 mm x 1,000 mm
- Minimum internal dimensions width x height: 277 mm x 377 mm
- Installation depth 53 mm to 334 mm
- Optional: combination of 2 single frames
- Optional: version as console enclosure (2 inclination angles)

Application examples



Operating enclosure CC-5000^{next}

- VESA connection
- Front panel with cut-out for IPC



Operating enclosure CC-5000^{next} with IPC, operating surface and keyboard drawer

- Front panel with cut-out for IPC
- Operating surface with holes for command devices
- Keyboard drawer



Operating enclosure CC-5000^{next}

- Sloping console version
- Front panel with cut-out for IPC
- With status lamp
- With keyboard



Operating enclosure CC-5000^{next} with IPC and operating surface

- Vertical console version
- Front panel with cut-out for IPC
- Operating surface with holes for command devices
- With keyboard

Hinge



- Hinge integrated in the design
 - Not recognisable as a hinge when closed
 - Unique on the market
-

Rear panel



- Hinged variant
-



- Screwed variant
 - (optional connection to panel coupling)
-

Door centring system



- Door centring by a door lifter
 - Not visible when closed
 - Ensures the exact fit/closing of the door
-

Optional status light



- Status light integrated in the design (RGB LED)
-

Console version

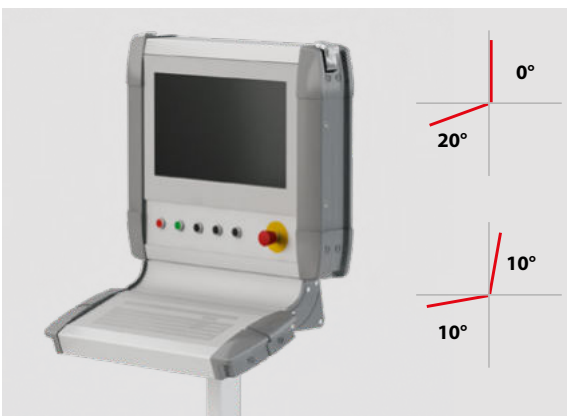

- Encapsulation of the keyboard in a separate enclosure
 - Combination into a compact unit
 - Inclination of the keyboard enclosure by 20° (operating enclosure vertical) or 10°
-

OPERATING ENCLOSURE CC-5000 next

Individual frames







External dimension	Internal dimension	Horizontal section	
75 mm	53 mm		
125 mm	103 mm		
185 mm	163 mm		

Double frames (see vertical handle sections figure)

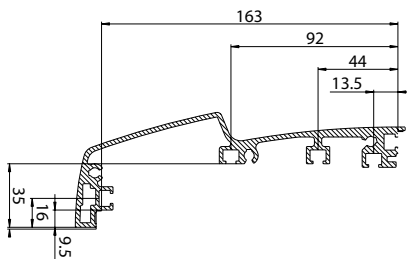
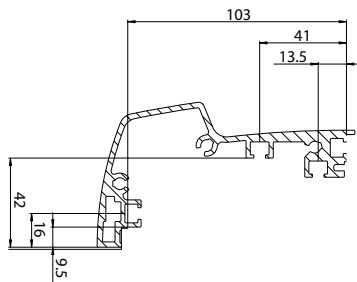
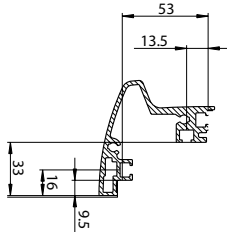

External dimension	Internal dimension	Vertical section
150 mm (75 + 75)	114 mm	
200 mm (75 + 125 or 125 + 75)	164 mm	
250 mm (125 + 125)	214 mm	

Vertical (handle) section

External dimension	Internal dimension	Vertical section
260 mm (75 + 185 or 185 + 75)	224 mm	
310 mm (125 + 185 or 185 + 125)	274 mm	
370 mm (185 + 185)	334 mm	

Modular aluminium operating enclosures CC-4000 and CC-4000 SL

With its technical features, the CC-4000/CC-4000 SL encapsulates and protects industrial controllers, industrial PCs and operating panels for centralised and decentralised automation in technological processes. The width and height can be freely selected up to a maximum of 800 x 800 mm. The possible depths range from 52 mm to a maximum of 646 mm. For swivelling the enclosure to the position desired by the operator, all sections are equipped with an integrated ergonomic handle. The CC-4000 SL has an elegant and slim profile design and makes the customer's entire machine or installation look modern and dynamic.

The CC-4000 and CC-4000 SL are designed for higher mechanical loads.

Product features

- Simple design based on extruded aluminium sections
- Integrated handle elements in vertical section
- Free colour choice according to customer requirements
- Protection class IP 65
- Temperature range – 30 °C to + 80 °C
- Optional console version
- Individual processing of front panels

Dimensions & variants

- Maximum external dimensions width x height: 800 mm x 800 mm
- Depth 52 mm to 646 mm
- SL variant: slim version in depths 55 mm + 99 mm
- Optional: console enclosure version (30 ° inclination)



Application examples



Operating enclosure CC-4000/SL

Console version

with console roller

- To connect the top and bottom parts of the console
- Stepless adjustment from 0° – 30°
- Suspended version only console base
- Standing version console top and bottom part

Operating enclosure CC-4000/SL console version

with console connector

- To connect the top and bottom parts of the console
- Rigid elements
- 30° inclination of the console base

Operating enclosure CC-4000/SL as upper part of a workstation

with coupling

- Coupling 90° rotatable
- With stop

OPERATING ENCLOSURE CC-4000 / CC-4000 SL



Ergonomically shaped handle elements for safe handling

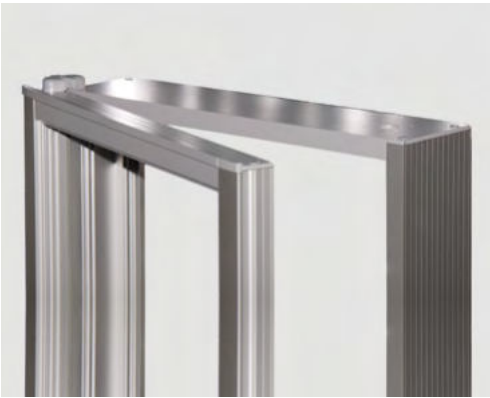

Opening the enclosure CC-4000 from the front with swivelling door section

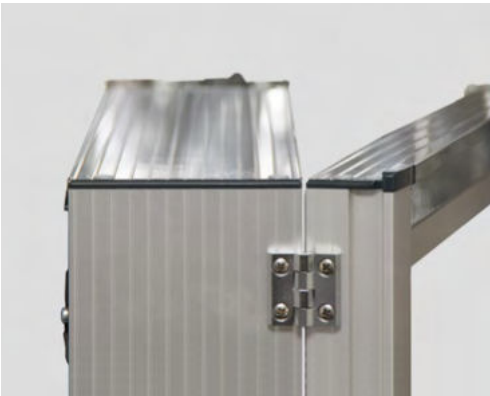

Different enclosure depths possible due to the combination of frame and extension sections



It is possible to open the CC-4000 enclosure and unhook the entire frame section at the outer joints



Wide range of mounting options due to circumferential fastening grooves



New keyboard drawer



Interfaces and RFID card reader in the side section



Assembly and wiring

OPERATING ENCLOSURE CC-4000 / CC-4000 SL

Front section CC-4000

External dimension	Internal dimension	Horizontal section	
52 mm	38 mm		
80 mm	66 mm		
140 mm	106 mm		
200 mm	186 mm		
290 mm	276 mm		

Partition



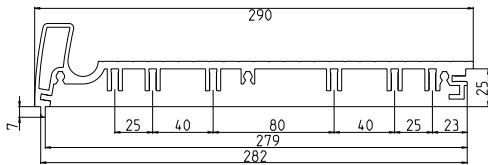
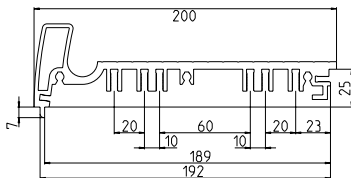
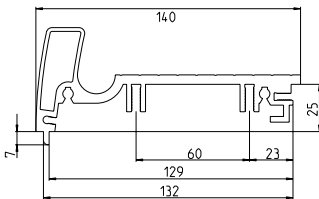
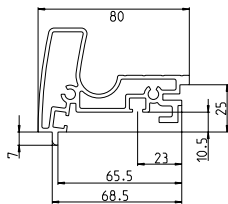
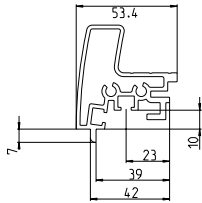

to section 52, 55, 80, 99 mm		
------------------------------	--	--

Vertical (handle) section

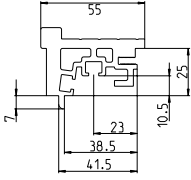

OPERATING ENCLOSURE CC-4000 / CC-4000 SL

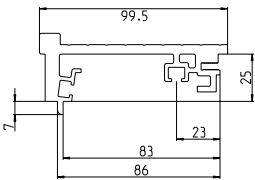
Front section CC-4000 SL

External dimension	Internal dimension	Horizontal section
55 mm	35 mm	 
99 mm	79 mm	 

Extension section for front section CC-4000

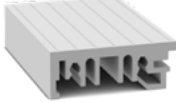
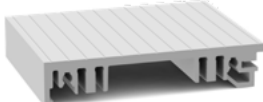
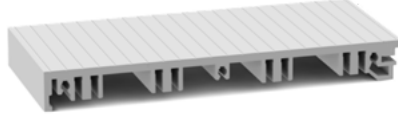
External dimension	Internal dimension	Horizontal and vertical section
68 mm	68 mm	
128 mm	128 mm	
228 mm	228 mm	

Vertical (handle) section

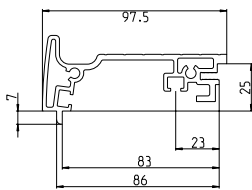
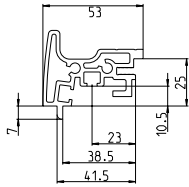

Hinged rear panel on frame section

Modular aluminium light-duty operating enclosure CC-3000

The CC-3000 is particularly suitable for encapsulating control panels, industrial computers and display components. It can be freely ordered in height and width up to a maximum recommended dimension of approx. 600 x 600 mm. By combining the two aluminium sections (120 mm and 200 mm) with the additional door section (55 mm), different enclosure depths are possible. BERNSTEIN offers sections in standard and handle versions.

Product features

- Sections optionally with or without handle strip (see page 22)
- Extruded aluminium sections + die-cast corners (standard RAL 9006)
- Sections, front panels, rear panels natural anodised
- Free colour choice according to customer requirements
- Protection class IP 65
- Temperature range – 30 °C to + 80 °C
- Rear panel fixed with screws or swivelling
- Individual processing of front panels
- Maximum external dimensions width x height: 600 mm x 600 mm



Application examples

Operating enclosure CC-3000

- With built-in IPC
- Connection from above to the CS-3000 suspension system

Operating enclosure CC-3000

- With front panel
- Built-in partition
- Partial front panel with controls
- Keyboard drawer
- Connection from below to **ergo.flex** with adapter plate

Operating enclosure CC-3000 with IPC and operating surface

- Front panel with machining for IPC
- Partition
- Front panel with processing for command devices
- Partition
- Keyboard drawer
- Signal light

Operating enclosure CC-3000 Bottom connection on CS-480 B.flex System

- Front panel with push-button module
- Signal lamp

OPERATING ENCLOSURE CC-3000

Handles / Sections

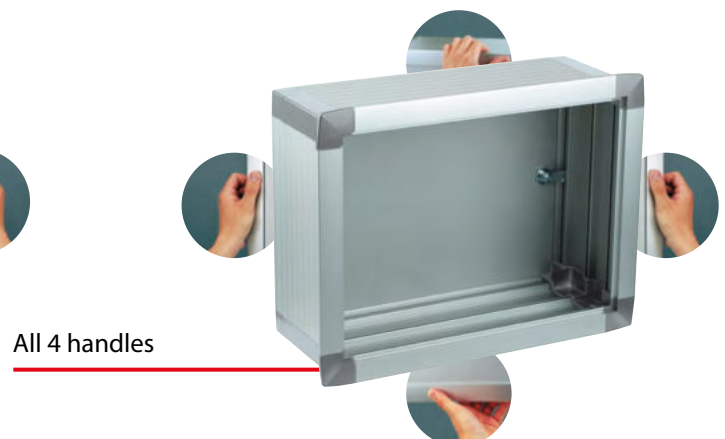
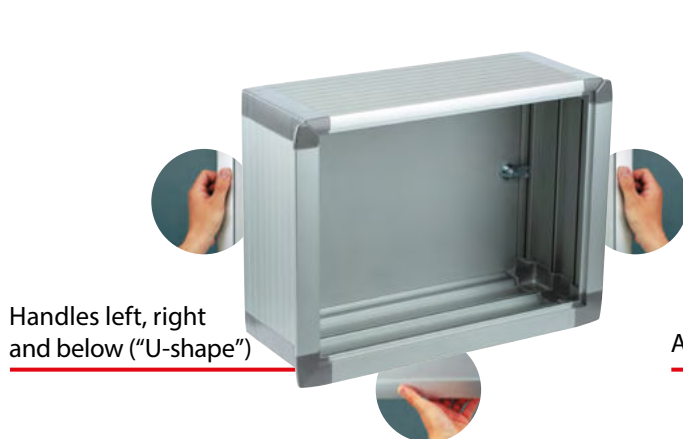

In addition to the width, the height and depth can be freely selected:

- Door hinge mounted on left or right
- Machining of the enclosures for mounting suspension systems
- Colour of corner modules
- Ready-to-use front panels according to customer specifications (incl. screen print or engraving)
- Specific preparation and wiring



Rear panel / front panel



Fixed rear panel



Hinged rear panel with lock

The rear panel can be screwed down or configured as a door. The door version is used with hinges or articulated hinges and the installation space is not restricted.



Internally-mounted front panel

BERNSTEIN offers a practical assembly system to make installation simple – machining of the front plate is not necessary in this case. The fixing elements can easily be moved inside the enclosure, making it easier for the user to adjust it if required.



Externally-mounted front panel

The advantages of an externally mounted front panel are that there is no longer a profile edge, and an additional installation space is created. Elements including threaded studs welded on the back of the front panel enable fixing - the same applies when the door extension is used.

Built-in components

The extruded aluminium section features all-round grooves, allowing components to be simply secured with spring nuts without the need for mechanical modification to the enclosure.



All-round mounting grooves simplify installation

OPERATING ENCLOSURE CC-3000

Frame section

External dimension	Internal dimension	Horizontal and vertical section	
120 mm	103 mm		
200 mm	183 mm		

Door section

External dimension	Internal dimension	Horizontal and vertical section	Handle section
55 mm	46 mm		

Double frames (Illustration handle sections)

External dimension	Internal dimension	Horizontal and vertical section
175 mm (120 + 55)	149 mm	
255 mm (200 + 55)	229 mm	

Horizontal and vertical section

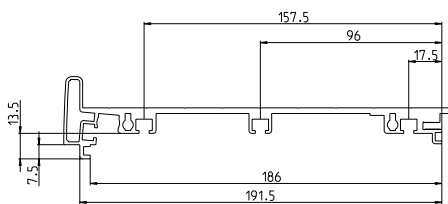
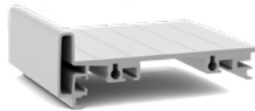
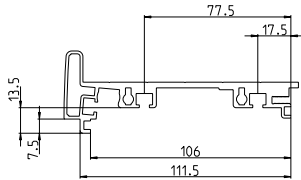

Single section configuration

	Front panel	Rear panel	Section depth	Installation depth
A	Internally mounted	Fixed or hinged	120	103
			200	183
B	Externally mounted	Fixed or hinged	120	111
			200	191



Section depth comparison: 200 mm (left) and 120 mm (right)

Configuration with combination of two sections (as door)

	Front panel	Rear panel	Section depth	Installation depth
C	Internally mounted	Internally mounted	120+55	149
			200+55	229
D	Externally mounted	Internally mounted	120+55	157
			200+55	237
E	Internally mounted	Externally mounted	120+55	157
			200+55	237
F	Externally mounted	Externally mounted	120+55	166
			200+55	246



120 mm section with additional door extension (55 mm)

ACCESSORIES OPERATING ENCLOSURE

Accessories for operating enclosure CC-3000, CC-4000, CC-4000 SL and CC-5000 *next*

BERNSTEIN not only has innovative operating enclosures in its range, but also the matching accessories. But we offer even more: If you need a product that is ready for immediate use, BERNSTEIN can also completely wire, equip etc. the enclosure tailored to your requirements.

THE RANGE OF ACCESSORIES INCLUDES THE FOLLOWING AREAS:



Connection solutions



Interface solutions



Keyboard solutions

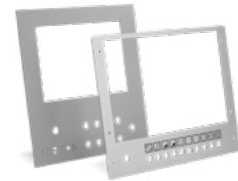

Front panel solutions



Safety solutions



Heat dissipation solutions

BERNSTEIN

Machining service



Customised wiring and the installation of components can be directly integrated in the extended enclosure production.

Starting with the pre-assembly of mounting rails and terminals, through to the assembly of cables and the complete fitting in the enclosure:
We take care of it for you thus saving you additional time and costs. BERNSTEIN is ideal as a purchasing interface for all your components.



INSTALLATION AND ASSEMBLY OF:

- Power supplies
- Operating and control elements
- Membrane keypads
- Displays, supply and data lines
- I/O modules
- Ethernet components
- SPS/IPC solutions from all well-known manufacturers

ACCESSORIES OPERATING ENCLOSURE

Keyboard / Shelf solutions

Keyboard shelf plate

- **Article number: 9806175000**
- Made of sheet steel coated similar to RAL 9006
- 495 x 255 mm
- Machining of 2 x M5 in the enclosure necessary
- Also available in stainless steel on request



Suspension system cover

Suspension system covers

- **CS-2000 SL/CS-3000/ CS-3000 neXt**
Article number: 9806495000
- **CS-2000 System 80**
Article number: 9806499000
- For closing off unneeded BERNSTEIN suspension system workings (couplings)
- Coated similar to RAL 9006
- Other RAL colours on request



Interior accessories

Spring nut set M4

- **Article number: 9806006000**
- 10 pieces in a set



Spring nut set M5

- **Article number: 9806007000**
- 10 pieces in a set

Mounting brackets

- **Article number: 9806008000**
- For fastening mounting plates or other fixtures in the enclosure
- Dimensions: 30 x 20 mm for M5 screws
- 4 pieces in a set including mounting material



Mounting rail service

- **on request**
- On request, we can cut mounting rails to length for your enclosure (TS32 / TS35 to accommodate terminal blocks). Please contact us.



Interface solutions

Interface inserts

- **Article number: 9421300000**
- 2 x USB 2.0 type A shielded



- **Article number: 9421284000**
- 2 x USB 2.0 type A with 0.7 m cable and connector

- **Article number: 9421310000**
- 1x Sub-D9 / 1xSub-D25, socket / pin



- **Article number: 9421308000**
- 1x Sub-D9 / 1xSub-D15, socket / socket

- **Article number: 9421311000**
- 1x RJ45 / USB BF-A / Sub-D9



- **Article number: 9421307000**
- Protective contact socket 250V



Interface flap

- **single Article number: 9421283000**
- **double Article number: 9421306000**
- Metal silver-coloured interface cover
- Various snap-in inserts for modular configurations
- Version in plastic, transparent
- Latching available on request
- 3 mm two-way key or rotary knob



single
66 x 120 mm



double
131 x 120 mm

RJ-45 interface

- **Article number: 9806519000**



Cable length 0.5 m

USB interface

- **Article number: 9421319000**



Cable length 1.8 m

- Interfaces with captive dust cap, protection class IP65
- Mounted in a 22.5 mm hole in the enclosure or front panel
- With connector and cable

Door arrester

- **Article number: 9806503000**

For locking the door in the open position and for limiting opening range (approx. 100°) for CC-3000 / CC-4000.

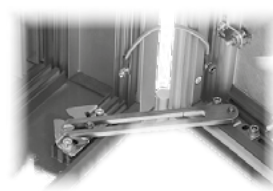

ACCESSORIES OPERATING ENCLOSURE

Machining service / special solutions

Front panel preparation service

Article number: on request

We machine aluminium front and rear panels individually to suit your specific requirements. Engraving or various printing processes also possible on request. Simply provide us with a drawing with your requirements.

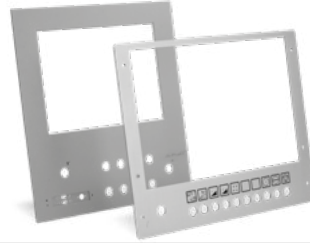

Crystal clear makrolon front cover

Article number: on request

Please contact us regarding protection for a commercially available monitor that is secured in the enclosure by means of a TFT monitor mounting bracket.



TFT monitor mounting bracket

Article number: 9806679000

Commercially available displays can be easily secured in modern operating enclosures, thus encapsulating them in a way that meets industrial standards.

For display, pivotable with Vesa adapters 75 or 100 (15" to 20").



Heat dissipation solutions

Fan mounting bracket set

- **Article number: 9806491000**
- Set of 2 brackets for axial or radial fan
- RAL 7035



Filter fan set PF1000

- **Article number: 9806492000**
- 230 V filter fan + outlet filter 24 m³/h, IP54
- Dimension: 109 x 109 x 49/19 mm
- 1 pc per unit
- 12 V / 24 V / 48 V on request



Keyboard drawer for control panels

Instantly-ready for use with just one swift movement – our new keyboard console with ergonomic flexibility is suitable for many control panels such as the BERNSTEIN CC-3000, CC-4000 or CC-5000 neXt. There are numerous arguments for using our new keyboard drawer as illustrated below.



Keyboard drawer pulled out

- Ergonomically adjustable (20°) keyboard shelf

Product features

- Protection degree IP65 in closed condition
- External dimensions, without handle: 482.5 × 101 × 157 mm (W × D × H)
- Keyboard shelf can incline by 20° – lock prevents unintentional folding in
- Storage area for keyboard: 373 × 142 × 17 mm (W × D × H)
- Drawer enclosure with screwed enclosure cover
- Lean handle bar for secure opening and closing without tilting
- Safe locking in open condition to prevent unintentional closing
- Mechanical snapper for the secure closure
- Drawer lockable with customary sash locks, e.g. double-bit, 3-kt. / 4-kt. etc. available as an option
- Cable leadthroughs on the underside and back side of the drawer enclosure



Keyboard drawer closed

- Lockable against unauthorised access



Keyboard drawer pulled out

- Lock prevents unintentional closing

CS-4000_{neXt} – Industrial operator station Console or column variant

Unlike standard suspension system solutions with individual screens or IPCs, the CS-4000 neXt meets the requirements of the Machinery Directive because of the possibility of integrating emergency stop devices. Due to its two-chamber design and clever construction, an IP65 solution can be achieved.

Product features

- High protection class IP65 at area of closed column chamber
- Internal cable routing
- IPC and keyboard shelf holder can be positioned individually
- IPC holder with graduated tilt control
- Optional integrated control elements (to fulfil the Machine Directive 2006/42/EG)
- Column of high-quality extruded aluminium sections (naturally anodised, 2-chamber column)
- Customer-specific length of the column possible

Scopes of application

- Production lines in the automotive industry
- Plant and machine construction with decentralised controlling concept
- Decentralised display or HMI positioning



- 1 Column
- 2 Slider or mounting element
- 3 IPC with holder: Mounting height variable, graduated tilt control
- 4 Push button cover for control elements
- 5 Keyboard shelf (pull-out mousepad is optional)
- 6 Cable conduit cover (access through open column chamber)
- 7 Base plate – fixed or rotatable

Application examples



Suspension system CS-4000^{next}
Console variant: connection from below

- IPC with controls
- Keyboard shelf
- Column
- Rotatable stand base

Suspension system CS-4000^{next}
Column

- IPCs
- Keyboard shelf with adjustable keyboard holder supplemented by:
- Control console
- Pedestal
- Fixed stand base



Suspension system CS-4000^{next}
Column

- Keyboard shelf with adjustable keyboard holder (short holder not possible!) supplemented by:
- Control console
- Pedestal
- Rotatable stand base
- Box PC holder for IPC



Suspension system CS-4000^{next}
Column

- Signal lamp
- Shelf for industrial tablet
- Connection from below
- Push-button panel for operating elements
- Pedestal
- Fixed stand base



The compact console version

Fixed or tiltable



Fixed tilt angle

- Fixed tilt angle of 35°
- Suitable for VESA 75/100, 48 mm round tube (customer specific attachment on request)



Tilt adapter flex for console column

- For the adjustment of the IPC tilt angle for console configurations
- Inclines in 5° steps, adjustable from 0° to 60°
- Star grip for locking the selected position
- Suitable for VESA 75/100, 48 mm round tube (customer specific attachment on request)
- Optional gaiter for IPC with open connection area

Ergonomic measurements according to DIN 33402-2

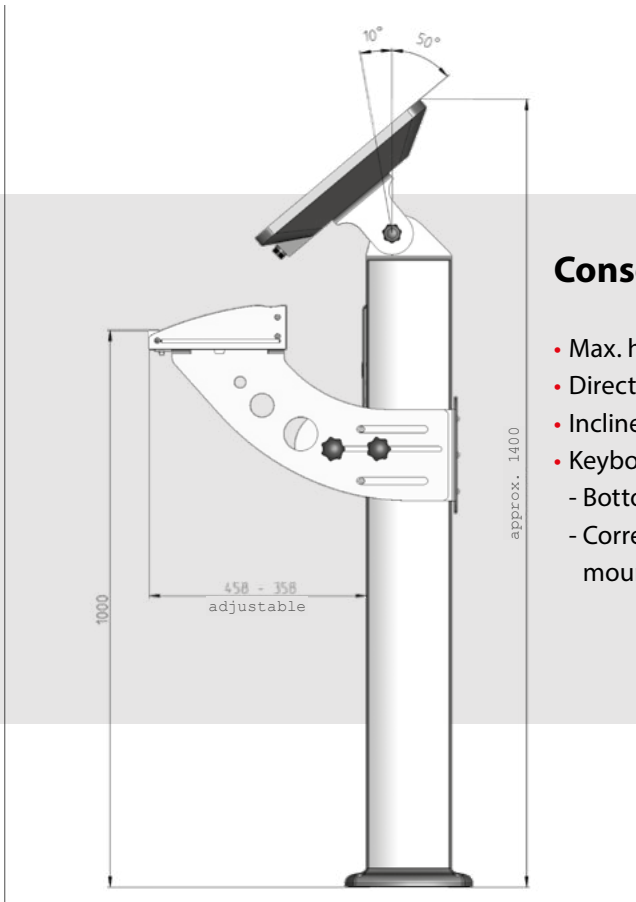

Console version

- Max. height 1350 mm for 35°
- Direct assembly of the IPC on tilt adapter
- Inclines in 5° steps, adjustable from 0° to 60°
- Keyboard height (standard value 1,000–1,100 mm)
 - Bottom edge of keyboard 950–1,100 mm
 - Corresponding fixing position of the mounting element/slider

Column version

- Visualisation height (standard value 1,650 mm)
 - Centre of the screen 1,650 ± 50 mm
 - Corresponding fixing position of the mounting element/slider
- Desk area height (standard value 1,000 – 1,100 mm)
 - Lower edge of the keyboard 950 – 1,100 mm
 - Corresponding fixing position of the mounting element/slider

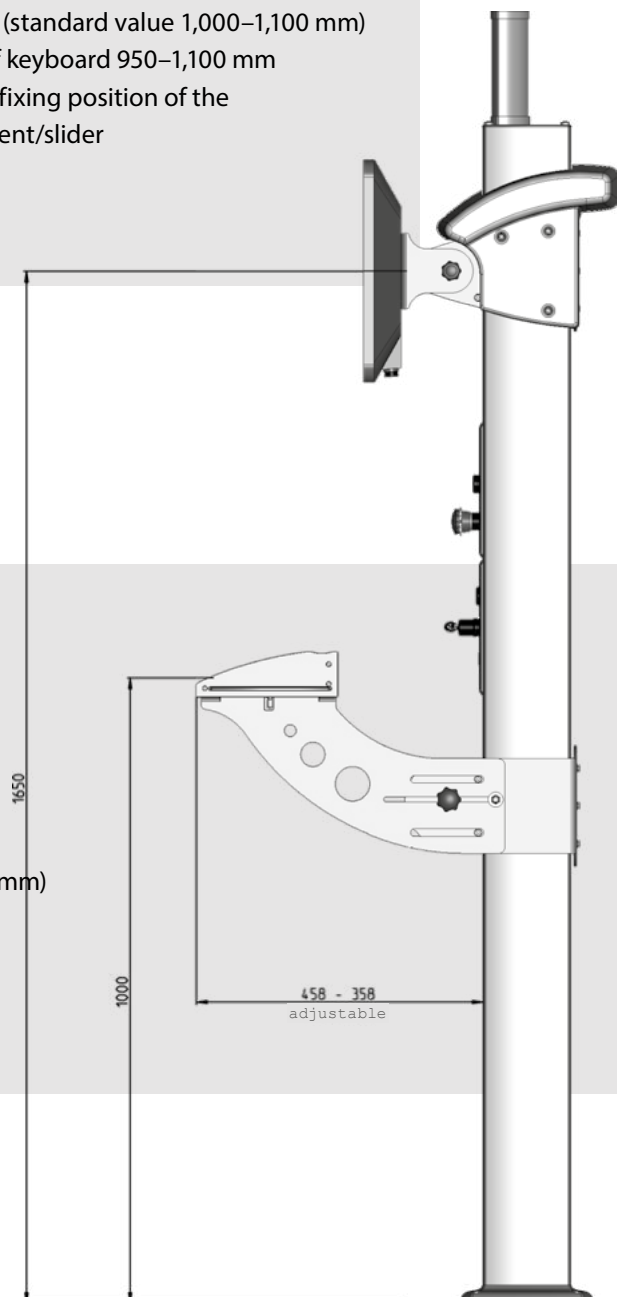

Base plate

Fixed and rotatable

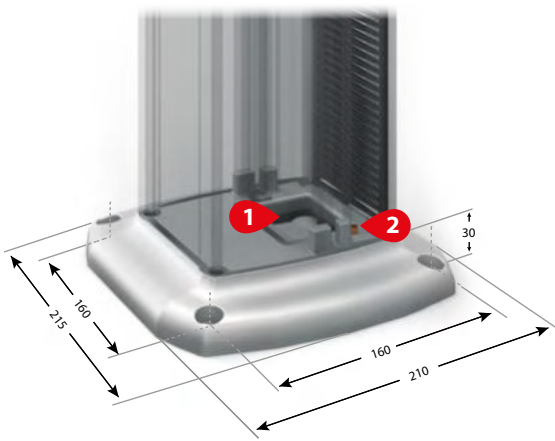

Fixed base plate

- Cable entry into the open column chamber ①
- Connection for potential equalisation ②
- Optionally supplied with levelling adjustment screws

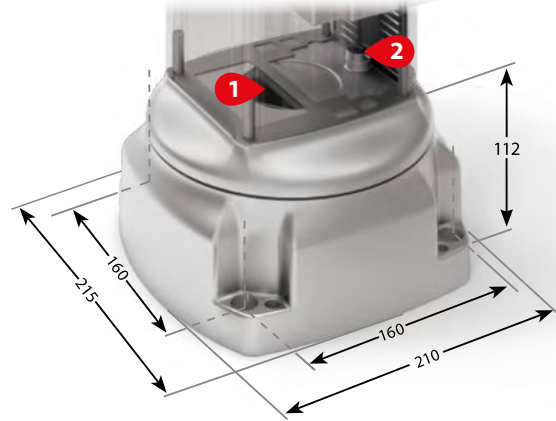

Rotatable base

- Angle of rotation 300° with limit stop
- Protection class IP65
- Installation area for mounting the cable entry system (e.g. Icotek KEL, Contaclip KDSClick) for cable entry into the closed column chamber ①
- Connection for potential equalisation ②
- Optionally supplied with levelling adjustment screws

Aluminium column with double chamber system

- Closed column chamber ① (IP65)
- Open column chamber ② for IPC and keyboard shelf holder positioning and cable routing
- Cable routing via open column chamber
- Open column chamber (back side) optically closed through brush strip

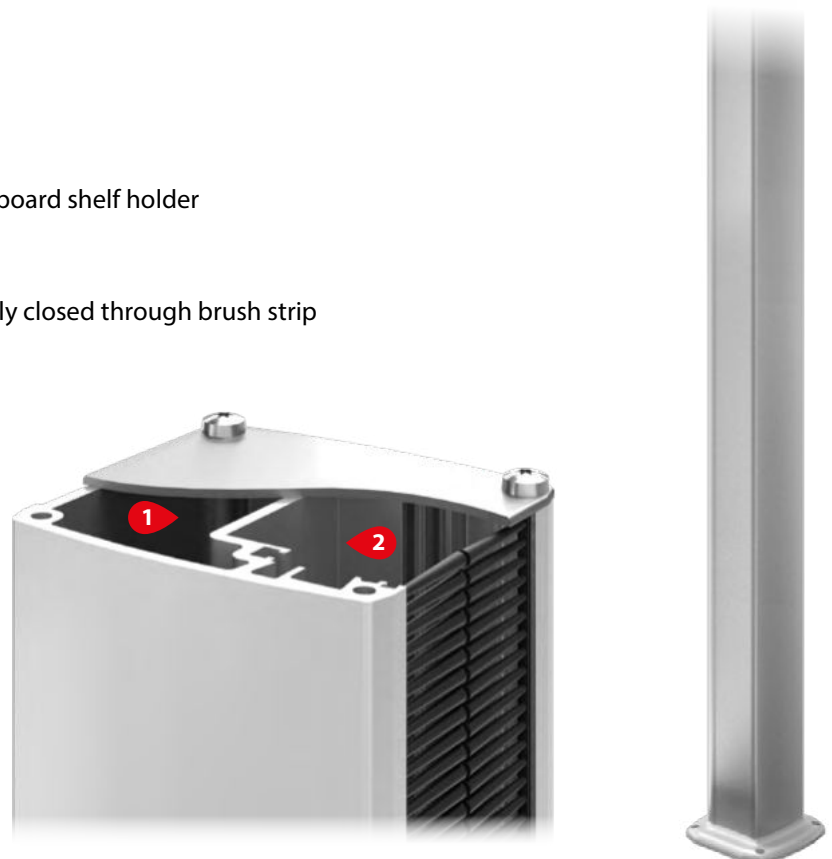
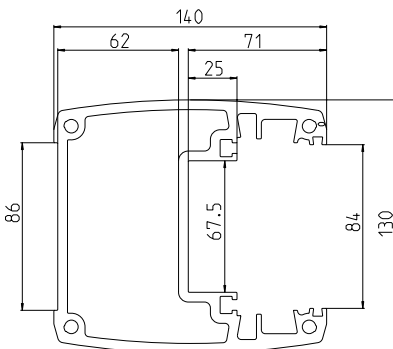

Slider

Individual height adjustment

Product features

- Height adjustable without tools
- Simple fixing of the adjusted position through star grip
- Linear guide with sliding elements
- Limit stops for constraining and securing adjustment travel

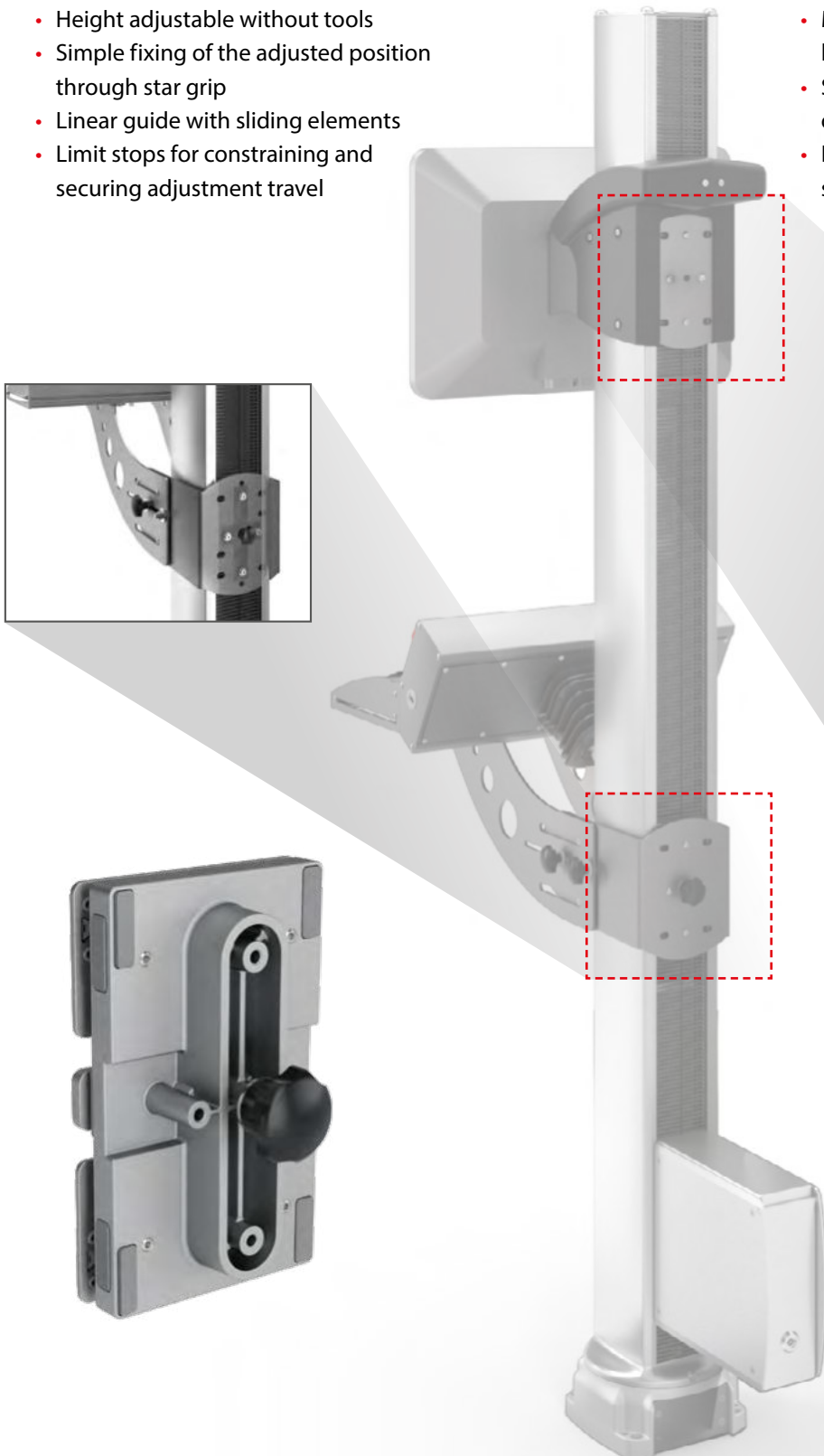

Mounting element

for a fixed height

Product features

- Mounting element for IPC and keyboard shelf holder positioning
- Subsequent change of position only by use of a tool
- Limit stops for constraining and securing adjustment travel

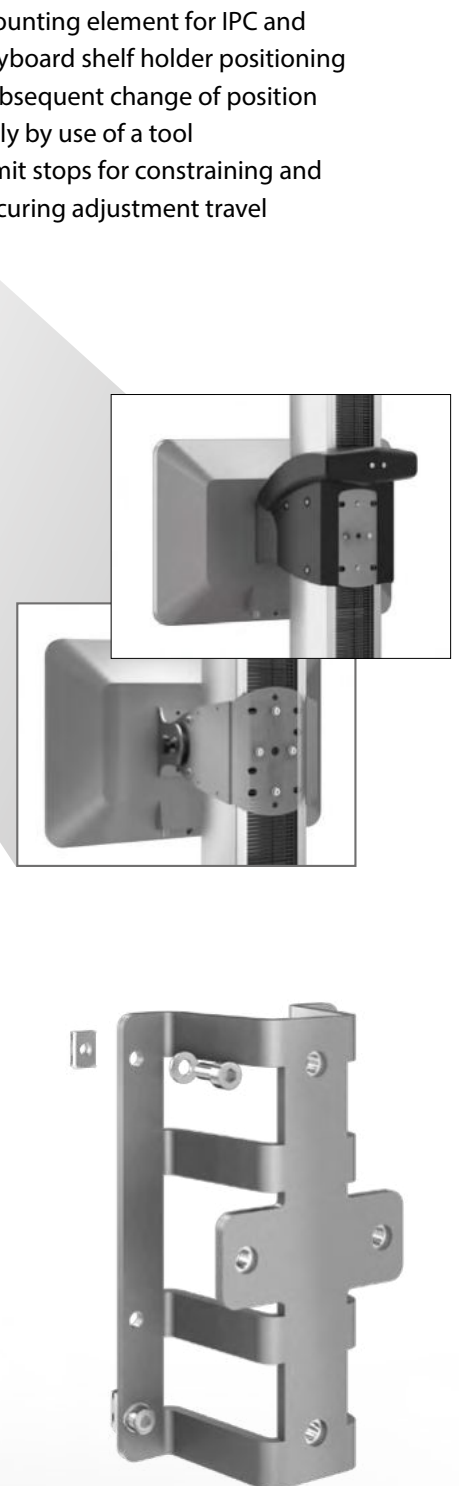

SUSPENSION SYSTEM CS-4000 next

IPC holder

Variable height and tilt adjustment

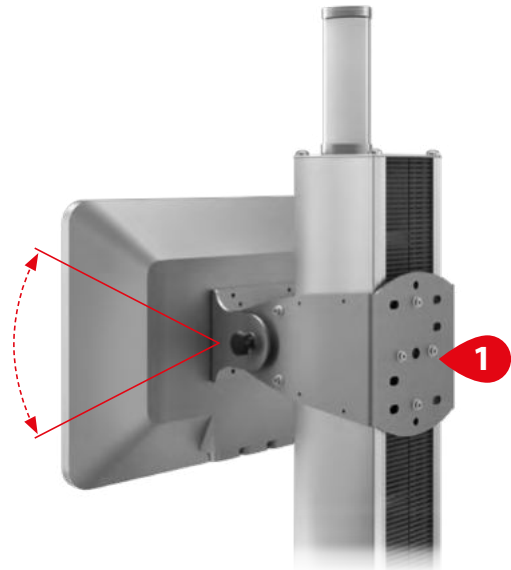
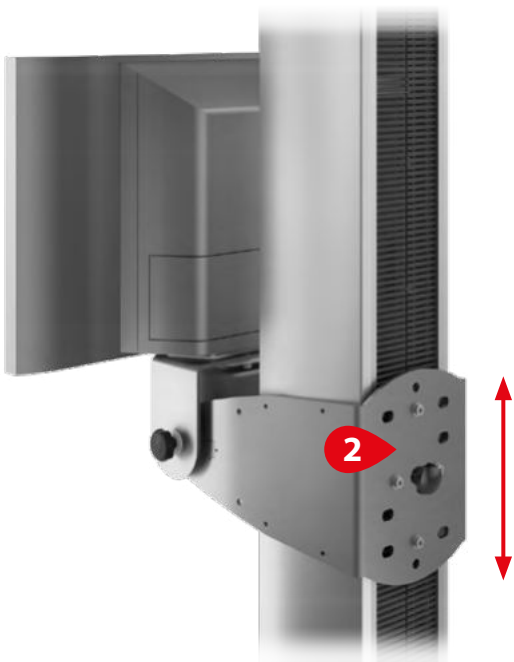

- Height variable through mounting element **1** (tool-bound) or slider **2** (without tools) freely selectable
- Connection of IPC/display/monitor with VESA 75/100 or Ø 48 round tube
- Maximum inclination: $\pm 24^\circ$ (depending on connection type)

Possible connection type

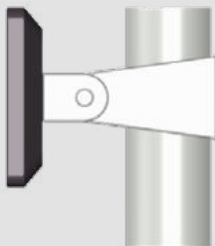

VESA 75/100
Connection from behind



Siemens Pro
Connection from below

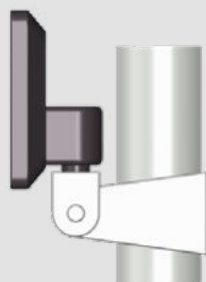

Round tube Ø 48 mm
Connection from below

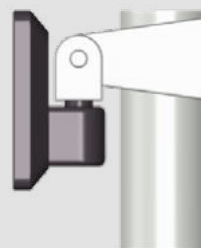

Round tube Ø 48 mm
Connection from above

Keyboard shelf – Choice of two versions

Fixed keyboard shelf

- Height variable through mounting element / slider
- Extruded aluminium sections (naturally anodised)
- Optional mousepad pulled out to the right or left hand side ①
- Fastening option in the back cover ③

Adjustable keyboard shelf

- Height variable through mounting element/ slider
- Extruded aluminium sections (naturally anodised)
- Optional mousepad pulled out to the right or left hand side ①
- Maximum possible depth adjustment 100 mm ②
- Fastening option in the back cover ③

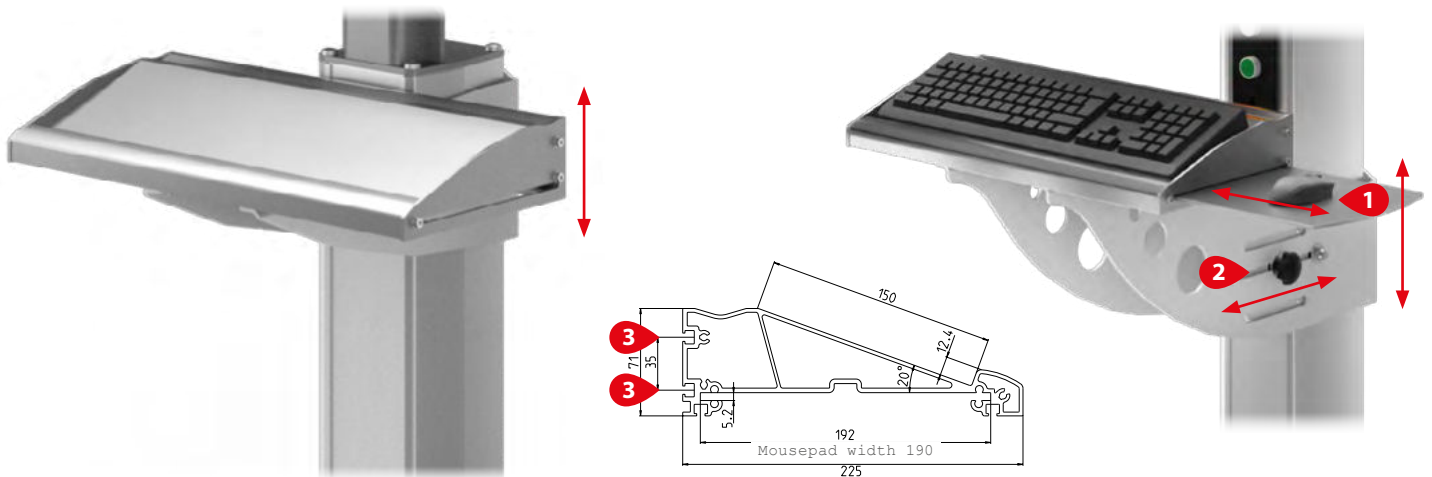

Control console – Integration of all necessary command modules and signal units

The emergency stop function is still fully guaranteed in the event of a replacement IPC being required.

For the installation of ...

- Command and signalling devices such as push buttons, emergency stop buttons, etc.
- Main switches, key switches
- *Electronic Key System (EKS)* – Transponder-based read/write stations
- Adaptable in width individually
- Extruded aluminium sections (naturally anodised)
- Adaptation to keyboard shelf
- Screw-fixed rear panel

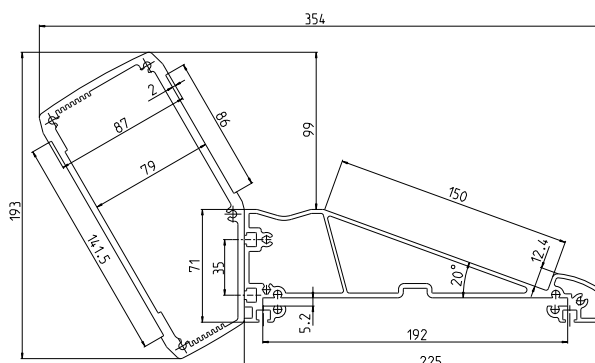

Covers and inspection window with various equipment variants

Push button cover

- Cover for control elements
- Emergency stop and key switch can be integrated
- Maximum of 5 push buttons or 3 push buttons with identification label
- Installation from the front
- IP65 due to foamed sealing
- Installation area 165 × 60 mm

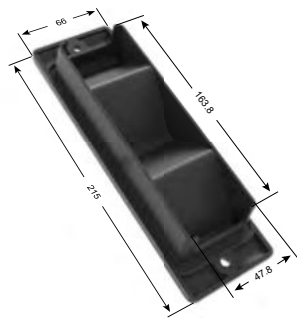
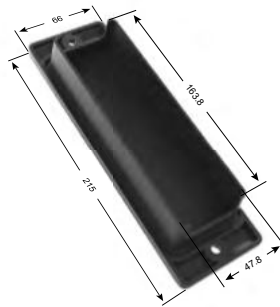

Cable conduit cover

- Cable conduit cover with 45-degree bevelled curve for optimum bending radius
- Cable entry into the closed column chamber **1**
- IP65 due to foamed sealing
- Maximum installation area 2 × M25

Inspection window cover

- For monitoring and control of signalling and built-in devices such as the MURR compact module
- Aluminium cover with acrylic glass cover
- Compatible with CS-4000neXt column section
- Adaptable to AIDA mixing module



Aluminium cover

- Main switches
- Machine operator identification systems
- Key Panels

Accessories



Universal tray

- Safe storage area for printers, PC hardware or similar periphery units
- Fixes to the assembling element or slider on the back side of the column
- Individual mounting on the left, right, or even on both sides
- Storage area 450 × 300 mm (adjustable according to your wish)

Box PC holder

- For safe storage of customary box PCs
- Front side with opening flap – lockable with customary sash locks, e.g. two-way bit
- Protection degree IP65
- Cable entry via closed column chamber
- Inside dimensions (LxWxH): 210 × 60 × 215 mm

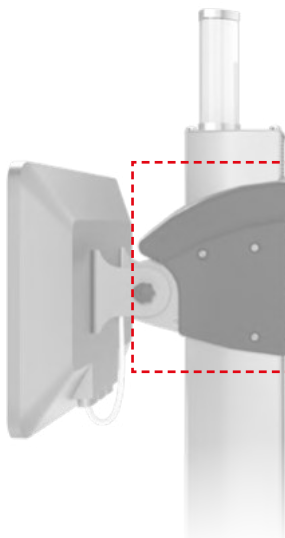

Cable channel

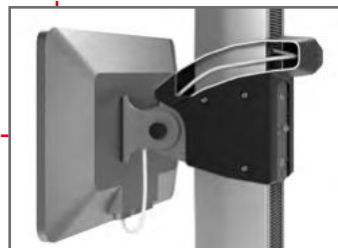

Gaiter channel



Signal lamp cover



Aluminium suspension system CS-3000 *neXt*

The CS 3000 neXt is characterised by high functionality and an attractive design. The system as a supplement to the CS-3000 series, the system benefits from the simplest installation and has special features such as smooth transitions from the tube to the component, high ease of cleaning, and the usual high BERNSTEIN quality. The wide variety of components paired with high stability and load capacity create the prerequisites for individual solutions.

Product features

- Suspension system for loads up to 80 kg (with 1 m outrigger length)
- Individual configurability
- Can be combined with CS-3000 + CS-480 B.fleX suspension systems
- Wide range of connections due to large portfolio of components

Load diagram CS-3000 *neXt* for static load

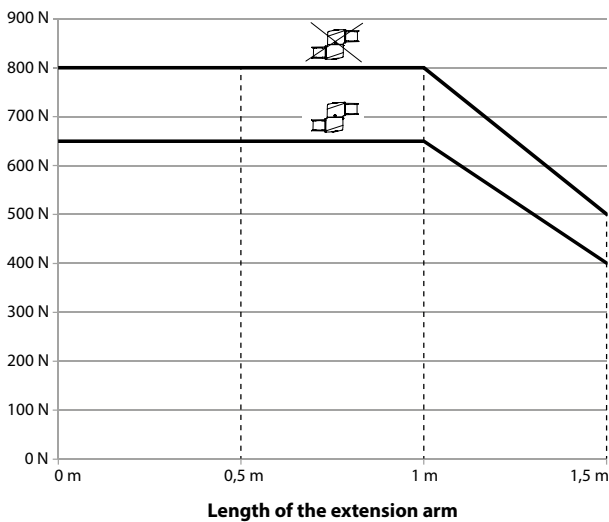

Application examples



CS-3000_{neXt} suspension system from above

- CS-3000 next Wall joint
- CS-3000 next Elbow
- CS-3000 next Coupling
- CC-5000 next Enclosure



CS-3000_{neXt} suspension system with turn/tilt coupling

- Turn/tilt coupling with IPC
- Rotation angle: 300° with stop, can be limited by optional rotation angle segments
- Tilt angle with adjustable stop: +/-105°
- Screwed mounting opening, suitable for feed-through of DVI connectors



CS-3000_{neXt} suspension system with rotating wall joint

- CS-3000 neXt Wall joint rotatable
- CS-3000 neXt 250 mm tube
- Panel coupling with VESA connection on CC-5000 neXt



CS-3000_{neXt} suspension system with turn/tilt coupling

- Turn/tilt coupling with IPC
- Rotation angle: 300° with stop, can be limited by optional rotation angle segments
- Tilt angle with adjustable stop: +/-105°
- Screwed mounting opening, suitable for feed-through of DVI connectors

SUSPENSION SYSTEM CS-3000 next

Materials

- Anodised aluminium profiles
- Components: Aluminium die cast
- Aluminium covers on installation openings
- Bearings: POM
- Seals: Neoprene

Colours

- Components: white aluminium (RAL 9006) or anthracite grey (RAL 7016)
- Tubes: Aluminium, naturally anodised
- Components and tubes can all be optionally powder-coated to a wide variety of RAL colours



Application examples of the CS-3000 neXt suspension system
Wide range of configuration options

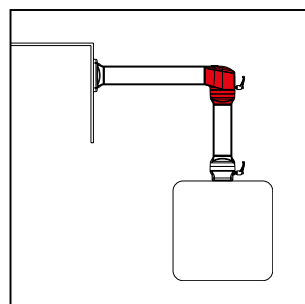
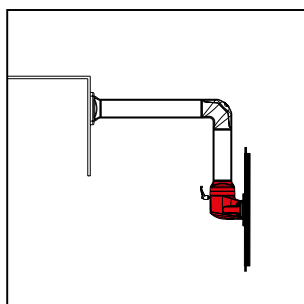
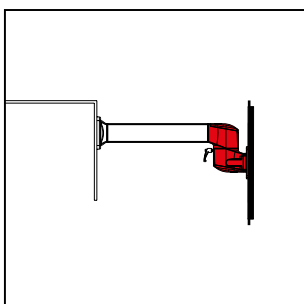
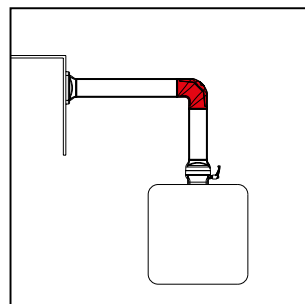
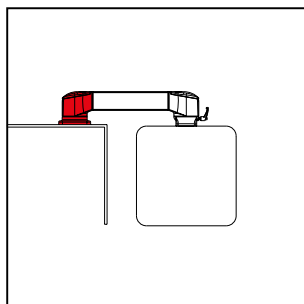
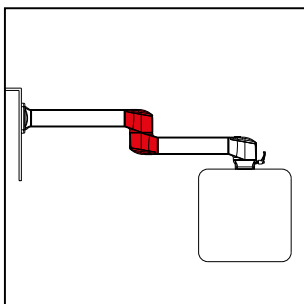
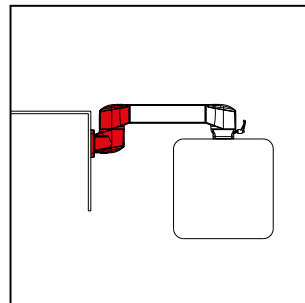
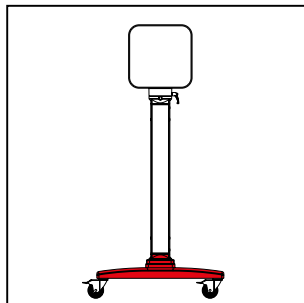
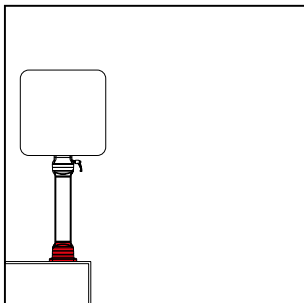
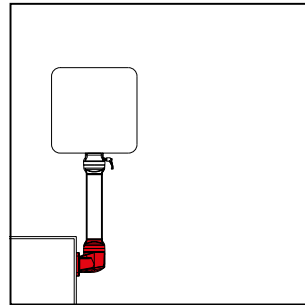
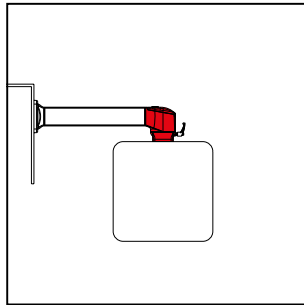
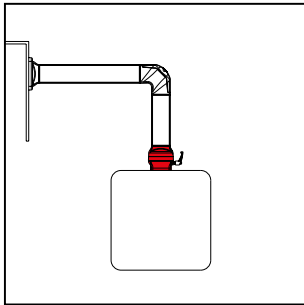

Highlights



Reducing elbow

- A combination of the CS-3000 with the light-duty suspension system CS-3000 neXt
- Areas of use:
 - Higher loads / extension of the arm lengths by using CS-3000 in the horizontal plane
 - For the connection of flat enclosures with narrow components and tubes by using CS-3000 neXt in the vertical plane



Turn/tilt coupling

- Allows the connection of panels / displays or IPC from above or below
- Angle of rotation 300° with stop, limitable by optional rotation angle segments
- Tilt angle with adjustable stop: +/-105°
- Screw-fixed installation opening, suitable for DVI connectors
- With an additional adapter plate for rear connection of panels / displays or IPC with fixed rear panels



Panel coupling

- For a connection at the rear of displays / monitors with VESA
- For the connection of flat operating enclosures via the rear panel
- VESA flange size, hole pattern 75 and 100
- Suspension system attachment in vertical and horizontal version possible
- Individual colour combination of all components in accordance with RAL colours

Assembly

- Short assembly times and therefore extensive cost savings:
 - Slide the tube onto the component
 - Press down slightly
 - Tighten screws
- Cable and installation openings at all joints in the system
- Use of a DVI connector is possible

Function

- Turning range of the rotary components: 300°
- Regulation of the rotation angle via swivel angle limiter

Tubes

- Standard lengths of 250 mm up to 1500 mm in 250 mm steps
- Machined tubes in special lengths





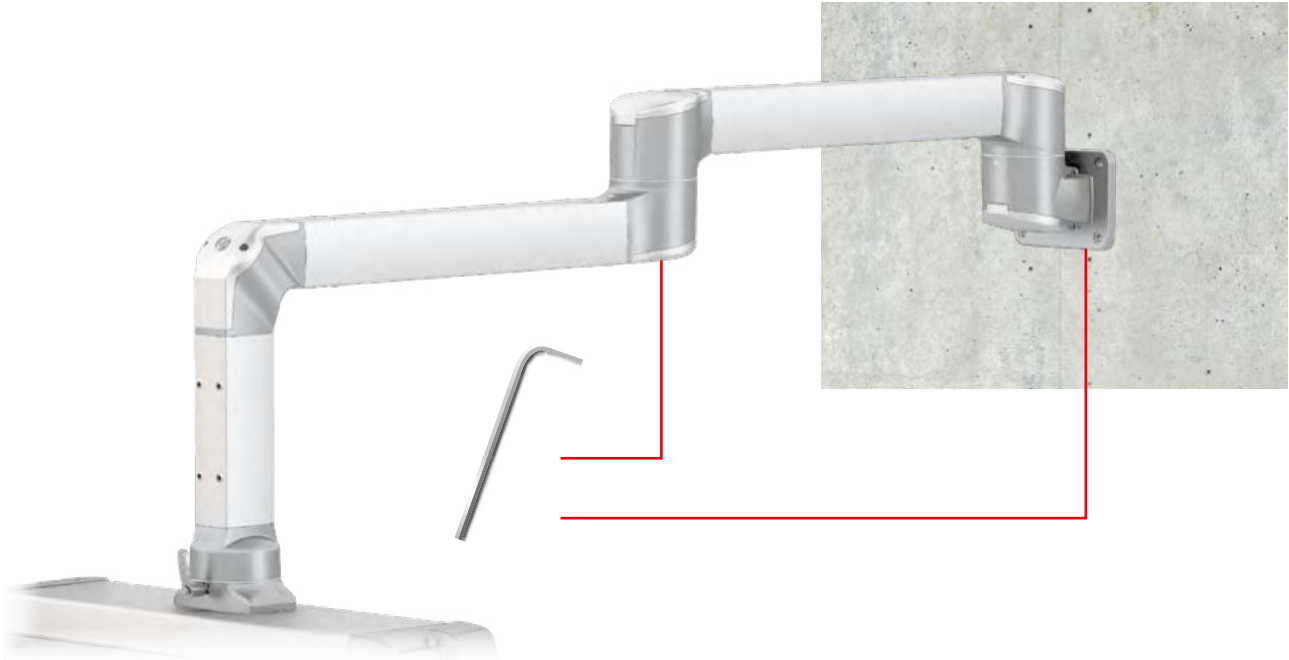

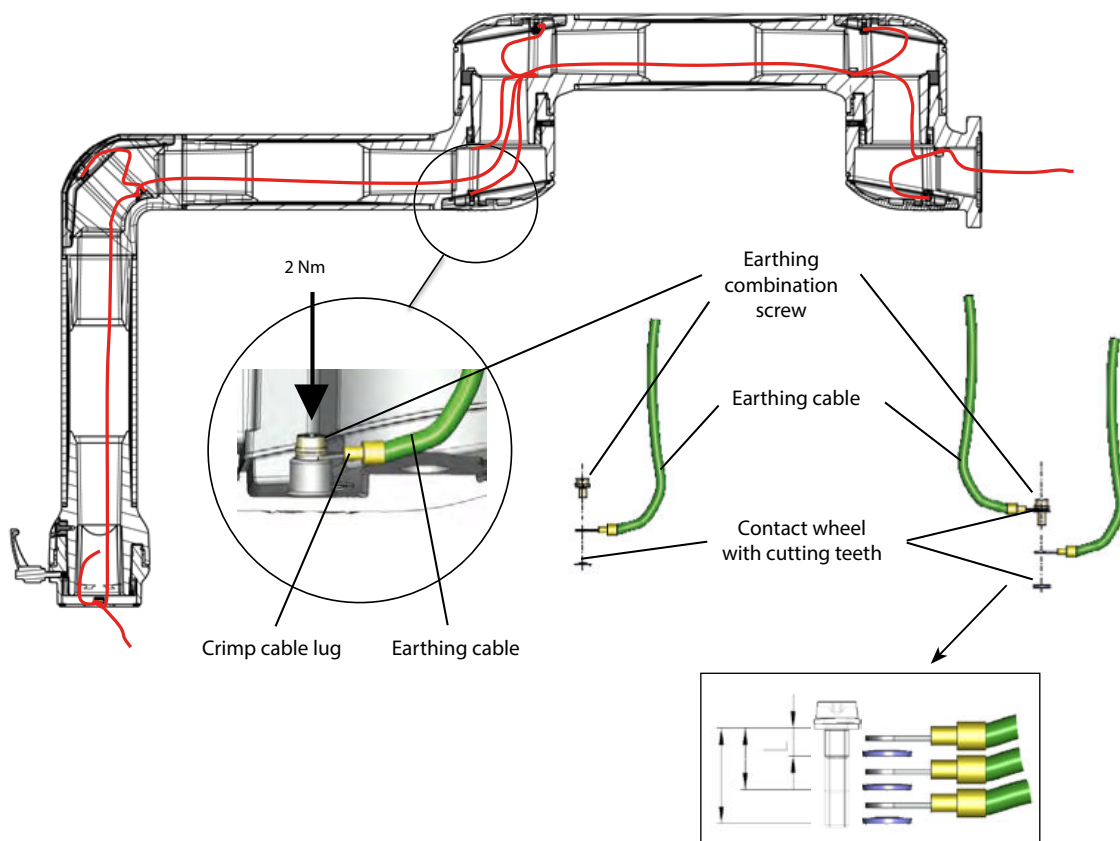

One-man assembly

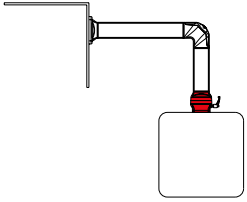
Quickly and safely mounted

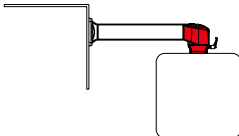

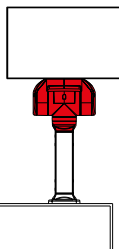
Earthing example

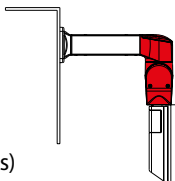

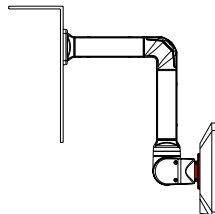
	Article	Application example
	<p>Straight coupling 1017300002 RAL 9006 white aluminium</p> <ul style="list-style-type: none"> • Angle of rotation 300° with stop • Weight: 1630 g <p>(An adapter (narrow enclosures) is required for attachment to enclosures < 83 mm)</p>	
	<p>Elbow coupling 1017300003 RAL 9006 white aluminium</p> <ul style="list-style-type: none"> • Angle of rotation 300° with stop • Screw-fit installation opening • Weight: 2070 g 	
	<p>Turn/tilt coupling S 1017300072 RAL 9006 white aluminium (tilt moment 56 Nm) 1017300078 RAL 9006 white aluminium for panel (reduced tilt moment 27 Nm)</p> <ul style="list-style-type: none"> • For connecting panels / displays / IPC with screw-fixed rear panel, the fixing hole pattern is flexible • Angle of rotation 300° with stop • Tilt angle with adjustable stop: +/-105° (without attachments) • Screw-fixed installation opening, suitable for DVI connectors • Weight: 4600 g 	
	<p>Turn/tilt coupling W 1017300070 RAL 9006 white aluminium (tilt moment 56 Nm) 1017300076 RAL 9006 white aluminium for panel (reduced tilt moment 27 Nm)</p> <ul style="list-style-type: none"> • For connecting panels / displays / IPC with screw-fixed rear panel, the fixing hole pattern is flexible • Angle of rotation 300° with stop • Tilt angle with adjustable stop: +/-105° (without attachments) • Screw-fixed installation opening, suitable for DVI connectors • Weight: 5100 g 	
	<p>Adapter plate VESA 75/100 9806000044 RAL 9006 white aluminium</p> <ul style="list-style-type: none"> • All that is needed (in addition for the turn/tilt coupling) to connect panels / displays / IPC to the rear side with the VESA 75/100 hole pattern • Weight: 300 g 	



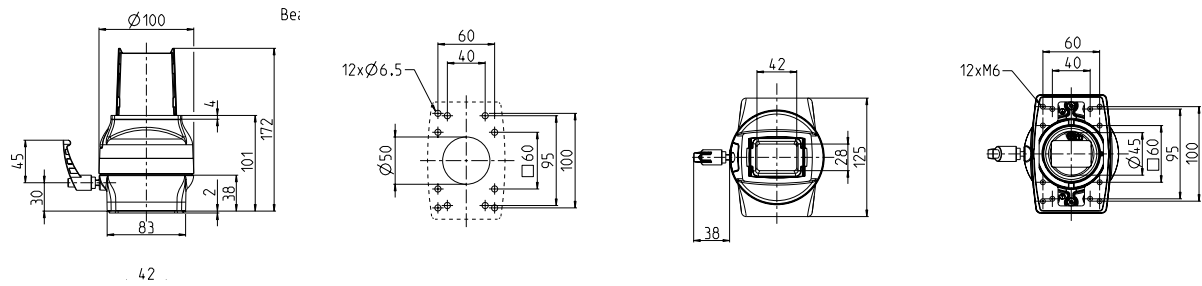

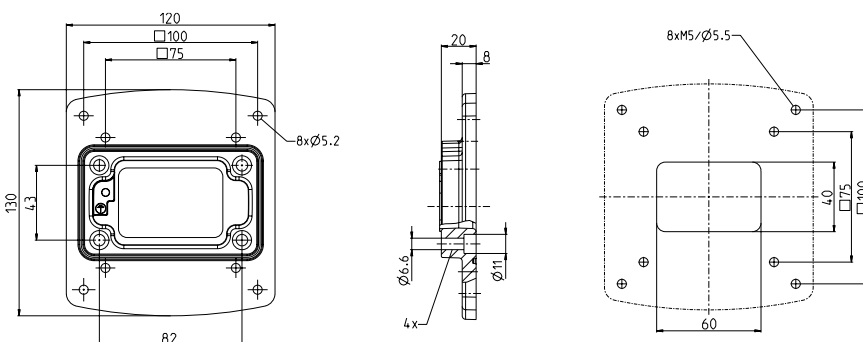
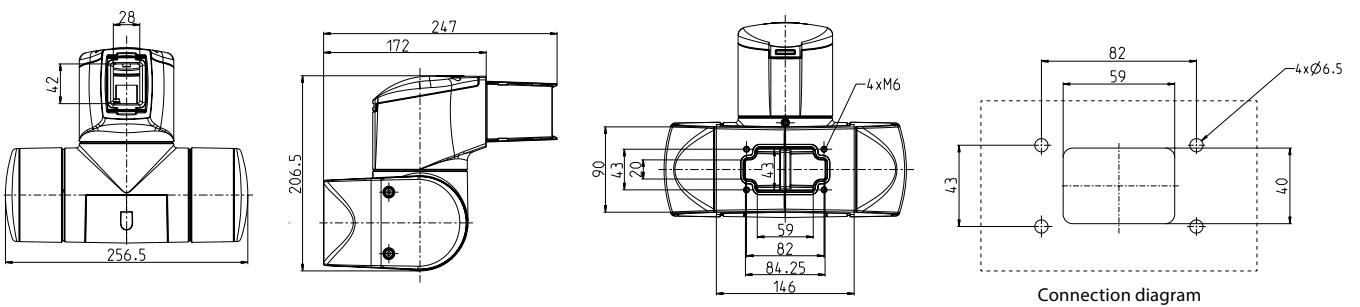
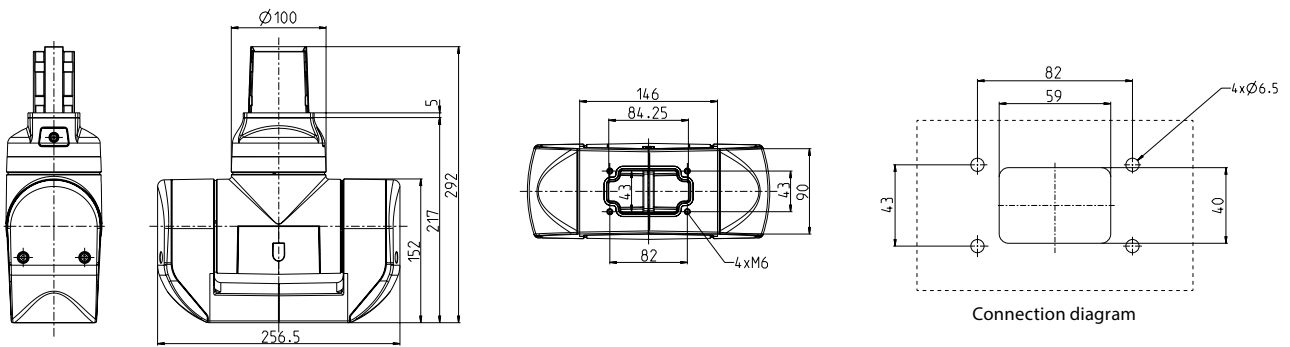
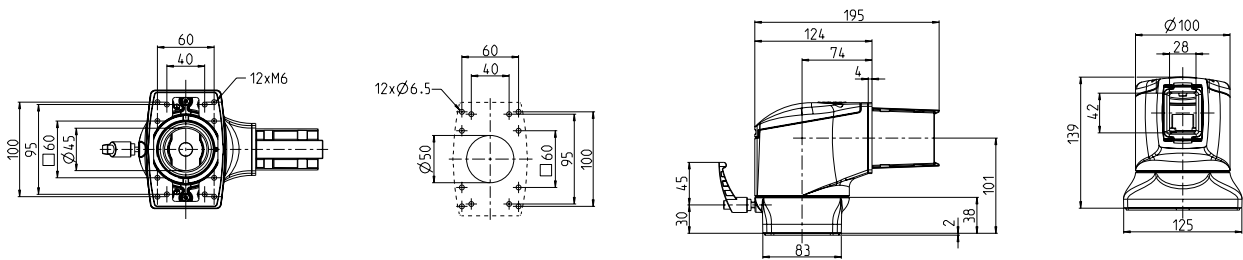

Dimensions in mm

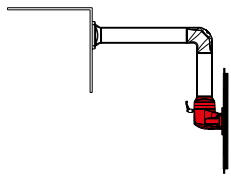
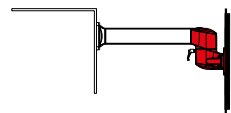

42

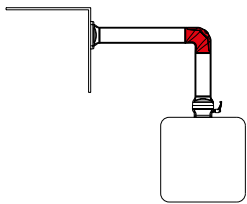

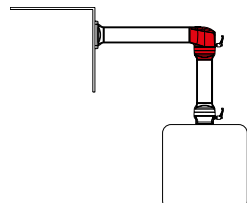

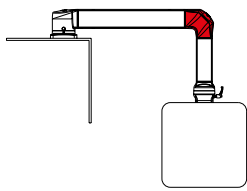



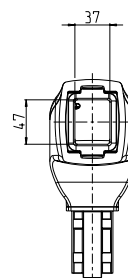
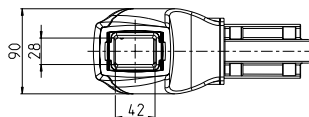
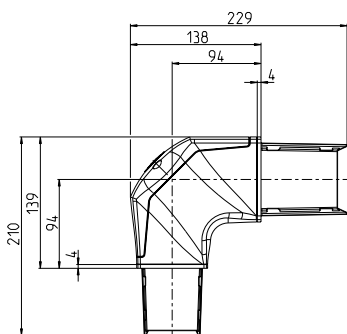
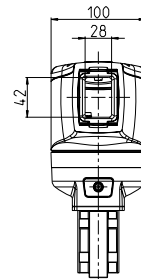
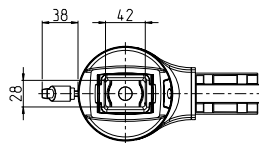
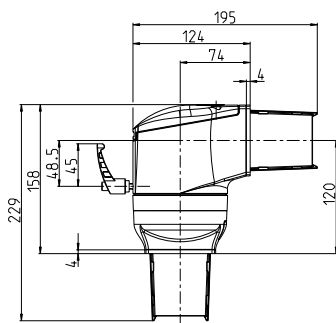
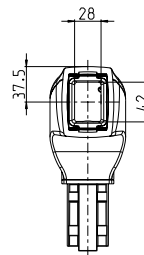
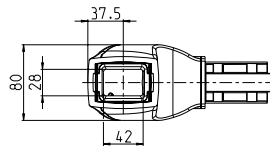
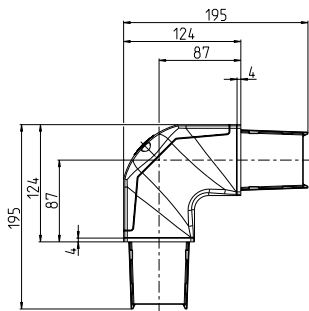
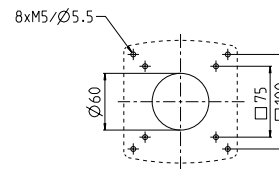
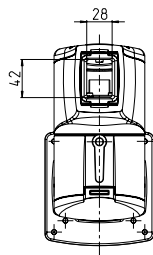
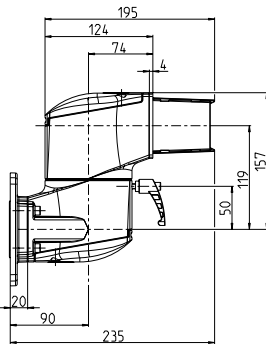
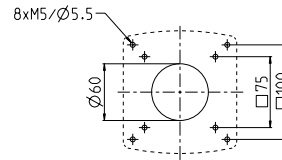
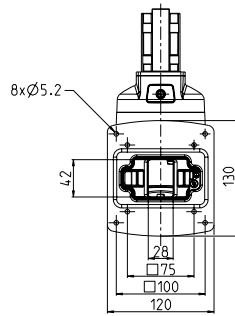
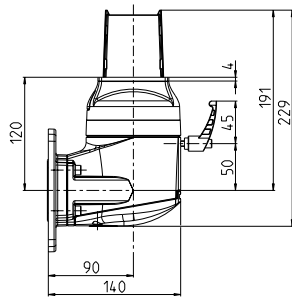

SUSPENSION SYSTEM CS-3000 neXt

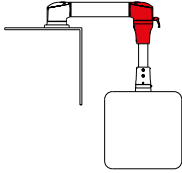
	Article	Application example
	<p>Panel coupling S 1017300004 RAL 9006 white aluminium</p> <ul style="list-style-type: none"> • For attachments to the rear of panels / displays or operating enclosures with a screw-fit rear panel • Standard hole pattern VESA 75/100 • Angle of rotation 300° with stop • Screw-fit installation opening • Weight: 2530 g 	
	<p>Panel coupling W 1017300005 RAL 9006 white aluminium</p> <ul style="list-style-type: none"> • For attachments to the rear of panels / displays or operating enclosures with a screw-fit rear panel • Standard hole pattern VESA 75/100 • Angle of rotation 300° with stop • Screw-fit installation opening • Weight: 2970 g 	
	<p>Elbow 1017300007 RAL 9006 white aluminium</p> <ul style="list-style-type: none"> • Screw-fit installation opening • Weight: 1250 g 	
	<p>Elbow, rotary 1017300008 RAL 9006 white aluminium</p> <ul style="list-style-type: none"> • Angle of rotation 300° with stop • Screw-fit installation opening • Weight: 2320 g 	
	<p>Reducing elbow 1017300009 RAL 9006 white aluminium</p> <ul style="list-style-type: none"> • Elbow coupling for the combination of CS-3000 neXt and CS-3000 suspension systems • Screw-fit installation opening • Weight: 1770 g 	

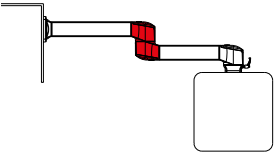
Dimensions in mm

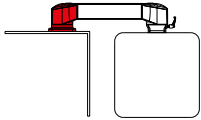

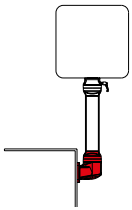
SUSPENSION SYSTEM CS-3000 next

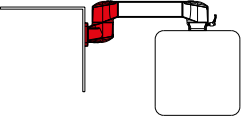
	Article	Application example
	<p>Elbow, rotary (extension CS-480 B.flex) 1014800008 RAL 9006 white aluminium</p> <ul style="list-style-type: none"> • Aluminium die-casting • Angle of rotation 300° with stop • Weight: 2457 g • Connection for equipotential bonding 	
	<p>Intermediate joint 1017300010 RAL 9006 white aluminium</p> <ul style="list-style-type: none"> • Angle of rotation 300° with stop • 2 screw-fit installation openings • Weight: 2740 g 	
	<p>Top joint 1017300014 RAL 9006 white aluminium</p> <ul style="list-style-type: none"> • Angle of rotation 300° with stop • Screw-fit installation opening • Weight: 2200 g 	
	<p>Wall joint S 1017300011 RAL 9006 white aluminium</p> <ul style="list-style-type: none"> • Angle of rotation 300° with stop • Screw-fit installation opening • Weight: 2490 g 	
	<p>Wall joint W 1017300012 RAL 9006 white aluminium</p> <ul style="list-style-type: none"> • Angle of rotation 300° with stop • 2 screw-fit installation openings • Weight: 2930 g 	

Dimensions in mm

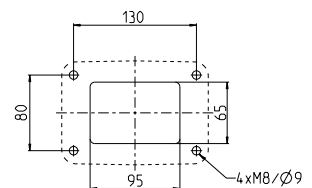
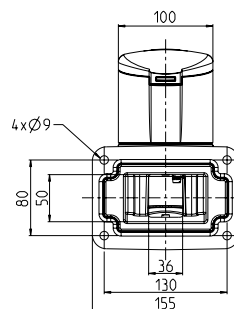
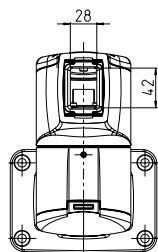
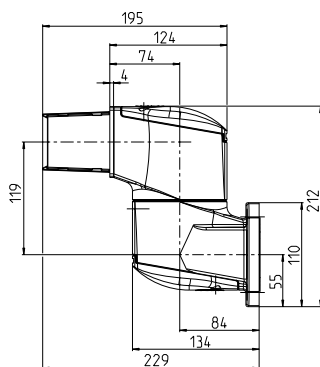
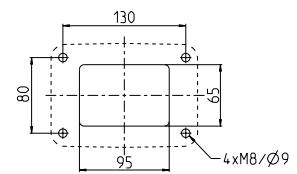
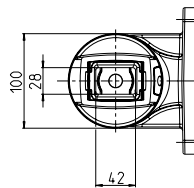
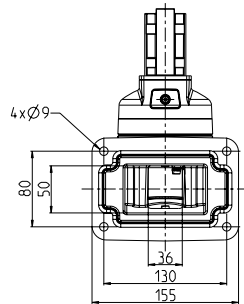
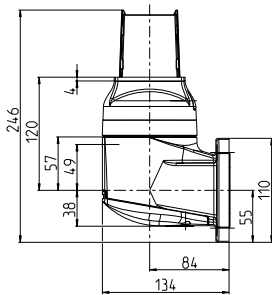
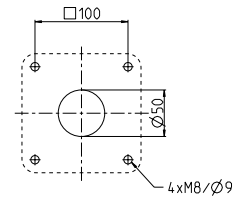
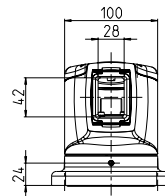
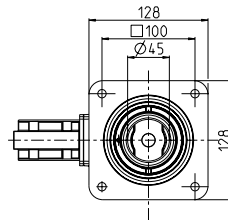
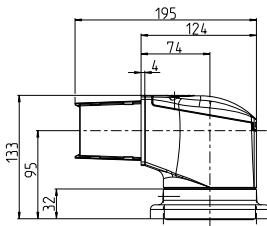
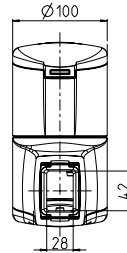
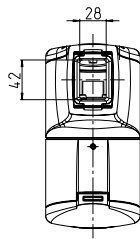
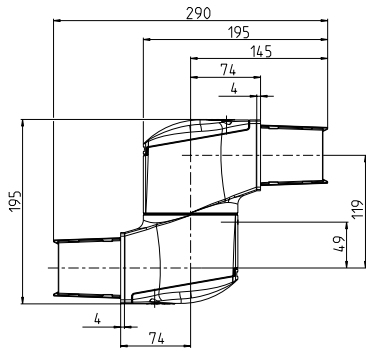
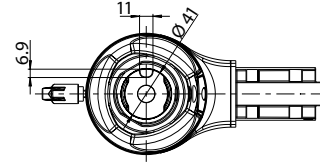
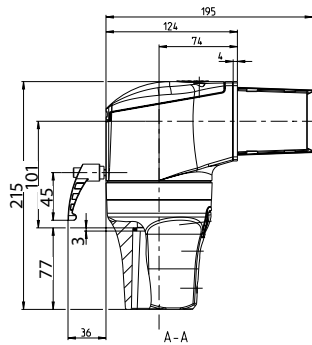
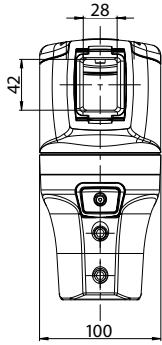

SUSPENSION SYSTEM CS-3000 next

	Article	Application example
--	---------	---------------------



Base / wall flange

1017300015 RAL 9006 white aluminium
 • Weight: 830 g

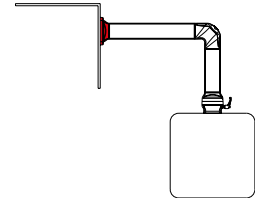

Base, rotary

1017300013 RAL 9006 white aluminium
 • Angle of rotation 300° with stop
 • Weight: 1770 g

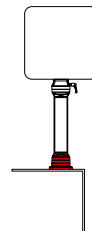

Adapter (narrow enclosures)

1017300001 RAL 9006 white aluminium
 • Only to be used together with couplings
 • For attachment to narrow enclosures with depths < 83 mm
 • Weight: 300 g

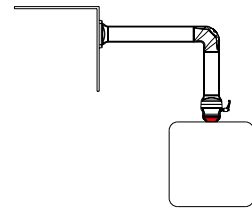

Tube profiles

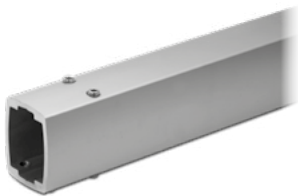

Standard lengths (available from stock)	Article number	Weights in kg
Tube cross-sections x Length		
55 x 75 x 250 mm	9524700001	0.90
55 x 75 x 500 mm	9524700002	1.70
55 x 75 x 750 mm	9524700003	2.60
55 x 75 x 1000 mm	9524700004	3.40
55 x 75 x 1250 mm	9524700005	4.30
55 x 75 x 1500 mm	9524700006	5.20

Drilling label for special tube lengths

9012328000

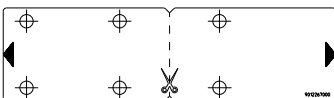

Using the template, bore the holes in the exact positions. Choose the appropriate connection section and order the number of drilling templates required.



Drilling jigs for special tube lengths

9806936000 Set 3-piece

Once the tube has been cut to its desired length, drilling jigs can be fitted. The jigs ensure a stable base and help prevent tube damage. The integrated drill bushes specify the location of the threaded holes and guide the drill.

Dimensions in mm

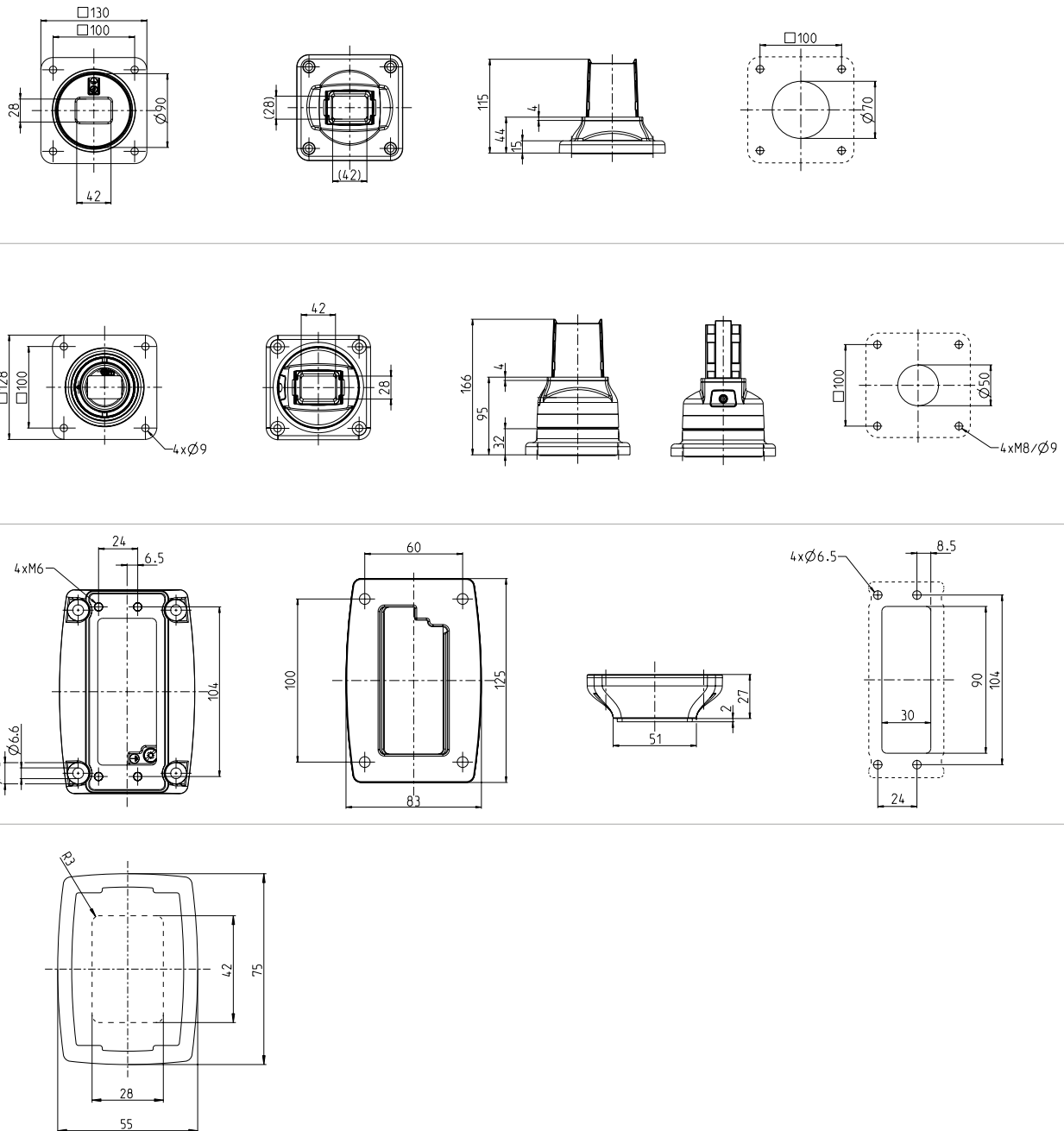

Quick adjustment ergo.slide
see pages 108 ff.



Stand base flex.base
see pages 118 ff.

The aluminium suspension system CS-3000

More than anything else, plant engineers demand variability, functionality, an advanced design and absolute ease of assembly from modern suspension systems. The CS-3000 suspension system is characterised by a combination of well thought-out ergonomics and modern industrial design. It consists of a large number of components that can be combined in any way. The CS-3000 suspension system is an innovative system solution that functions according to the modular principle.

Product features

- Suspension system for static loads up to 125 kg (with 1 m outrigger length)
- Suspension system for static load up to 80 kg with intermediate joint (with 1 m outrigger length)
- Continuous earthing concept
- Individual configurability
- High ease of cleaning: no dirty edges due to smooth transitions from tube to component
- Can be combined with CS-480 B.fleX suspension system (round tube)
- Many connections possible due to a large portfolio of components

Load diagram for static load CS-3000

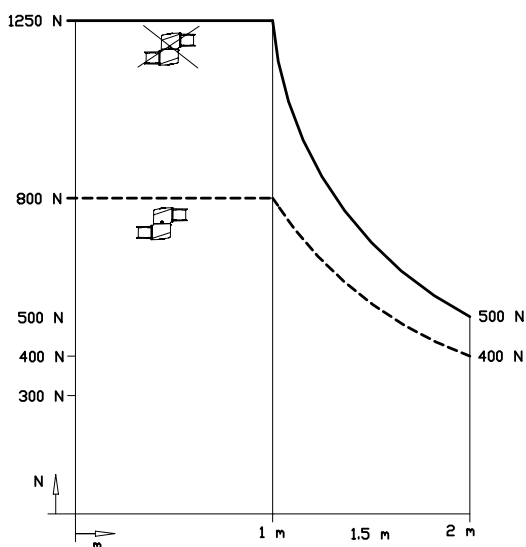

Application examples



CS-3000 suspension system with wall flange

- Wall flange/stand base CS-3000
- CS-3000 tube
- Turn/tilt coupling with operating enclosure CC-4000



Connection with wall joint based on the CS-3000 suspension system

Version with control unit

- Wall joint W rotatable CS-3000
- Reducing elbow CS-3000 to round tube 48 mm
- 48 tube
- CS-3000 tube
- 48 coupling

CS-3000 System advantages

Large mounting holes for easy cable handling



Easy readjustment

without dismantling the complete system



One-man assembly



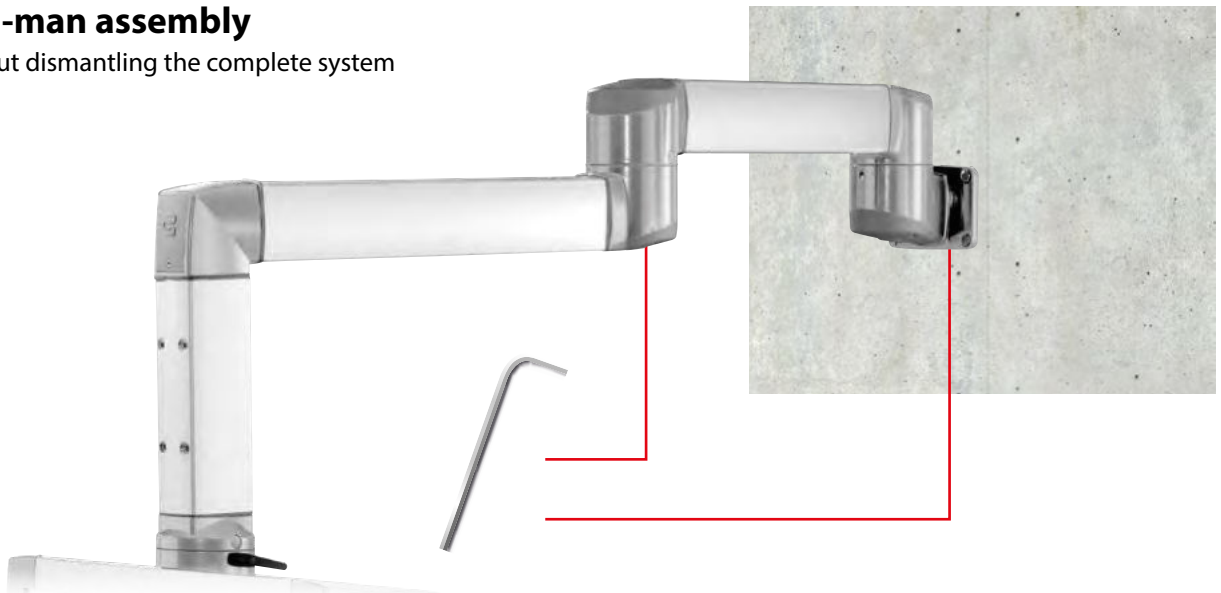



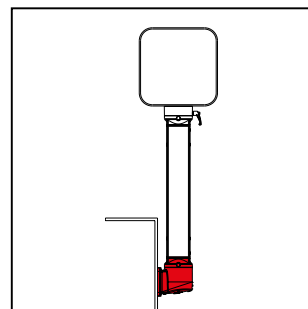
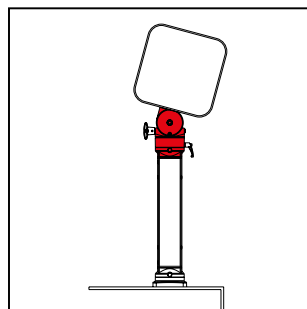
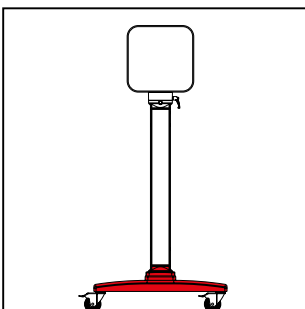
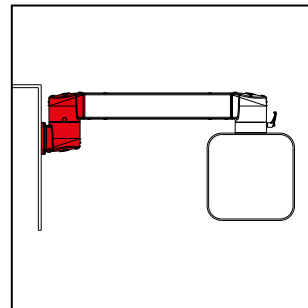
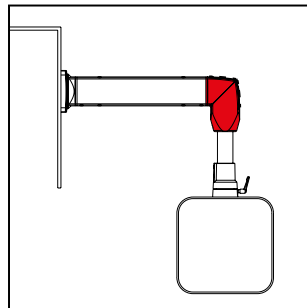
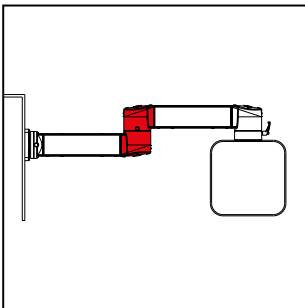
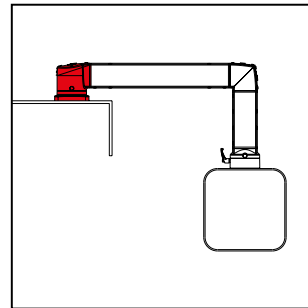
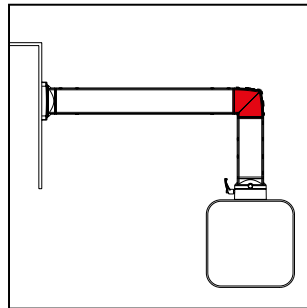
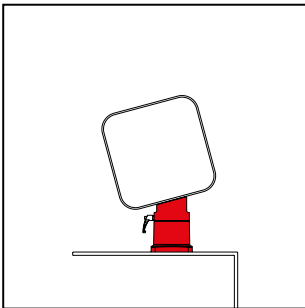
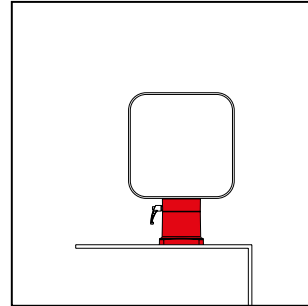
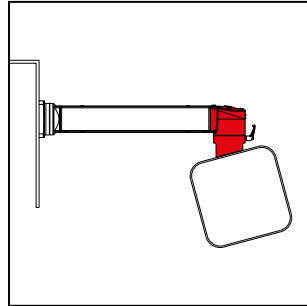
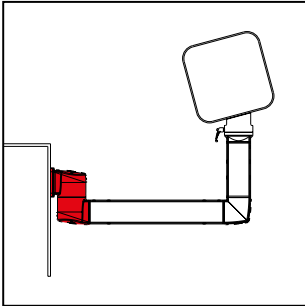

without dismantling the complete system

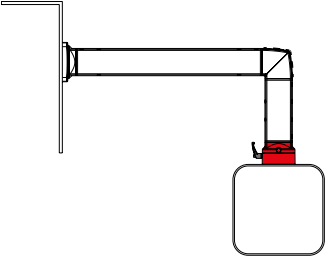

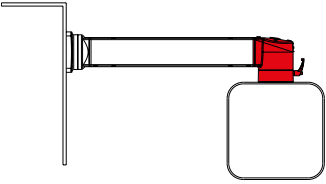
**Application examples CS-3000 suspension system –
Wide range of configuration options**

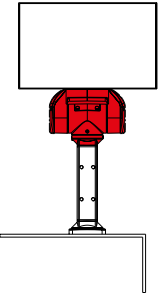

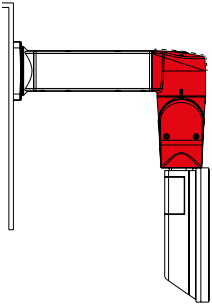
SUSPENSION SYSTEM CS-3000

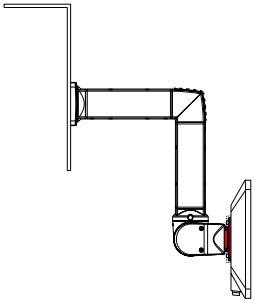
	Article	Application example
	<p>Coupling 1015300177 RAL 9006 white-aluminium</p> <ul style="list-style-type: none"> • Rotation angle 300° with stop • Adaptation to narrow enclosures < 101 mm • Weight: 1450 g 	
	<p>Elbow coupling 1015300178 RAL 9006 white-aluminium</p> <ul style="list-style-type: none"> • Rotation angle 300° with stop • Mounting opening incl. screwed plastic cover • Weight: 2070 g 	
	<p>Turn/tilt coupling S 1015300265 RAL 9006 white-aluminium (Tilt moment 50 Nm) 1015300273 RAL 9006 white-aluminium for panel (reduced tilt moment 29 Nm)</p> <ul style="list-style-type: none"> • For connecting panels / displays / IPC with screwed rear panel, adaptable mounting hole pattern • Rotation angle 300° with stop • Tilt angle with adjustable stop: +/- 105° (without attachments) • Screwed mounting opening, suitable for feed-through of DVI connectors • Weight: 4700 g 	
	<p>Turn/tilt coupling W 1015300262 RAL 9006 white-aluminium (Tilt moment 50 Nm) 1015300271 RAL 9006 white-aluminium for panel (reduced tilt moment 29 Nm)</p> <ul style="list-style-type: none"> • For connecting panels / displays / IPC with screwed rear panel, adaptable mounting hole pattern • Rotation angle 300° with stop • Tilt angle with adjustable stop: +/- 105° (without attachments) • Screwed mounting opening, suitable for feed-through of DVI connectors • Weight: 5200 g 	
	<p>Adapter plate VESA 75/100 9806000044 RAL 9006 white-aluminium</p> <ul style="list-style-type: none"> • This is an extra element required for the turn/tilt coupling: for rear-side connection to panels / displays / IPC with VESA 75/100 hole pattern • Weight: 300 g 	

Dimensions in mm

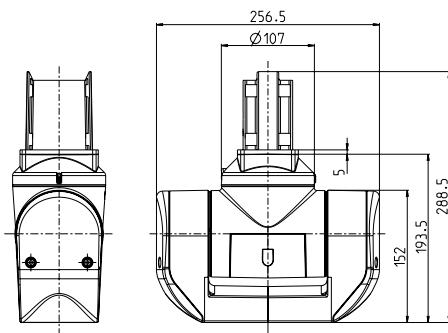
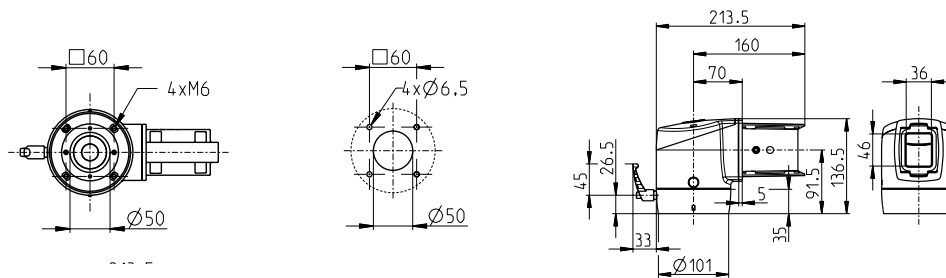
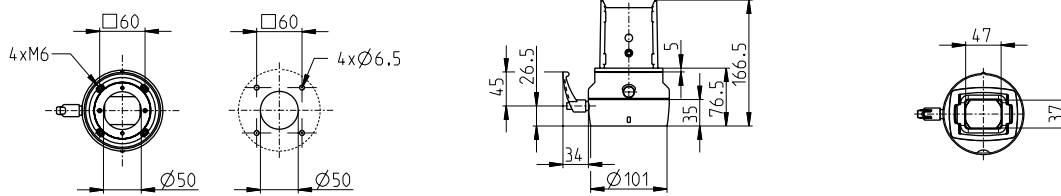

Connection diagram

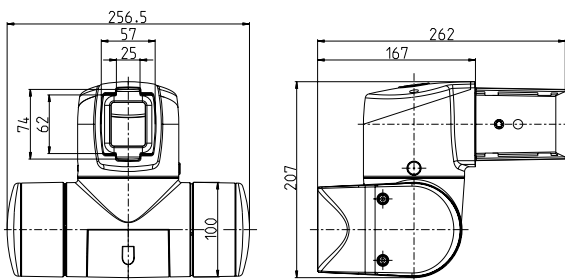
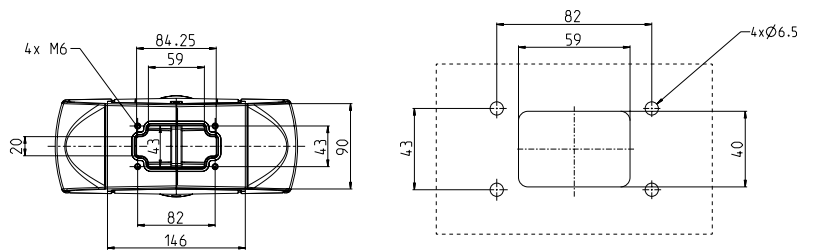

Connection diagram

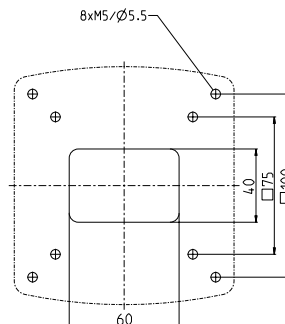
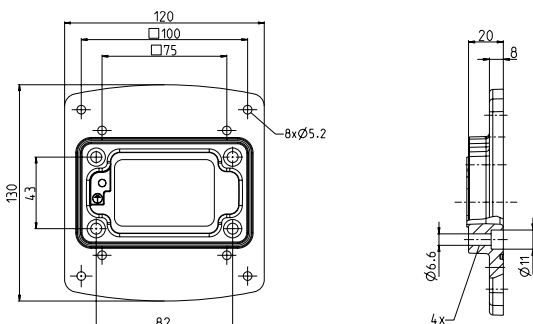
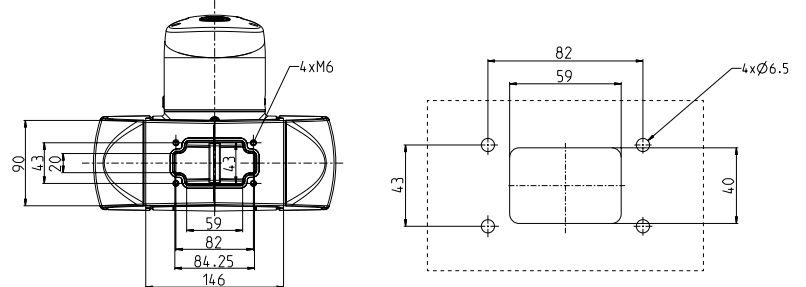







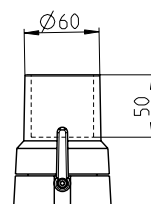
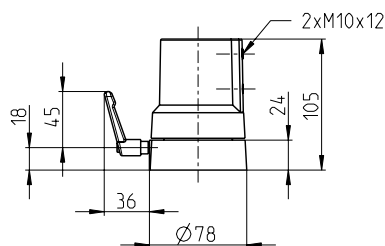
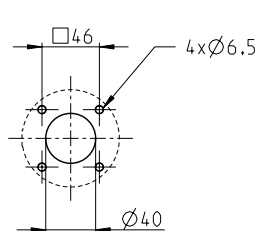
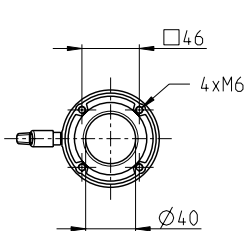
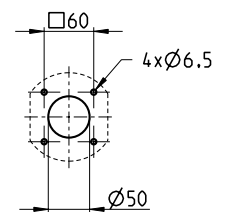
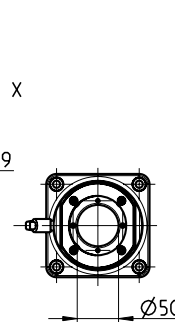
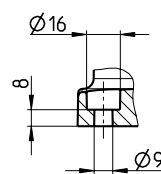
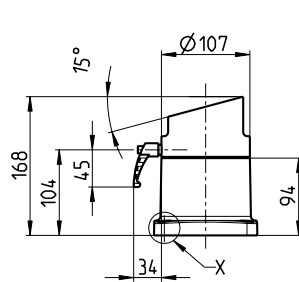
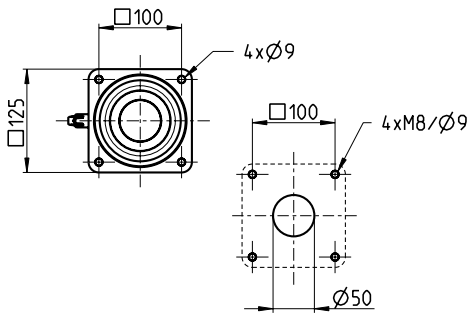
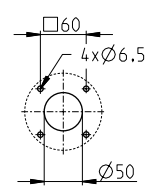
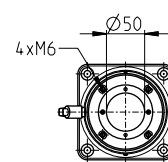
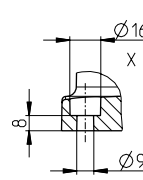
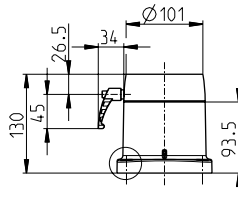
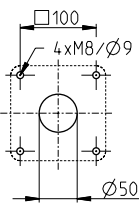
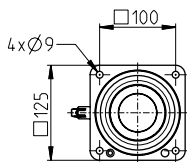
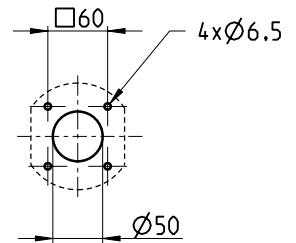
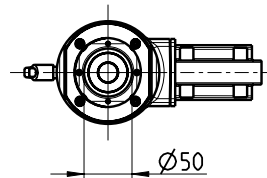
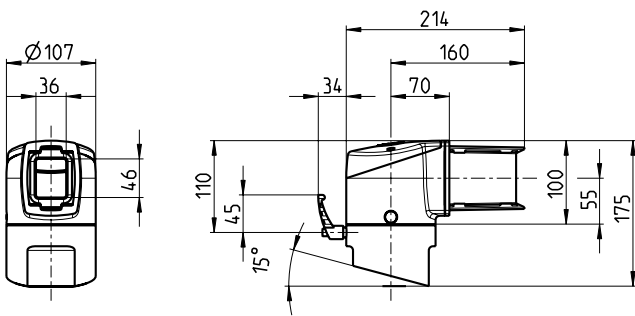
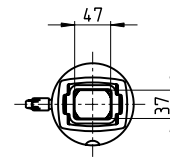
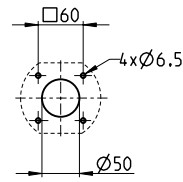
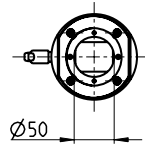
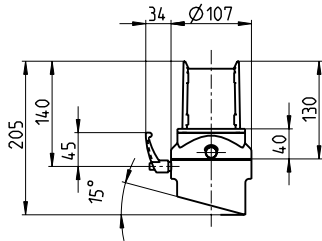

SUSPENSION SYSTEM CS-3000

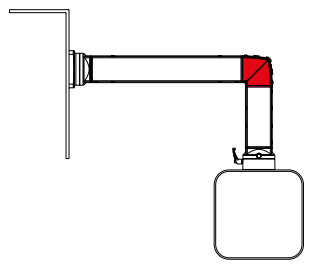
Article	Application example
	<p>Tilt coupling 15° A/B</p> <p>1015300179 A RAL 9006 white-aluminium 1015300180 B RAL 9006 white-aluminium</p> <ul style="list-style-type: none"> • Rotation angle 300° with stop • Fixed inclination of 15° (variant A inclined to the rear – variant B inclined to the front) • Weight: 1680 g
	
	<p>Tilt angle coupling 15° A/B</p> <p>1015300181 A RAL 9006 white-aluminium 1015300182 B RAL 9006 white-aluminium</p> <ul style="list-style-type: none"> • Rotation angle 300° with stop • Fixed inclination of 15° (variant A inclined to the rear – variant B inclined to the front) • Installation opening incl. screwed plastic cover • Weight: 2160 g
	
	<p>Stand coupling</p> <p>1015300183 RAL 9006 white-aluminium</p> <ul style="list-style-type: none"> • Rotation angle 300° with stop • Weight: 2120 g
	
	<p>Tilt stand coupling 15° A/B</p> <p>1015300184 A RAL 9006 white-aluminium 1015300185 B RAL 9006 white-aluminium</p> <ul style="list-style-type: none"> • Rotation angle 300° with stop • Fixed inclination of 15° (variant A inclined to the rear – variant B inclined to the front) • Weight: 2340 g
	
	<p>Coupling 48</p> <p>1013056000 RAL 9006 white-aluminium</p> <ul style="list-style-type: none"> • Rotation angle 300° with stop • Only compatible with 48 mm round tubing • Weight: 1760 g
	

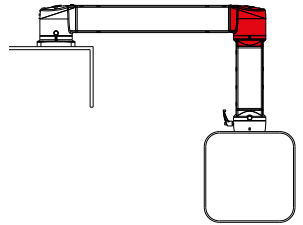
Dimensions in mm

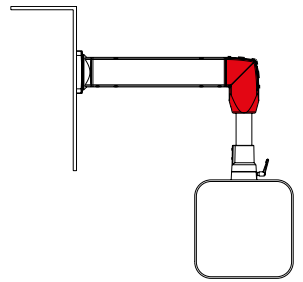

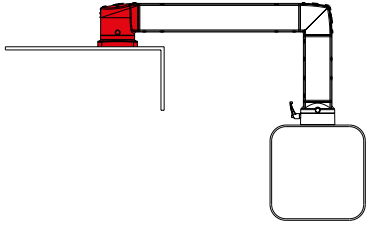

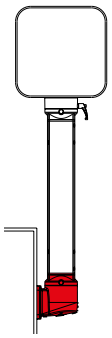



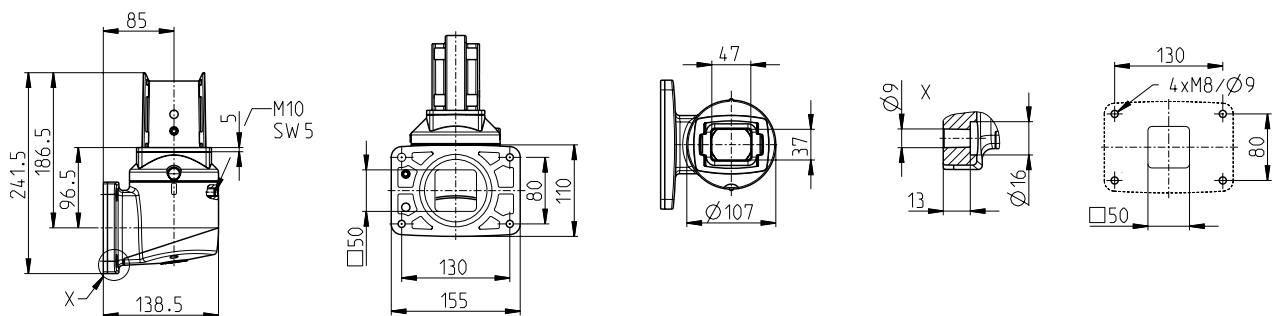
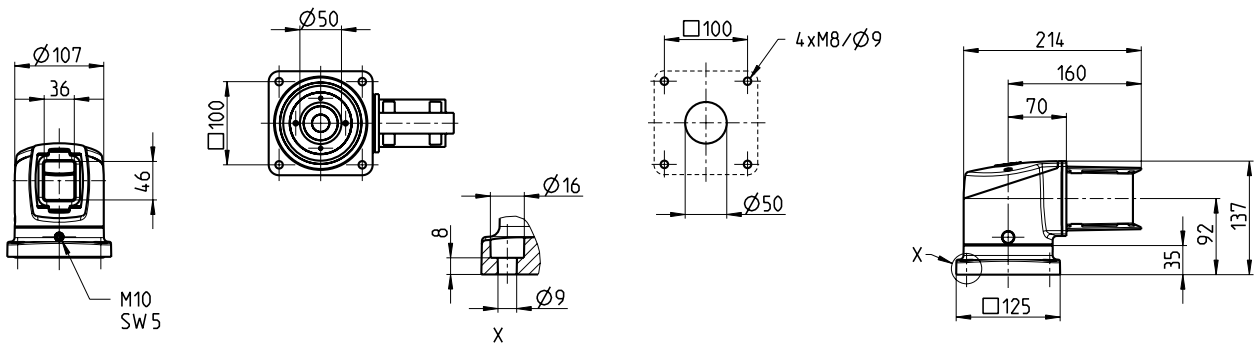
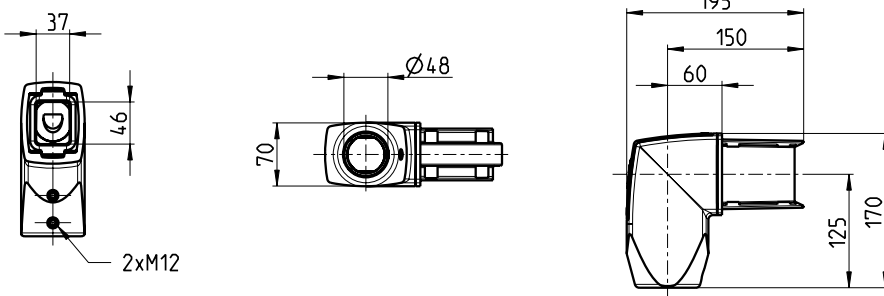
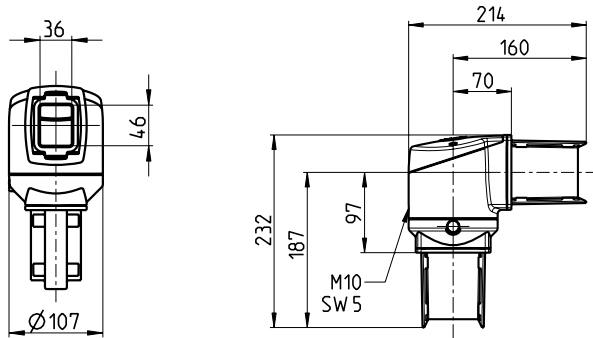
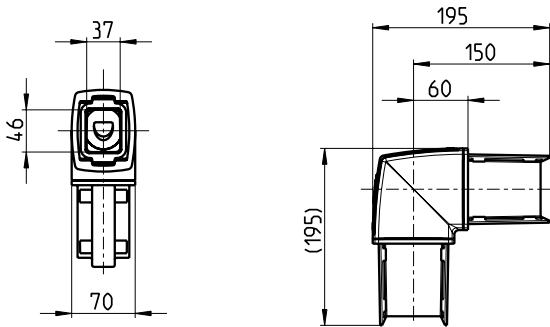

SUSPENSION SYSTEM CS-3000

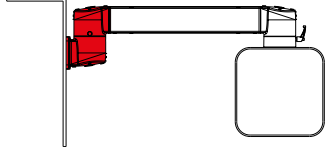
Article	Application example
 <p>Elbow 1015300195 RAL 9006 white-aluminium</p> <ul style="list-style-type: none"> • Installation opening incl. screwed plastic cover • Weight: 1680 g 	
 <p>Elbow rotatable 1015300196 RAL 9006 white-aluminium</p> <ul style="list-style-type: none"> • Rotation angle 300° with stop • Installation opening incl. screwed plastic cover • Weight: 2460 g 	
 <p>Elbow reduced RD 48 1015300197 RAL 9006 white-aluminium</p> <ul style="list-style-type: none"> • Reduction elbow from the square tube to the 48 mm round tubing • Weight: 1920 g 	
 <p>Attachment joint 1015300198 RAL 9006 white-aluminium</p> <ul style="list-style-type: none"> • Rotation angle 300° with stop • Installation opening incl. screwed plastic cover • Weight: 2250 g 	
 <p>Wall joint S 1015300199 RAL 9006 white-aluminium</p> <ul style="list-style-type: none"> • Rotation angle 300° with stop • Installation opening including screw-fit plastic cover • Weight: 2449 g 	

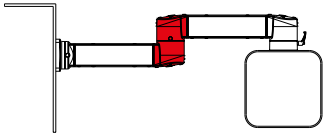
Dimensions in mm

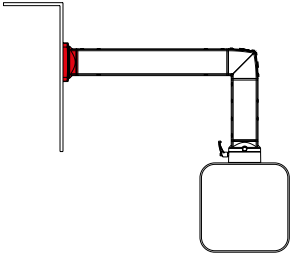

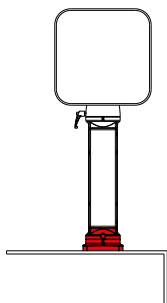
SUSPENSION SYSTEM CS-3000

Article	Application example
 <p>Wall joint W 1015300200 RAL 9006 white-aluminium</p> <ul style="list-style-type: none"> • Rotation angle 300° with stop • 2 installation openings incl. screwed plastic cover • Weight: 2930 g 	
 <p>Intermediate joint 1015300201 RAL 9006 white-aluminium</p> <ul style="list-style-type: none"> • Rotation angle 300° with stop • 2 installation openings incl. screwed plastic cover • Weight: 2940 g 	
 <p>Stand base / wall flange 1015300204 RAL 9006 white-aluminium</p> <ul style="list-style-type: none"> • Weight: 1300 g 	
 <p>Rotatable stand base 1015300205 RAL 9006 white-aluminium</p> <ul style="list-style-type: none"> • Rotation angle 300° with stop • Weight: 1780 g 	
 <p>SIMATIC Pro® Adapter 9806942000 RAL 9006 - normal 9806940000 RAL 9006 - tilted 15° A/B</p> <ul style="list-style-type: none"> • Is used for the direct connection between Siemens SIMATIC Pro® Displays and CS-3000 couplings and tilt couplings • Weight: 140 g 	

Dimensions in mm

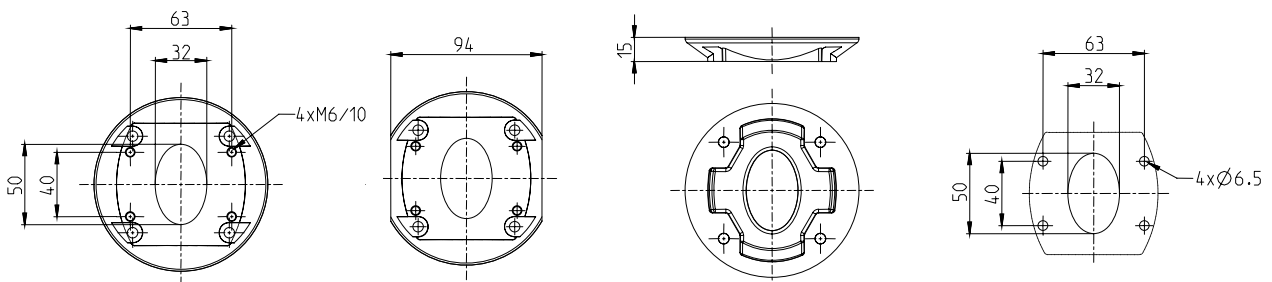
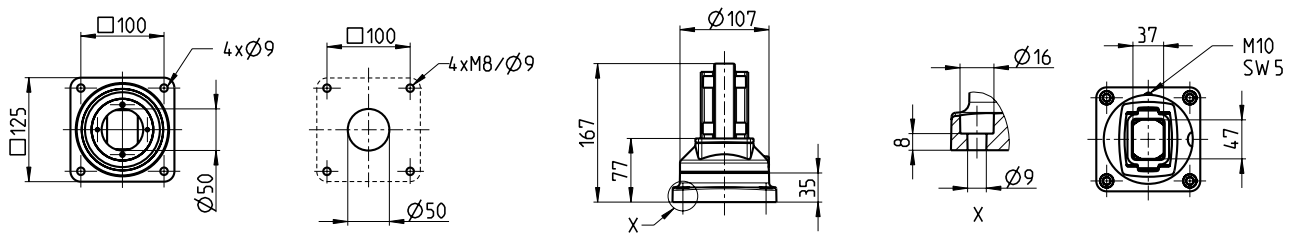
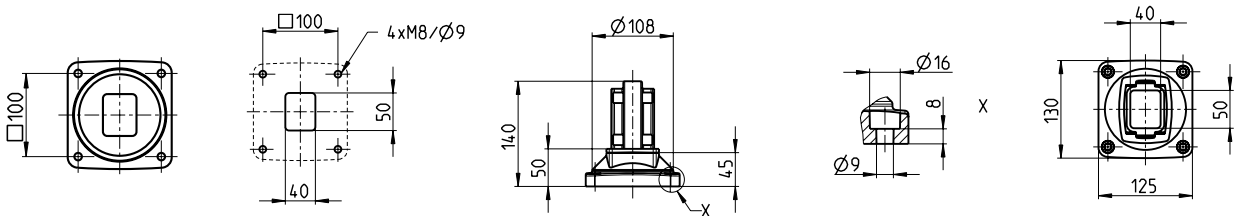
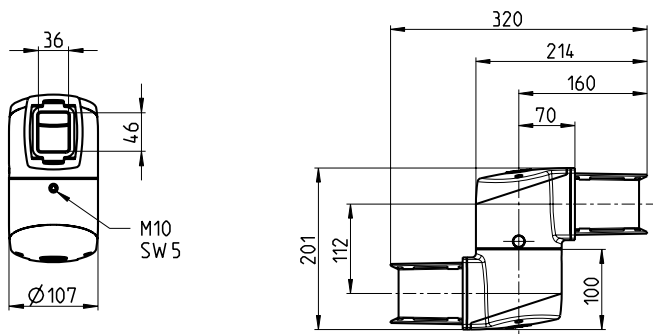
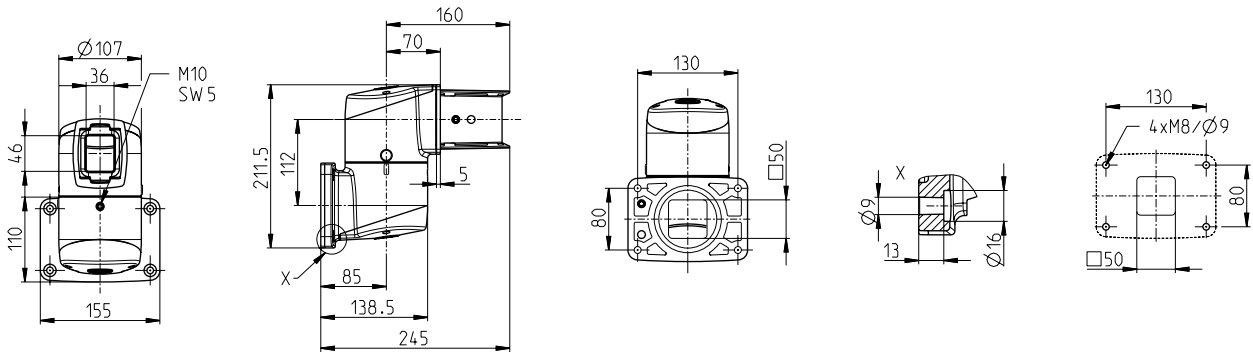

SUSPENSION SYSTEM CS-3000

Article	Application example
---------	---------------------



Tube adapter

1015300208 RAL 9006 white-aluminium

- After shortening the tube, the adapter is screwed to the tube; the tube adapter is then fixed to the component and the system can be adjusted.
- Weight: 720 g

Attention: Always mount the tube adapter on the enclosure side, see application example!

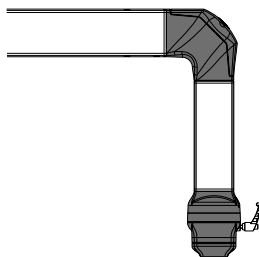
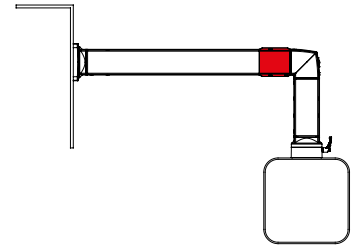

Adaption on narrow enclosures

Connection to enclosures with widths < 101 mm in combination with the CS-3000 neXt suspension system;

Required components:
Reducing elbow, coupling, adapter for narrow enclosures

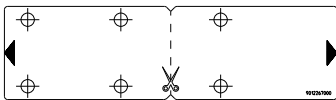
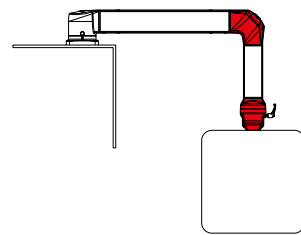

Drill label for special tube lengths

9012267000

With the help of the self-adhesive drilling template, you can drill precisely in position. Simply select the appropriate tube profile and order the number of drilling templates required.



Drilling jigs for special tube lengths

9806935000 Four-part set

The drilling jigs are pushed onto the already shortened tube. The fixtures enable stable clamping without damage to the tube. The integrated drilling aids determine the position of the threaded holes and guide the drill.



Quick adjustment ergo slide
see pages 108 ff.

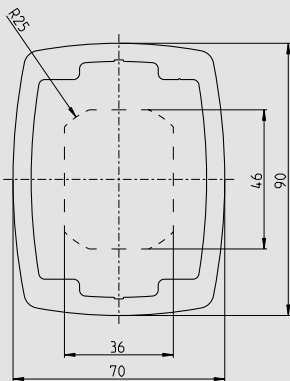
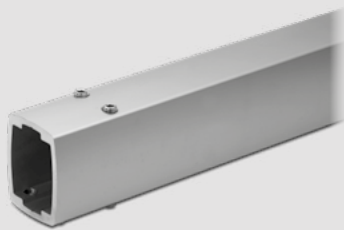
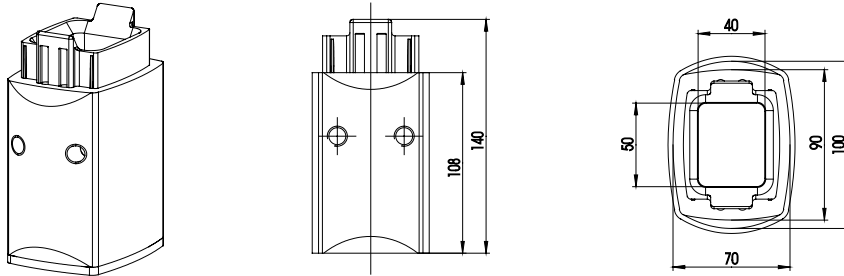

Stand base flex base
see pages 118 ff.

Dimensions in mm

Tube profiles

Standard lengths (available from stock)	Article number	Weights in kg
Tube cross-section x Length		
70 x 90 x 250 mm	9524500001	1.30
70 x 90 x 500 mm	9524500002	2.50
70 x 90 x 750 mm	9524500003	3.70
70 x 90 x 1000 mm	9524500004	5.00
70 x 90 x 1250 mm	9524500005	6.20
70 x 90 x 1500 mm	9524500006	7.50
70 x 90 x 1750 mm	9524500007	8.70
70 x 90 x 2000 mm	9524500008	10.00
Tubes machined on one side (machining templates supplied, available from stock)		
70 x 90 x 1000 mm	9524500009	5.00
70 x 90 x 2000 mm	9524500010	10.00

If one of our standard lengths is not sufficient, you can also ask for tubes machined on one side from us. Simply shorten to your desired length and process the shortened side using the enclosed template.

The heavy duty CS-2000 System 80

A steel support system is the ideal solution for the stable and reliable connection of controls in machine and plant construction. The CS-2000 System 80 features solid steel support profiles and a wide range of system components and couplings. This allows for a wide range of system solutions to be realised of up to a 3 m projection and a 150 kg load. Generous installation openings allow for easy cable installation. Accessories such as swivel angle limiters or traffic light adapters round off the product range.

Product features

- Installation openings at all deflection points for simplified cable installation
- Integrated strain relief for intercepting cables
- Maintenance-free and backlash-free bearings in all joints and couplings
- Adjustment options for exact alignment of the support tubes
- Wall and intermediate joints with adjustable torque and retrofittable swivel angle limitation (available as accessories)
- Flange couplings with adjustable sluggishness and retrofittable angle of rotation limitation
- "Overhead mounting" of all components possible

Load diagram for static load CS-2000 System 80

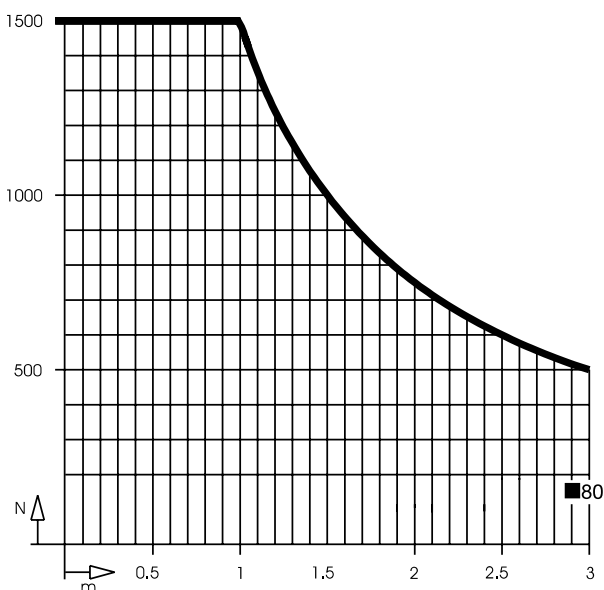

Application examples



CS-2000 System 80 suspension system with CC-3000 operating enclosure

- Support column
- Hanging version



Suspension system CS-2000 System 80 Connection from above

- Wall joint with bellows
- Elbow
- CS-2000 Support tube
- Coupling on CC-4000



CS-2000 System 80 suspension system with CC-4000 operating enclosure

- Support column
- Standing version



Suspension system CS-2000 System 80 Connection from below

- Coupling on CC-4000
- CS-2000 Support tube
- Elbow
- Wall joint with bellows

SUSPENSION SYSTEM CS-2000 System 80

Materials

- Aluminium components: Cast aluminium
- Cast steel components: GGG 40
- Welded steel constructions
- Support tubes: St 37
- Bearing: St/PTFE bzw. POM
- Seals: CR
- Installation openings: Cast aluminium
- Bellows: PVC

Colours

- Suspension system components: light grey, RAL7035
- Bellows: light grey, RAL7035
- Tubes: light grey, RAL7035

Large cable or installation openings

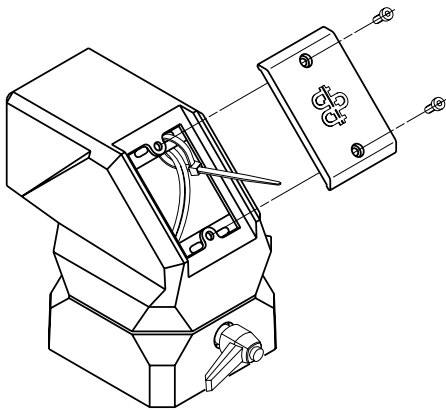

**The reliable partner for
high load-bearing capacities
in the industrial sector**

**Application examples Suspension system CS-2000 System 80 –
Wide range of configuration options**

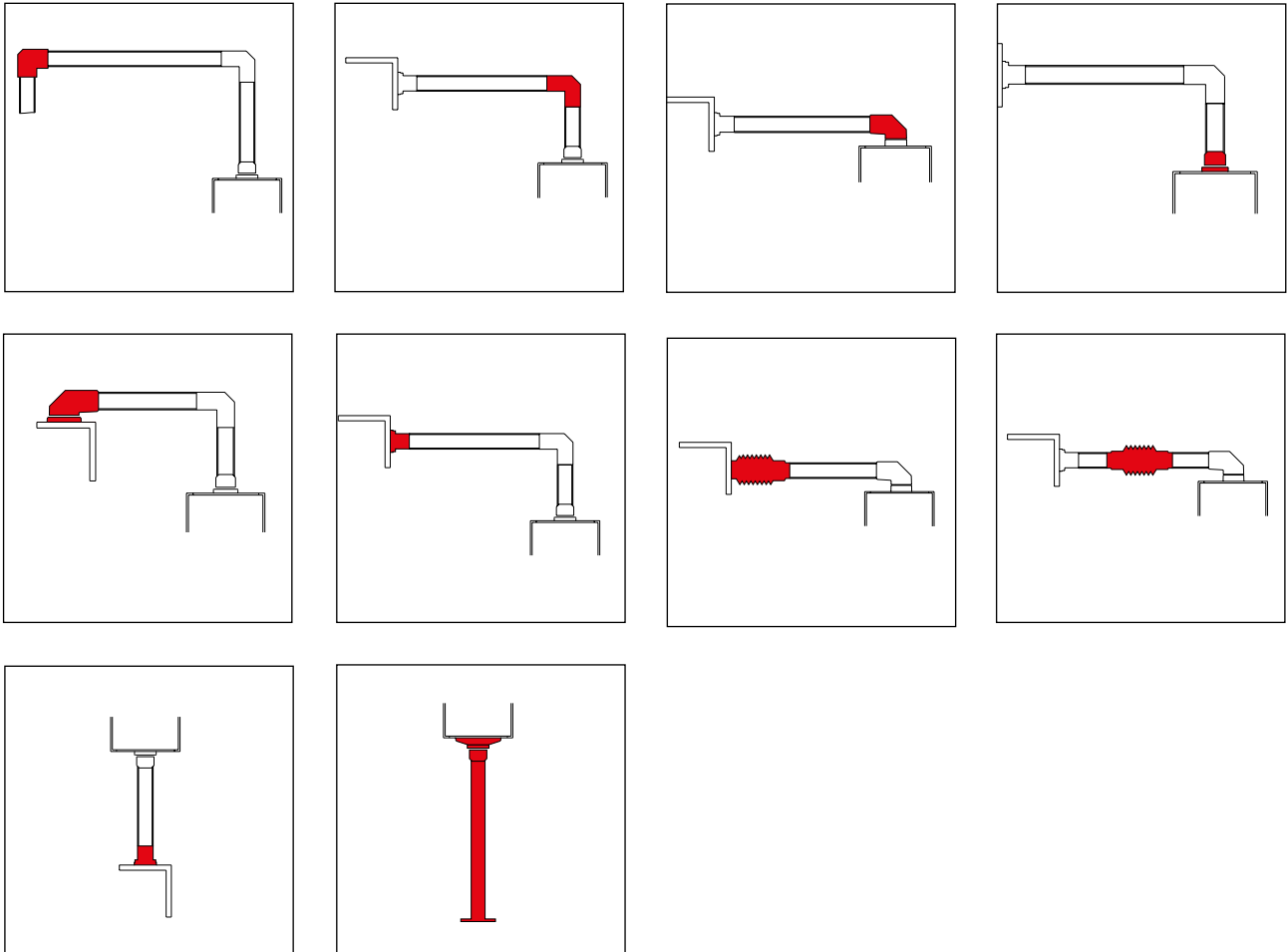

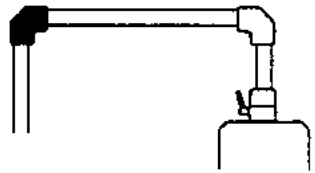

SUSPENSION SYSTEM CS-2000 System 80

Article	Application example
 <p>Standard coupling, flange 1016702000 RAL7035 light grey</p> <ul style="list-style-type: none"> • Rotation angle 300° with stop • Complete with seals and fixing screws • Torque adjustable • Material: Aluminium • Weight: 3270 g 	
 <p>Elbow coupling, flange 1016705000 RAL7035 light grey</p> <ul style="list-style-type: none"> • Rotation angle 300° with stop • Complete with seals and fixing screws • Torque adjustable • Installation opening • Material: Aluminium • Weight: 4100 g 	
 <p>Elbow 1016708000 RAL7035 light grey</p> <ul style="list-style-type: none"> • Installation opening • Complete with seals • Material: Aluminium • Weight: 2900 g 	
 <p>Elbow for moment load 1016711000 RAL7035 light grey</p> <ul style="list-style-type: none"> • Increased load capacity • Complete with seals • Installation opening • Material: GGG • Weight: 8500 g 	
 <p>Intermediate joint 1016471000 RAL7035 light grey</p> <ul style="list-style-type: none"> • Bellows attached with a zip • Swivel angle 180° with stop on both sides • Torque adjustment • Material: Steel • Weight: 9700 g 	

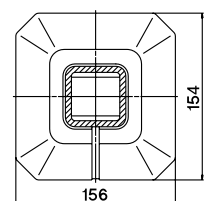
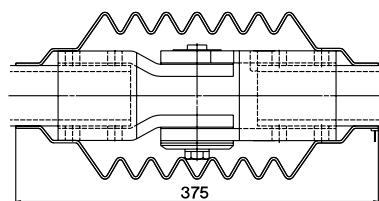
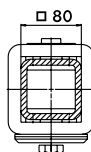
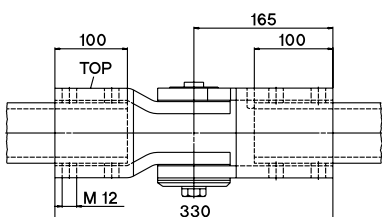
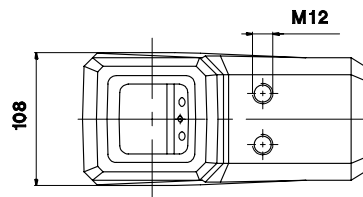
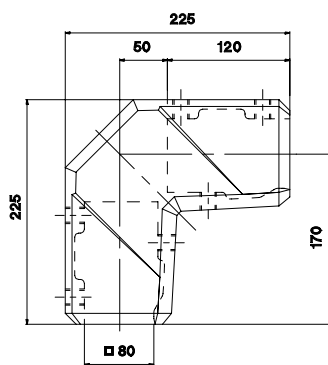
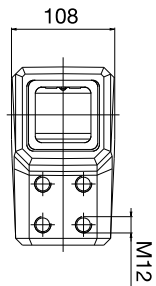
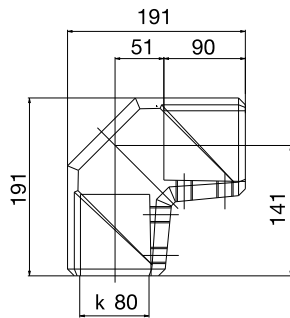
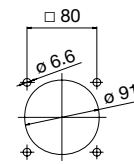
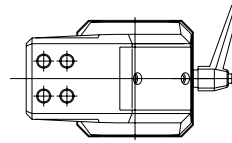
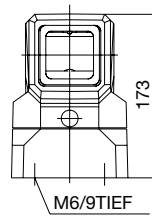
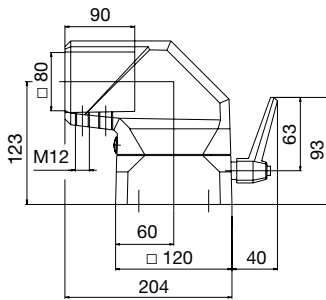
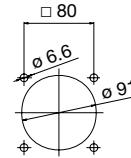
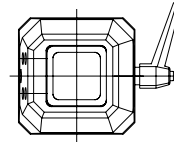
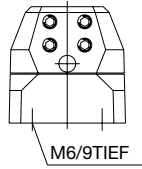
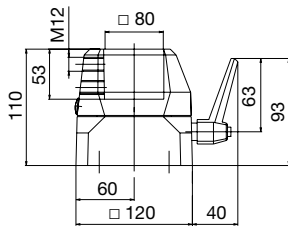
Dimensions in mm

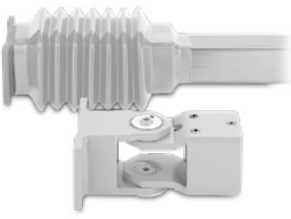
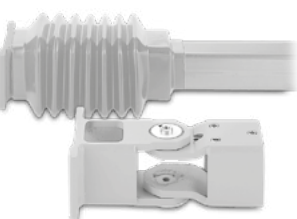

SUSPENSION SYSTEM CS-2000 System 80

Article	Application example
	<p>Top joint 1016714000 RAL7035 light grey</p> <ul style="list-style-type: none">• Rotation angle 306° with stop• Complete with seals and mounting screws• Material: GGG• Weight: 20620 g
	<p>Wall joint 1016473000 RAL7035 light grey</p> <ul style="list-style-type: none">• Bellows attached with a zip• Swivel angle 180° with stop on both sides• Torque adjustment• Material: Steel• Weight: 9250 g
	<p>Wall joint for cable entry 1016474000 RAL7035 light grey</p> <ul style="list-style-type: none">• Bellows attached with a zip• Swivel angle 180° with stop on both sides• Torque adjustment• Material: Steel• Weight: 9500 g
	<p>Wall flange 1016472000 RAL7035 light grey</p> <ul style="list-style-type: none">• Complete with seals• Material: GGG• Weight: 9100 g
	<p>Base 1016475000 RAL7035 light grey</p> <ul style="list-style-type: none">• Complete with seals• Material: GGG• Weight: 9240 g

Dimensions in mm

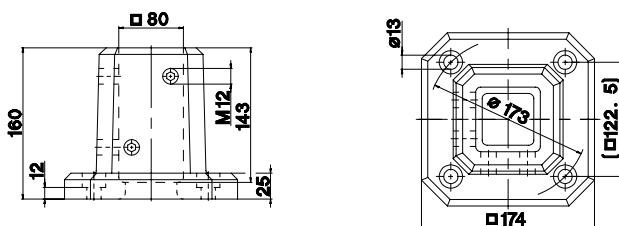
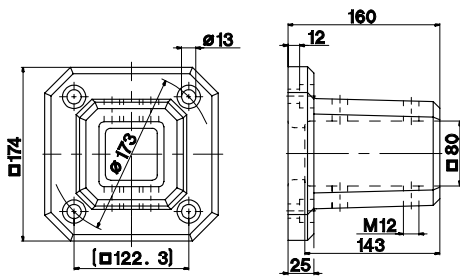
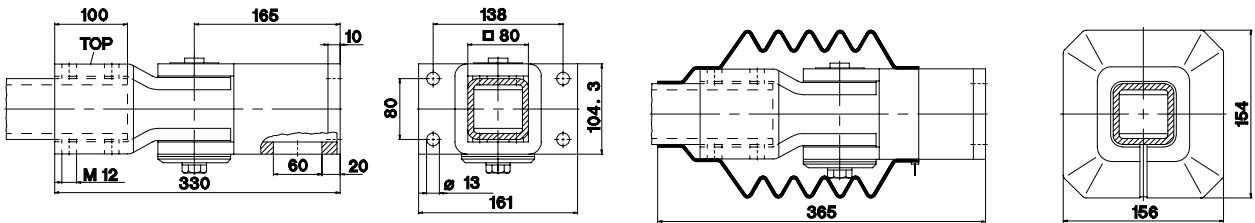
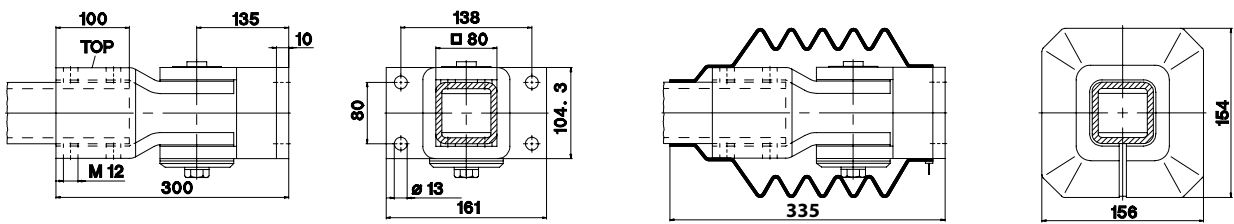
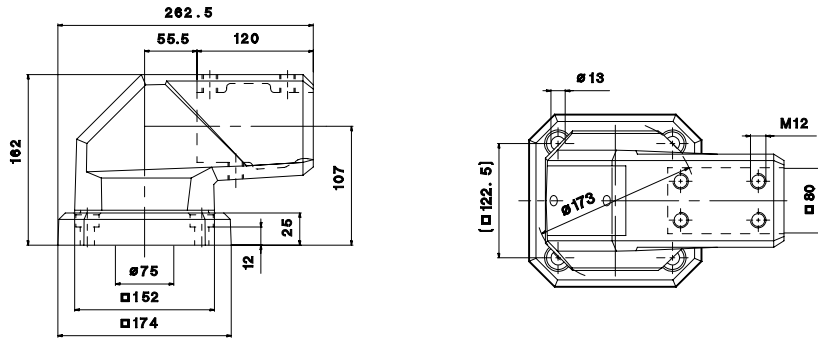

SUSPENSION SYSTEM CS-2000 System 80

Article	Application example
---------	---------------------

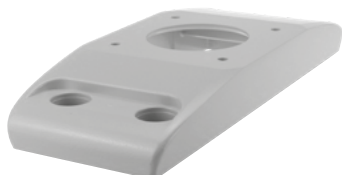

Automotive adapter

1016898000 RAL7035 light grey

- Material: Aluminium
- Weight: 1100 g

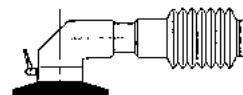

Support column, standing version

1016558000 RAL7035 light grey

- Material: Steel / Aluminium
- Weight: 27220 g

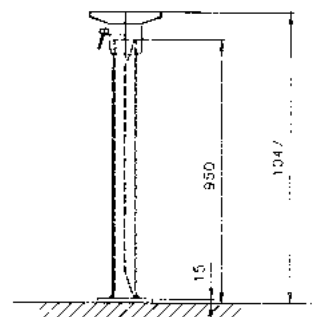

Tube profiles RAL7035 light grey

Available tube lengths	Article number	Weights in kg
Length mm		
250 mm	9527114000	2.0
500 mm	9527115000	5.30
750 mm	9527116000	8.10
1000 mm	9527117000	11.00
1250 mm	9527118000	13.50
1500 mm	9527119000	16.50
2000 mm	9527121000	21.20
3000 mm	9527123000	33.00

Dimensions in mm

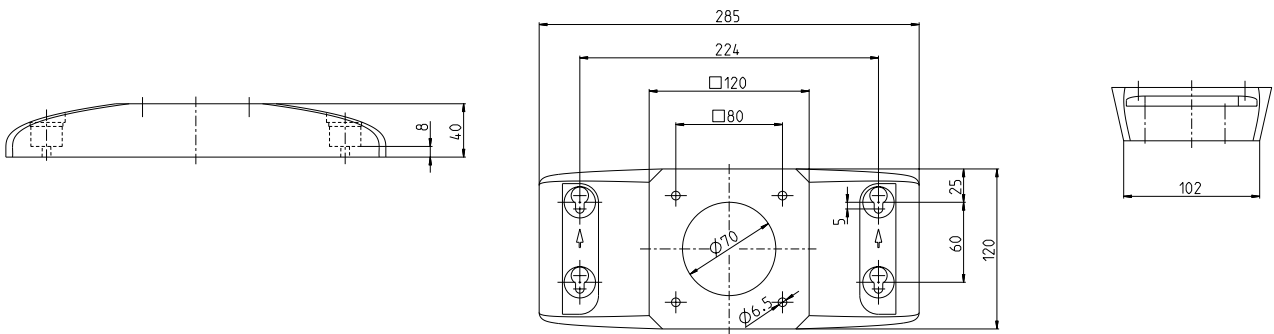

SUSPENSION SYSTEM CS-2000 System 80

Accessories

Article



Swivel angle limiter for coupling components

9805176000

- Easy to retrofit
- Balls limit the swivel angle after installation
- Adjustable in steps of 9°
- Material: PA



Signal lamp adapter

9805189000 Elbow components RAL7035 light grey
9805188000 Top joint RAL7035 light grey

- Easy to retrofit
- Installation opening for signal lamp tubes with an outside diameter of 25 mm
- Fixation by threaded pins on the sides
- Material: Aluminium



Swivel angle limiter for wall and intermediate joints

9805062000

- A retrofittable accessory set for wall and intermediate joints
- Swivel angle range adjustable and fixed in steps of 15°
- Material: Steel

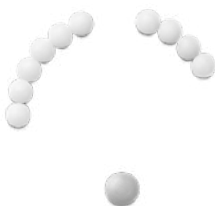

Swivel angle limitation for joint components

9805177000

- Easy to retrofit
- Balls limit the swivel angle after installation
- Adjustable in steps of 8.5°
- Material: PA



Swivel angle limiter for turn / tilt couplings

9805130000

- Easy to retrofit
- Balls limit the swivel angle after installation
- Adjustable in steps of 8.5°
- Material: PA

Notes



Diagrams. Sketches. Ideas.

A large, empty grid of small dots arranged in a regular pattern, intended for sketching or drawing.

CS-480 B.flex — Flexible round tube system for connecting IPCs and operating enclosures

Operating enclosures or IPCs mounted on ceilings, walls or on the floor are often easier and more ergonomic to position if the user can quickly adjust them to their personal needs. The CS-480 B.flex suspension system from BERNSTEIN AG is suitable for such use. It can also be combined with the CS-3000 suspension system without any problems. The reducing elbow functions as a connection and transition from a round to a square tube. The elbow rotatable also allows for a connection to the CS-3000neXt system.

Product features

- Simplest and most cost-effective solution for hanging and free-standing operator stations
- Quick and easy ergonomic adjustment
- Continuous equipotential bonding
- Maximum cable diameter: \varnothing 40 mm
- Flexible and cost-effective connection from round to square tubing
- Easy to retrofit – complete exchange of the existing suspension system is not necessary
- Temperature range $-5\text{ }^{\circ}\text{C}$ to $+70\text{ }^{\circ}\text{C}$
- Suspension system conforms to protection class IP65 according to IEC 60529

Load diagram for a static load CS-480 B.flex

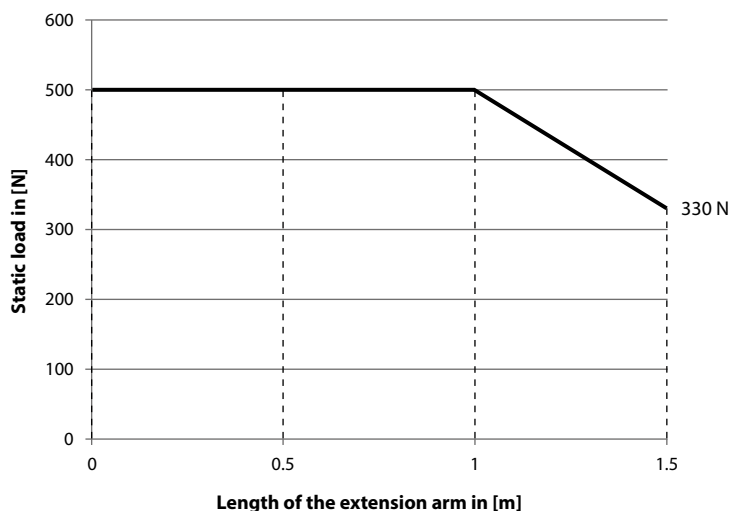

Application examples



CS-480 B.flex Wall-mounted variant

- IPC
- Panel coupling
- 48 tube
- Wall joint



CS-480 B.flex Wall-mounted variant

- IPC
- Turn/tilt coupling
- 48 tube
- Wall joint

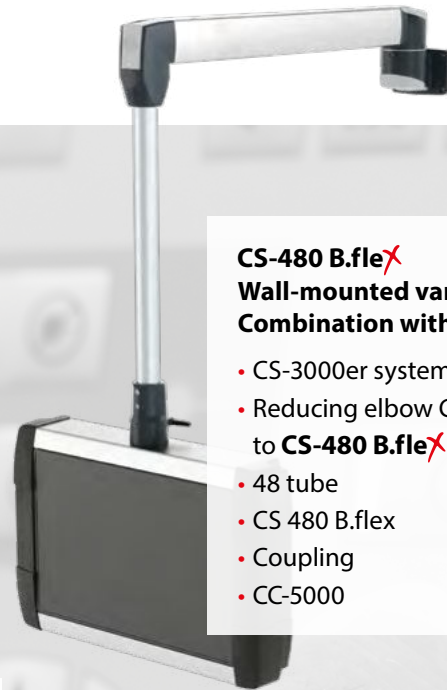

CS-480 B.flex Wall-mounted variant Combination with CS-3000

- CS-3000er system
- Reducing elbow CS-3000 to CS-480 B.flex
- 48 tube
- CS 480 B.flex
- Coupling
- CC-5000



CS-480 B.flex Connection from below with coupling and stand base

- CC-3000 with front panel and Push-button module
- Signal lamp
- CS 480 B.flex coupling
- 48 mm tube
- CS 480 B.flex stand base fixed



CS-480 B.flex Connection from below with coupling and stand base

- CC-5000 next
- Coupling
- 48 tube
- Stand base fixed

Individually ergonomic. Flexible and fast.

Thanks to its many variable suspension systems, operating elements and flexible expansion possibilities, BERNSTEIN offers the appropriate solution for every industrial work place.

Standing, turning, angling, tilting or hanging: BERNSTEIN offers the perfect solution for every customer requirement.

B.flex — B.BERNSTEIN



Connection possibilities

- Operating enclosures with support surface of at least 81 mm
- Encapsulated IPCs with fixed Ø 48 mm round tube connection
- Encapsulated IPCs with rotatable Ø 48 mm round tube connection

Flexible system components

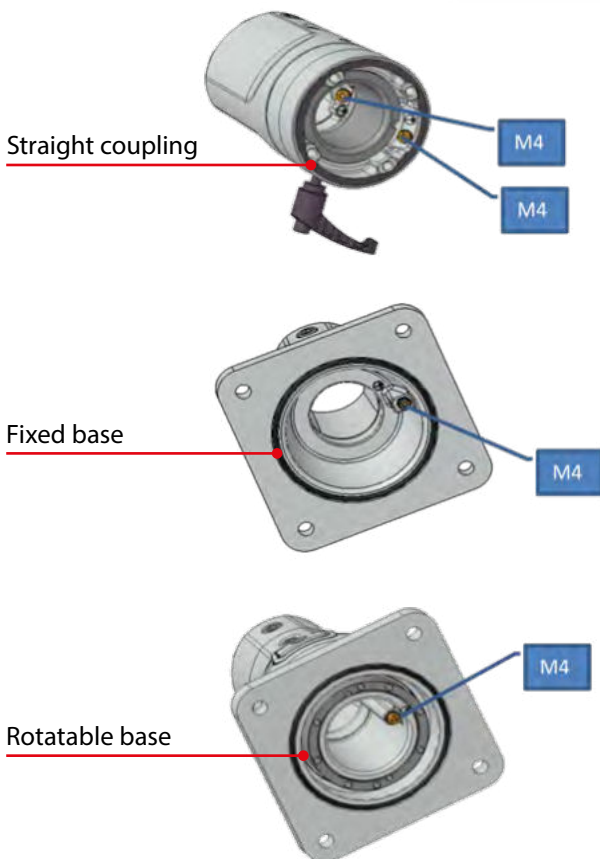

Example presentations



Small but powerful

The CS-480 B.flex is the smallest self-contained suspension system from BERNSTEIN.

The 48 mm round tube for connecting encapsulated IPCs or operating enclosures to machines and systems is certainly not large, but it does provide for individual flexibility.

From light suspension system to the heavy-duty suspension system

BERNSTEIN'S smallest connection solution for encapsulated IPCs and operating enclosures

Usual conditions

- Temperature range -5 °C to $+70\text{ °C}$
- Suspension system conforms to protection class IP65 according to IEC 60529
- Suspension system may only be used under a rated voltage not exceeding 400 V AC or 48 V DC and for general indoor use.

Conformity to standards

- Directive 2014/35/EU Edition 26.02.2014 (Electrical equipment for use within certain voltage limits)
- Directive 93/68/EWG/Regulation 768/2008 Edition 13.08.2008 (CE conformity marking)
- Directive 2002/95/EG resp. 2001/65/EG (RoHs)





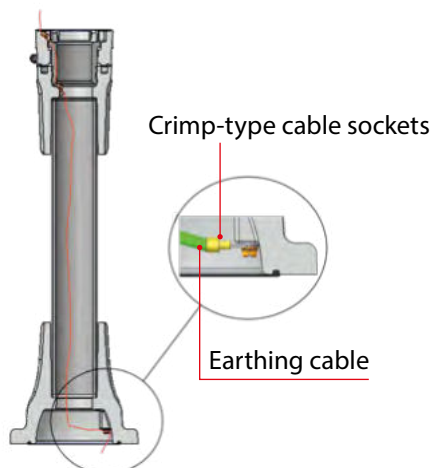



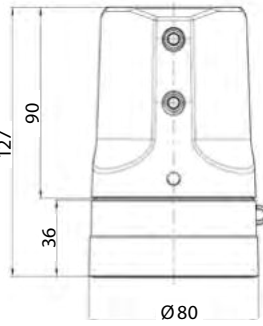

Earthing example

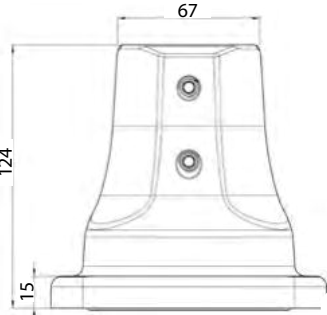

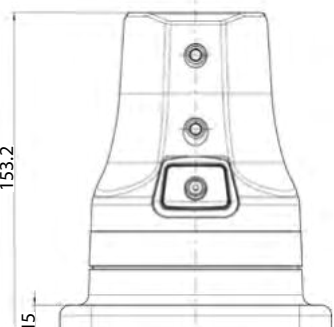
The system components from BERNSTEIN are characterised by internal equipotential bonding and a separate protective conductor. The separate protective conductor connection is a feature that sets us apart from our competitors.

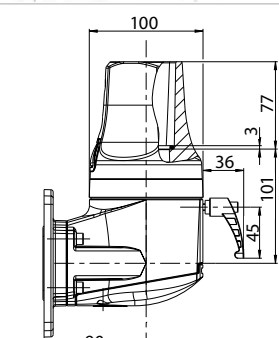

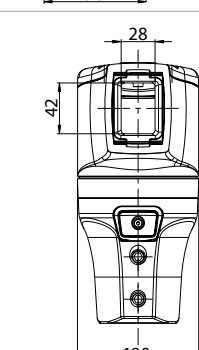

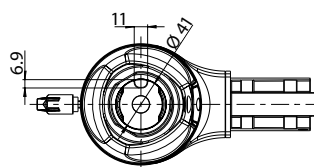
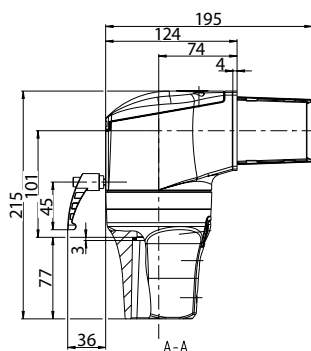
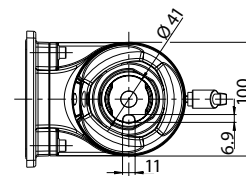
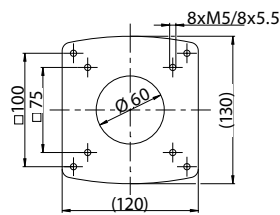
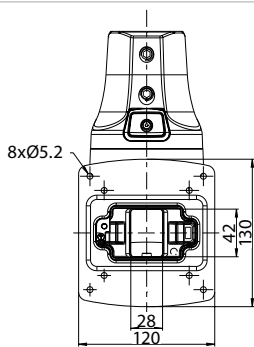
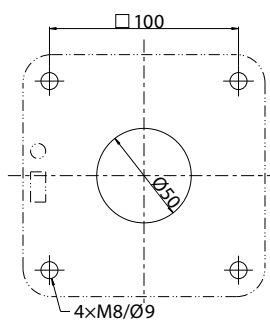
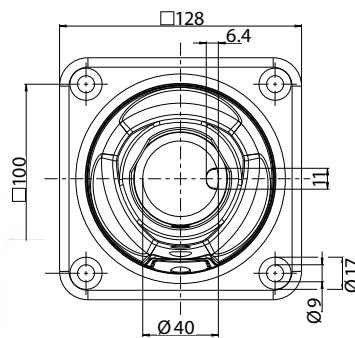
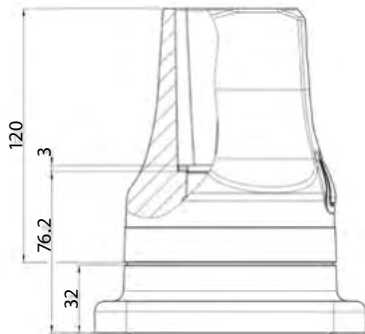
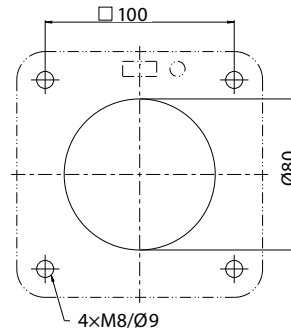
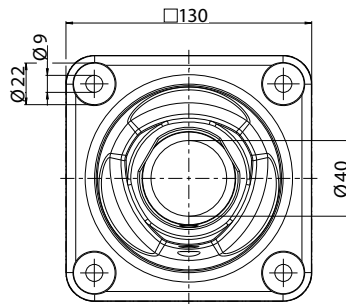
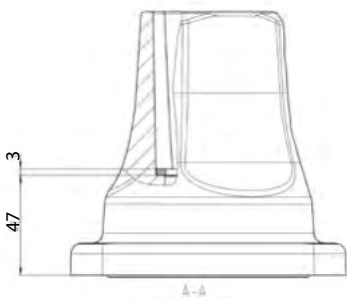
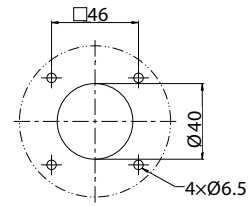
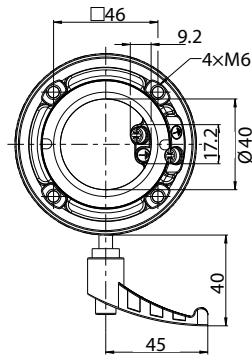
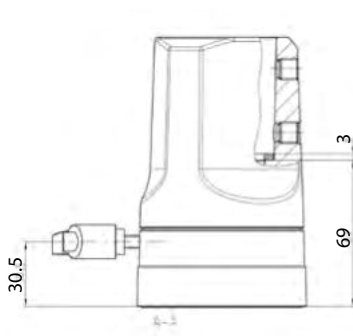

SUSPENSION SYSTEM CS-480 B.fleX

	Article	Dimensions in mm
	<p>Coupling rotatable 1014800001 RAL 9006 white-aluminium*</p> <ul style="list-style-type: none"> Aluminium die-casting Rotation angle 300° with stop Weight: 957 g Connection for equipotential bonding 	 <p>Technical drawing showing dimensions: 127 (total height), 90 (height to top), 36 (height to bottom), and Ø 80 (diameter).</p>
	<p>Stand base fixed 1014800013 RAL 9006 white-aluminium *</p> <ul style="list-style-type: none"> Aluminium die-casting Weight: 1273 g Connection for equipotential bonding 	 <p>Technical drawing showing dimensions: 67 (width), 124 (height), and 15 (base thickness).</p>
	<p>Stand base rotatable 1014800014 RAL 9006 white-aluminium *</p> <ul style="list-style-type: none"> Aluminium die-casting Rotation angle 300° with stop Optional swing angle limitation Weight: 1917 g Connection for equipotential bonding 	 <p>Technical drawing showing dimensions: 153.2 (total height), 15 (base thickness), and a square base.</p>
	<p>Panel coupling S 1014800003 RAL 9006 white-aluminium *</p> <ul style="list-style-type: none"> Aluminium die-casting Rotation angle 300° with stop Weight: 2668 g Connection for equipotential bonding Standard hole pattern VESA 75/100 	 <p>Technical drawing showing dimensions: 100 (width), 77 (height), 36 (height to top), 3 (height to bottom), 101 (total height), 45 (height to bottom), and 90 (width).</p>
	<p>Elbow, rotary from suspension system CS-3000neXt to tube 48 mm 1014800008 RAL 9006 white-aluminium *</p> <ul style="list-style-type: none"> Aluminium die-casting Rotation angle 300° with stop Weight: 2457 g Connection for equipotential bonding 	 <p>Technical drawing showing dimensions: 28 (width), 42 (height), and 100 (width).</p>

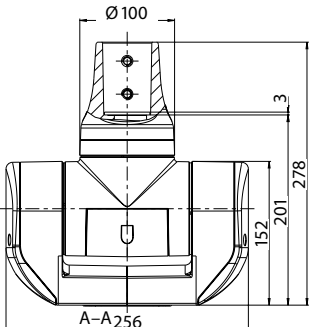
* Die-cast aluminium components standard in RAL 9006 (white-aluminium)

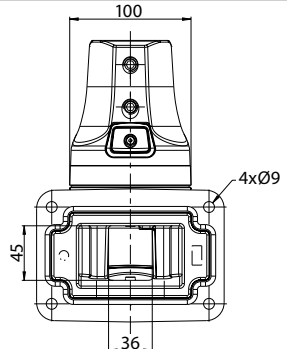

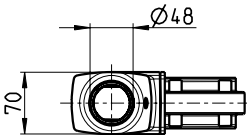
SUSPENSION SYSTEM CS-480 B.fleX

	Article	Dimensions in mm														
	<p>Turn/tilt coupling 101480005 RAL 9006 white-aluminium *</p> <ul style="list-style-type: none"> Aluminium die-casting Rotation angle 300° with stop Weight: 5284 g Connection for equipotential bonding Tilt moment 27 Nm 															
	<p>Wall joint S 101480011 RAL 9006 white-aluminium *</p> <ul style="list-style-type: none"> Aluminium die-casting Rotation angle 300° with stop Weight: 2634 g Connection for equipotential bonding 															
	<p>Elbow, reducer from suspension system CS-3000 to tube 48 mm 1015300197 RAL 9006 white-aluminium *</p> <ul style="list-style-type: none"> Reducer elbow for the square tube to 48 mm round tube Aluminium die-casting Weight: 1920 g 															
	<p>Suspension tube Ø 48 mm</p> <ul style="list-style-type: none"> Galvanised steel Maximum cable diameter Ø 40 mm Lengths can be selected 	<table border="1"> <thead> <tr> <th data-bbox="1109 1444 1300 1478">Article number</th> <th data-bbox="1316 1444 1476 1478">Length in mm</th> </tr> </thead> <tbody> <tr> <td data-bbox="1109 1500 1252 1534">9521244000</td> <td data-bbox="1324 1500 1372 1534">250</td> </tr> <tr> <td data-bbox="1109 1541 1252 1574">9521245000</td> <td data-bbox="1324 1541 1372 1574">500</td> </tr> <tr> <td data-bbox="1109 1581 1252 1615">9521246000</td> <td data-bbox="1324 1581 1372 1615">750</td> </tr> <tr> <td data-bbox="1109 1621 1252 1655">9521247000</td> <td data-bbox="1324 1621 1372 1655">1000</td> </tr> <tr> <td data-bbox="1109 1662 1252 1695">9521248000</td> <td data-bbox="1324 1662 1372 1695">1250</td> </tr> <tr> <td data-bbox="1109 1702 1252 1736">9521249000</td> <td data-bbox="1324 1702 1372 1736">1500</td> </tr> </tbody> </table>	Article number	Length in mm	9521244000	250	9521245000	500	9521246000	750	9521247000	1000	9521248000	1250	9521249000	1500
Article number	Length in mm															
9521244000	250															
9521245000	500															
9521246000	750															
9521247000	1000															
9521248000	1250															
9521249000	1500															

* Die-cast aluminium components standard in RAL 9006 (white-aluminium)

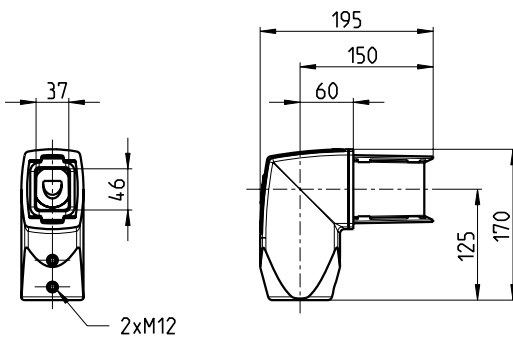
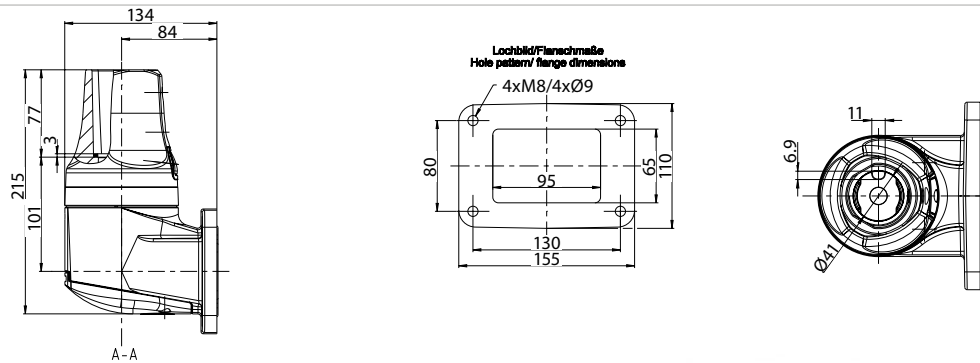
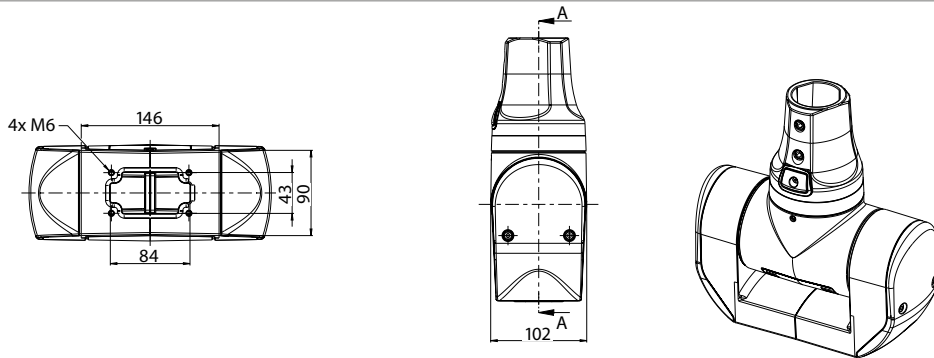

Designation	Weight in kg
-------------	--------------

ST-Rohr 48x4x250	1.085
ST-Rohr 48x4x500	2.169
ST-Rohr 48x4x750	3.254
ST-Rohr 48x4x1000	4.338
ST-Rohr 48x4x1250	5.423
ST-Rohr 48x4x1500	6.507

Connection from above or below with coupling and reduction elbow

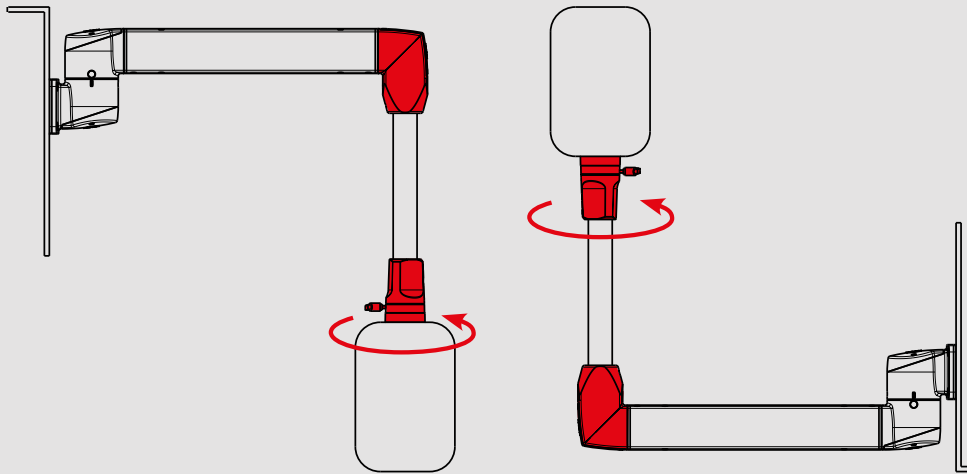

Connection from below or above with coupling and stand base

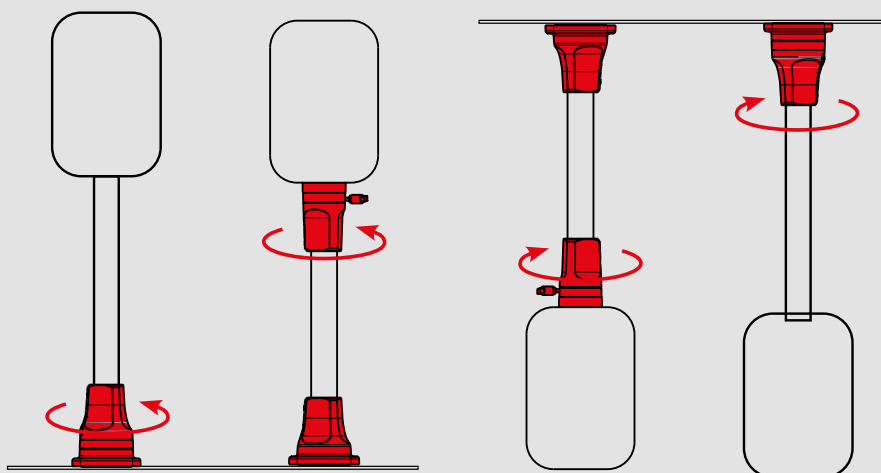

Machine connection with rotatable elbow

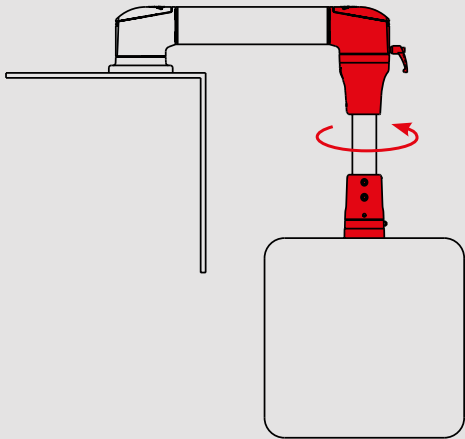

Connection from below with stand base and panel coupling S

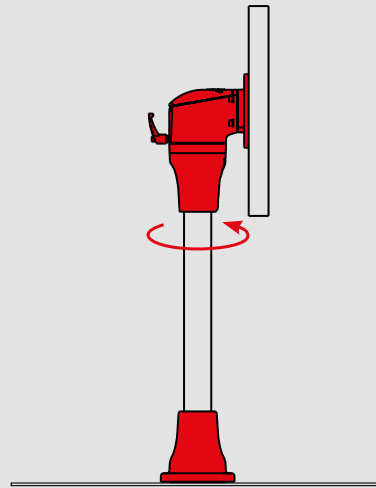

Wall connection with wall joint S

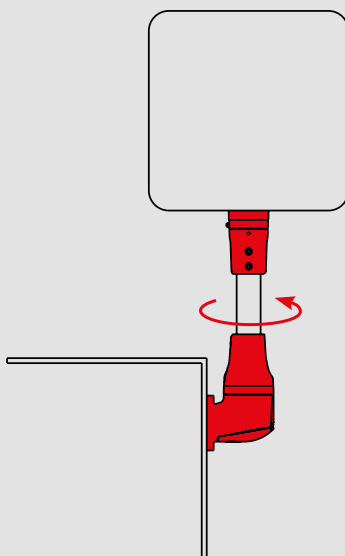

Stainless steel suspension system CS-480 NR

For special hygiene requirements, such as in the food and pharmaceutical industries, the flexible BERNSTEIN CS-480 NR suspension system made of stainless steel offers exactly the right components.

Thanks to its wide range of variants, the CS 480 NR offers great flexibility. You have the choice between a combination of customised bent tubes or bent tubes with support system components available from stock.

System features

- Installation openings on the bearing components with horizontal outlet
- Simple assembly due to the clamping of the support tubes
- Load capacity 400 N on 1 m
- Protection class IP66/NEMA 4X
- Material 1.4305
- Factory preset torque



Load diagram

Static load of the CS-480 NR

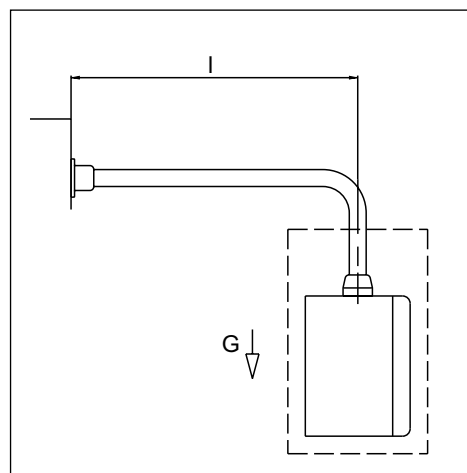
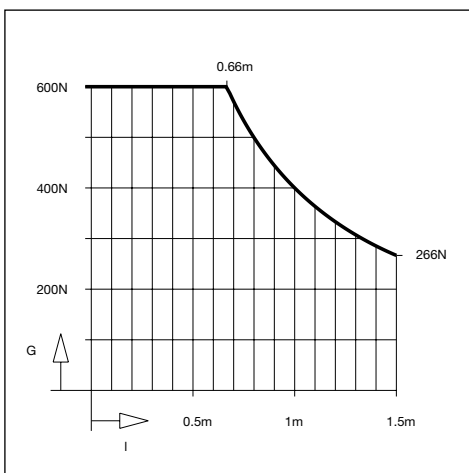

The load capacity of the CS-480 NR suspension system programme is shown in the diagram. In the case of higher loads, approval must be requested separately.

The system length l of the following illustration refers to the length specification of the diagram.

Application examples



**CS-480 NR suspension system
with wall connection**

- Wall joint S
- 48 round tube bent
- IPC with round tube connection



**CS-480 NR suspension system
with stand base**

- IPC with round tube connection
- 48 round tube bent
- Rotatable stand base



**CS-480 NR suspension system
connection e.g. to control cabinet**

- IPC with round tube connection /
Coupling on stainless steel enclosure

SUSPENSION SYSTEM CS-480 NR

Enclosure machining for coupling assembly

The following drawing shows the geometry of the coupling hole pattern for enclosure machining..

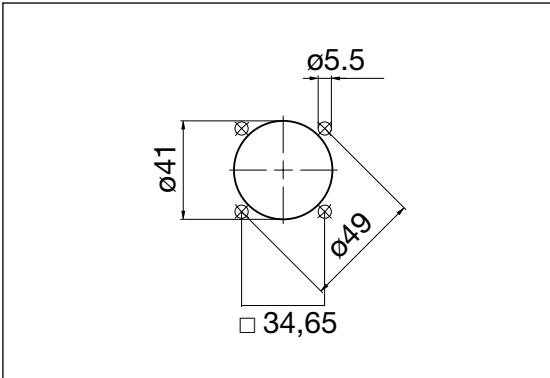

Materials and surfaces

Stainless steel support tubes	1.4301
Stainless steel components	1.4305
Bearing	POM
O-rings	NBR

Customised support tubes

Curved support tubes for the BERNSTEIN CS-480 NR suspension system are also available in different variants according to the customer's wishes. To order customised tubes, simply indicate the shape (e.g. straight, L-, U- or Z-bent) and the dimensions. Minimum quantity for bent tube: 5 pieces

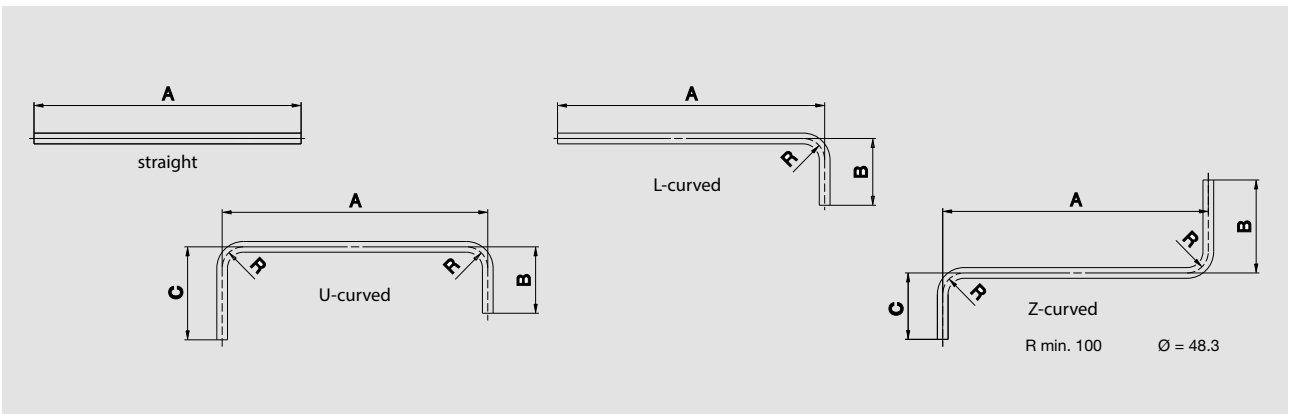

Note:

Dimension B and C at least 220 mm; dimension A in version U and Z at least 320 mm

System combinations

The high flexibility in the configuration of the suspension system is illustrated by the following selection:

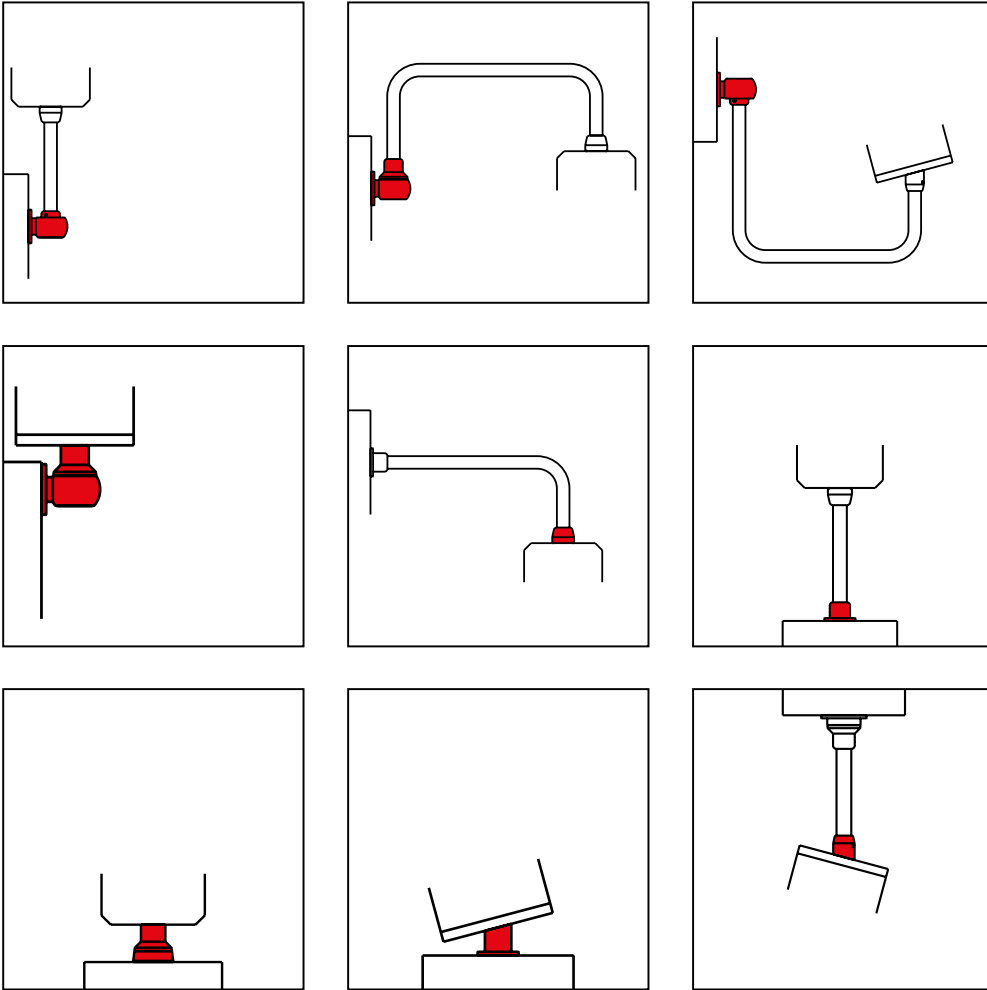







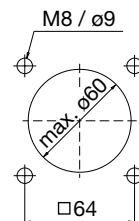
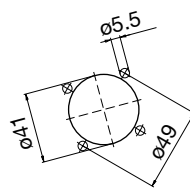
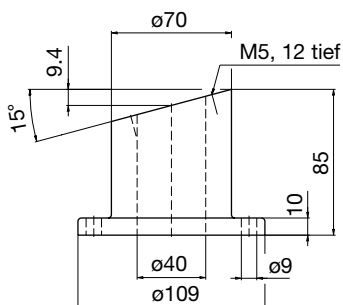
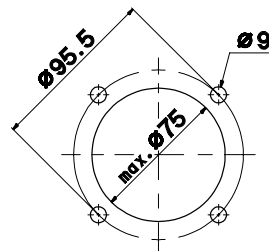
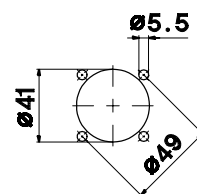
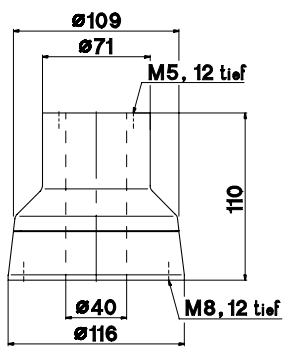
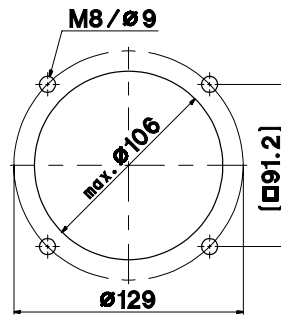
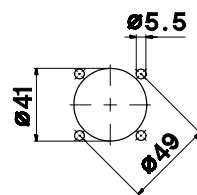
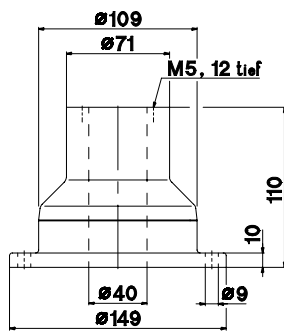
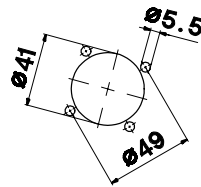
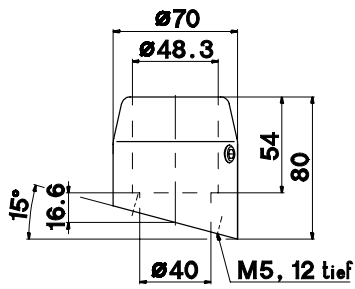
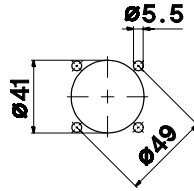
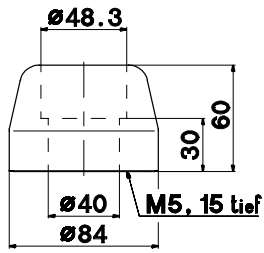

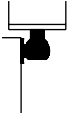

SUSPENSION SYSTEM CS-480 NR

	Article	Application example
	<p>Coupling (for attaching enclosure) 1013050100 Stainless steel</p> <ul style="list-style-type: none"> • Flange coupling for fastening enclosures • Rotation angle 340° with stop limit • Pre-set torque • Maintenance free bearings • Complete with seals and fixing material • Weight: 1400 g 	
	<p>Tilt coupling (for attaching enclosure) 1013050300 Stainless steel</p> <ul style="list-style-type: none"> • Flange coupling rigid with 15° inclination for fastening of enclosures • Complete with seals and fixing material • Weight: 1000 g 	
	<p>Rotary base coupling, external mounting 1013050700 Stainless steel</p> <ul style="list-style-type: none"> • For direct attachment of enclosures to machines or to the floor • Rotation angle 340° with stop limit • Pre-set torque • Maintenance free bearings • Complete with seals and fixing material • Weight: 4500 g 	
	<p>Rotary base coupling, internal mounting 1013050800 Stainless steel</p> <ul style="list-style-type: none"> • For direct attachment of enclosures to machines or to the floor • Rotation angle 340° with stop limit • Pre-set torque • Maintenance free bearings • Complete with seals and fixing material • Weight: 4100 g 	
	<p>Stand base tilt coupling 1013050400 Stainless steel</p> <ul style="list-style-type: none"> • Tilt coupling rigid with 15° tilt for direct attachment of enclosures to horizontal surfaces • Complete with seals and fixing material • Weight: 1900 g 	

Dimensions in mm

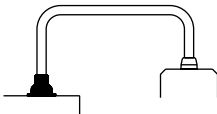

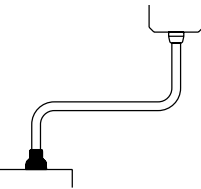
SUSPENSION SYSTEM CS-480 NR

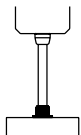
	Article	Application example
	<p>Wall joint S 1013050900 Stainless steel</p> <ul style="list-style-type: none"> • Wall joint with vertical outlet for mounting on vertical surfaces • Cover for easy cable mounting • Rotation angle 340° with stop limit • Pre-set torque • Maintenance free bearings • Complete with seals • Weight: 7300 g 	
	<p>Wall coupling S 1013051000 Stainless steel</p> <ul style="list-style-type: none"> • Rotary wall coupling for directly mounting on vertical machine surfaces • Rotation angle 340° with stop limit • Cover for easy cable mounting • Pre-set torque • Maintenance free bearings • Complete with seals and fixing material • Weight: 7300 g 	
	<p>Wall bracket S 1013051100 Stainless steel</p> <ul style="list-style-type: none"> • Wall bracket with vertical outlet for mounting on vertical surfaces • Cover for easy cable mounting • Complete with seals • Weight: 7700 g 	
	<p>Rotatable stand base, external mounting 1013050500 Stainless steel</p> <ul style="list-style-type: none"> • For mounting on machines or floors • Rotation angle 340° with stop limit • Pre-set torque • Maintenance free bearings • Complete with seals • Weight: 4200 g 	
	<p>Rotatable stand base, internal mounting 1013050600 Stainless steel</p> <ul style="list-style-type: none"> • For mounting on machines or floors • Rotation angle 340° with stop limit • Pre-set torque • Maintenance free bearings • Complete with seals • Weight: 3800 g 	
	<p>Stand base / wall flange 1013050200 Stainless steel</p> <ul style="list-style-type: none"> • For mounting on horizontal and vertical surfaces • Complete with seals • Weight: 1400 g 	

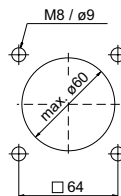
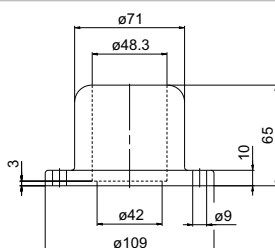
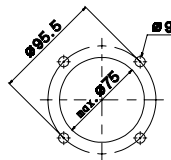
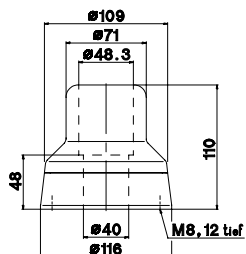
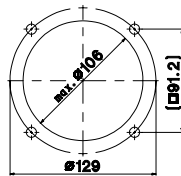
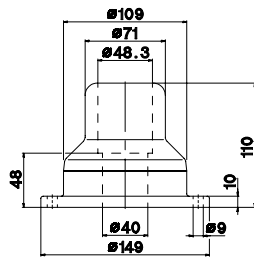
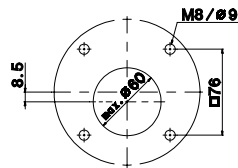
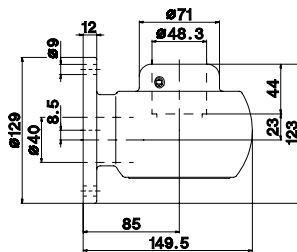
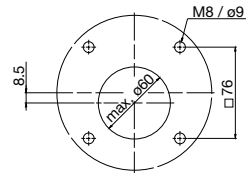
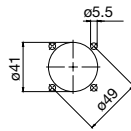
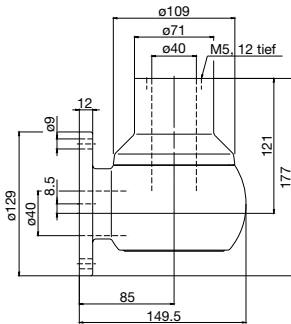
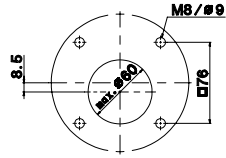
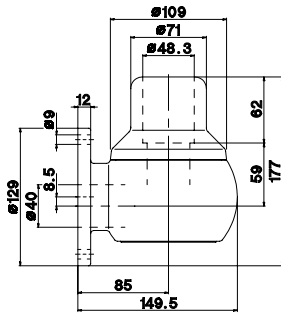
Dimensions in mm

More comfort. More safety.

Compliance with occupational health and safety laws and thus the maintenance of the health of employees is becoming more and more important.

Individual and ergonomically designed operator stations are an integral part of today's working conditions. Simple and uncomplicated height adjustment of the visualization unit is possible with the **ergo.fleX** from BERNSTEIN.

Man and machine in focus

With the **ergo.fleX**, BERNSTEIN AG simplifies the operation and monitoring of machines and systems.

Without complex adjustments, the visualisation height can be adjusted to the ergonomically correct position in just a few steps to meet personal requirements at the operator station.

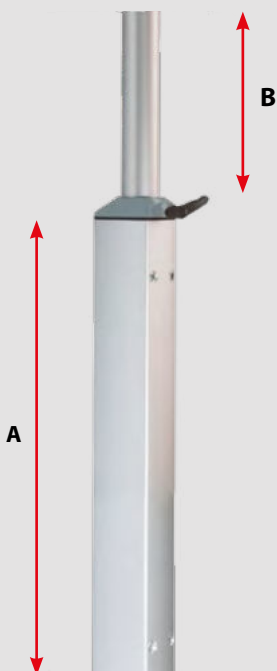
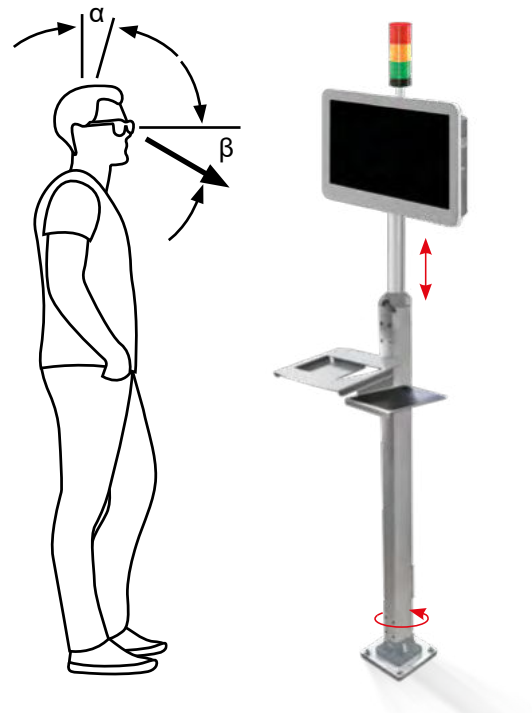

Alignment of the visualization height to different sized operators.

- 1000 mm long CS-3000 aluminium tube (A)
- 1000 mm version: wall mounting
- 1000 mm version: free standing
- 1000 mm version: pendent
- Height adjustment: 250 mm (B)
- Locking in any position possible with the clamping lever

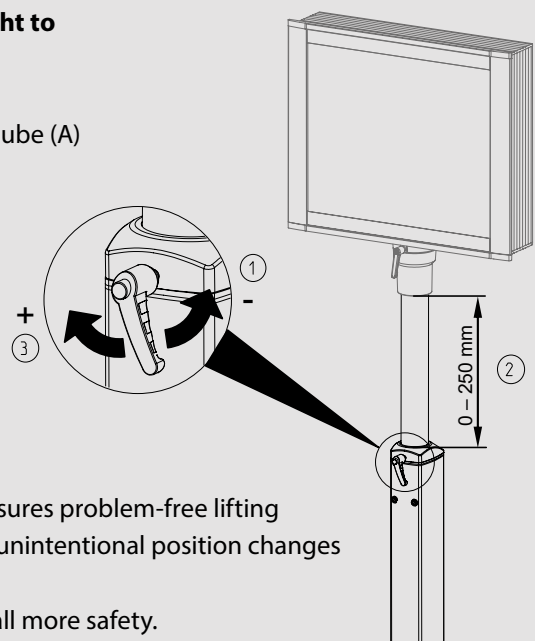

The integrated gas pressure spring ensures problem-free lifting of the visualisation unit and prevents unintentional position changes after releasing the clamping lever. This means more comfort and above all more safety.

Cable management

Internal cable management

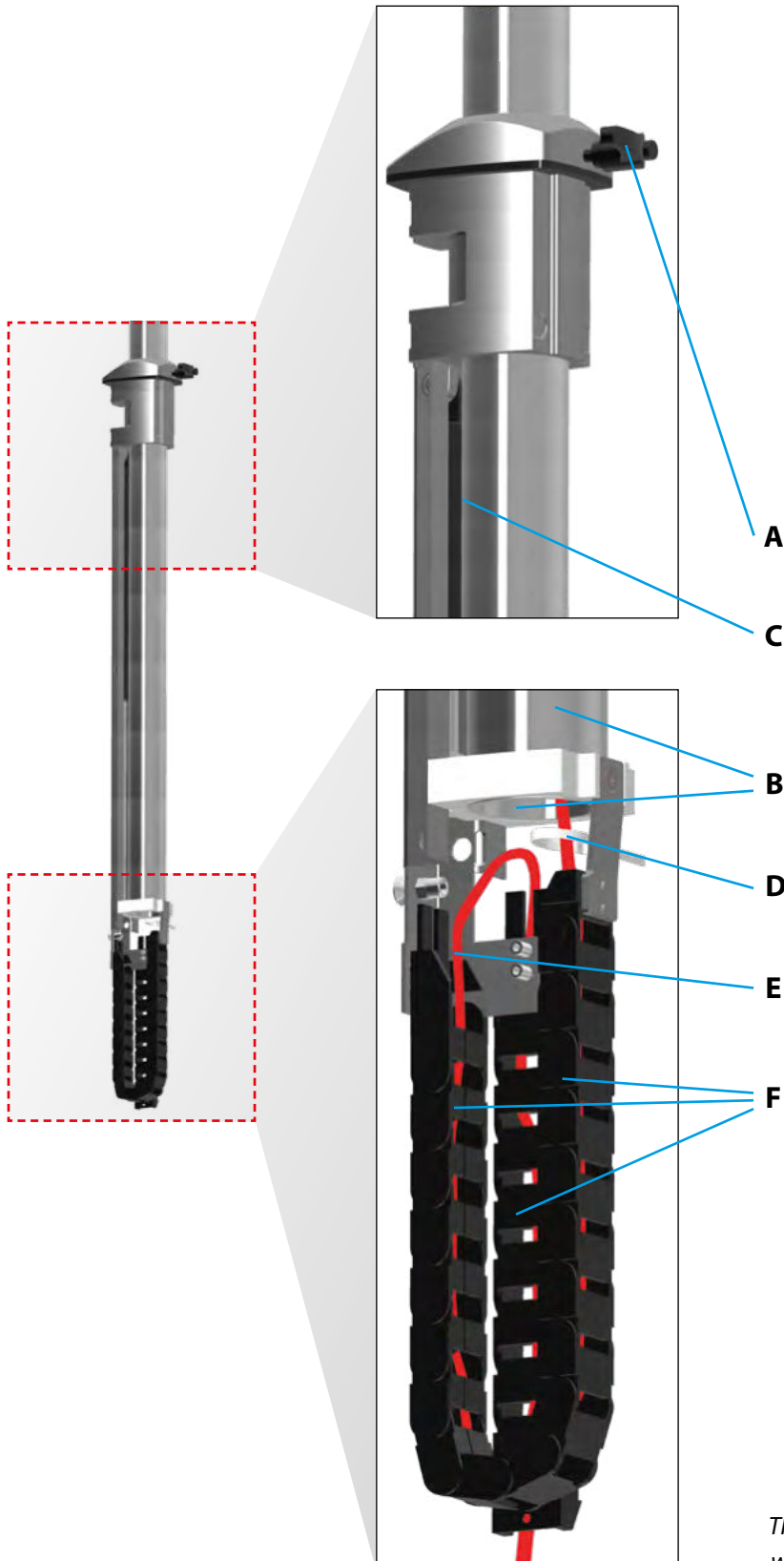

- The cable conduit (B) and the gas pressure spring (C) are separate from each other.
- The gas pressure spring counteracts the independent and uncontrolled adjustment of the adapted control unit after releasing the clamping lever (A) and also reduces the force required for the desired height adjustment.
- The energy chains (F) attached below (standing version) the gas pressure spring serve as safe and reliable cable routing in the moving part of the ergo.flex. They prevent damage to the cables. It is also possible to integrate strain relief (D) of the cables (E) in this area.

The internal cable management was shown without the CS-3000 tube!

The advantages again at a glance:

- The variable stroke (250 mm) allows an optimum visualisation height
- Gas pressure spring assists in lifting and prevents uncontrolled adjustment after releasing the clamping lever
- Internal cable routing using an energy chain
- Easy integration to the CS-3000 suspension system

Materials:

- Galvanized steel tube CS-480 B.fleX
- Anodised aluminium tubes CS-3000
- Connection components made of die-cast aluminium
- POM bearing
- Neoprene seals
- protection class IP 54
- Energy chain PA

The maximum load of the system is 30 kg



Selection criteria gas pressure spring

Total weight and ambient temperature influence selection

The total weight is calculated for the:

- Enclosure
- Installed equipment
- Coupling components

Different gas springs, depending on the area of use

Ambient temperature	100 N (8.7 kg)	150 N (14 kg)	200 N (19.4 kg)	300 N (30.0 kg)
40 °C	100 N (8.3 kg)	150 N (13.5 kg)	200 N (18.7 kg)	300 N (29.0 kg)
30 °C	100 N (8.0 kg)	150 N (13 kg)	200 N (18.0 kg)	300 N (28.0 kg)
20 °C				

Strength of the gas pressure spring [N] (maximum weight load [kg])

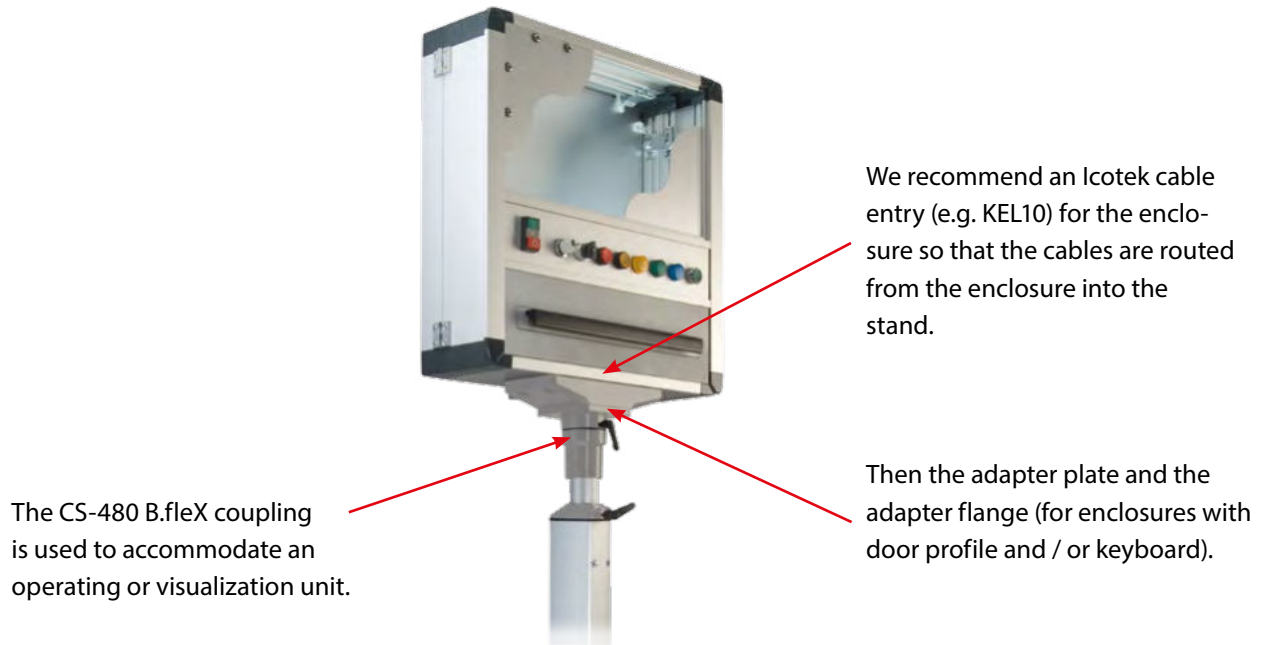

Accessories for system integration



Our solutions



Ordering data ergo.flex

Figure	Article
	ergo.flex 1000/100 suspended 1015300295 <ul style="list-style-type: none">• Gas pressure spring force [N]: 100• Colour: RAL 9006 (standard)
	ergo.flex 1000/150 suspended 1015300292 <ul style="list-style-type: none">• Gas pressure spring force [N]: 150• Colour: RAL 9006 (standard)
	ergo.flex 1000/200 suspended 1015300293 <ul style="list-style-type: none">• Gas pressure spring force [N]: 200• Colour: RAL 9006 (standard)
	ergo.flex 1000/300 suspended 1015300294 <ul style="list-style-type: none">• Gas pressure spring force [N]: 300• Colour: RAL 9006 (standard)
	ergo.flex 1000/100 upright 1015300296 <ul style="list-style-type: none">• Gas pressure spring force [N]: 100• Colour: RAL 9006 (standard)
	ergo.flex 1000/150 upright 1015300297 <ul style="list-style-type: none">• Gas pressure spring force [N]: 150• Colour: RAL 9006 (standard)
	ergo.flex 1000/200 upright 1015300298 <ul style="list-style-type: none">• Gas pressure spring force [N]: 200• Colour: RAL 9006 (standard)
	ergo.flex 1000/300 upright 1015300299 <ul style="list-style-type: none">• Gas pressure spring force [N]: 300• Colour: RAL 9006 (standard)

Notes



Diagrams. Sketches. Ideas.

A large grid of small dots, intended for sketching or drawing. The dots are arranged in a regular, repeating pattern across the page.

ergo.slide

Height adjustment of individual components –
within seconds

Spontaneous and intuitive – the **ergo.slide** height adjustment makes changing the working posture a natural part of everyday working life. The easier, faster and more comfortable an adjustment is, the more frequently it is used. With the **ergo.slide** from BERNSTEIN, the simple and uncomplicated height adjustment of individual working components, such as the keyboard, is possible in just a matter of seconds. It meets all the requirements of independent height adjustments of individual components of an operator station – for example to different body postures and sizes and subjective requirements.

An accessory for suspension systems:

CS-3000 — CS-480 B.flex — CS-3000_{next}

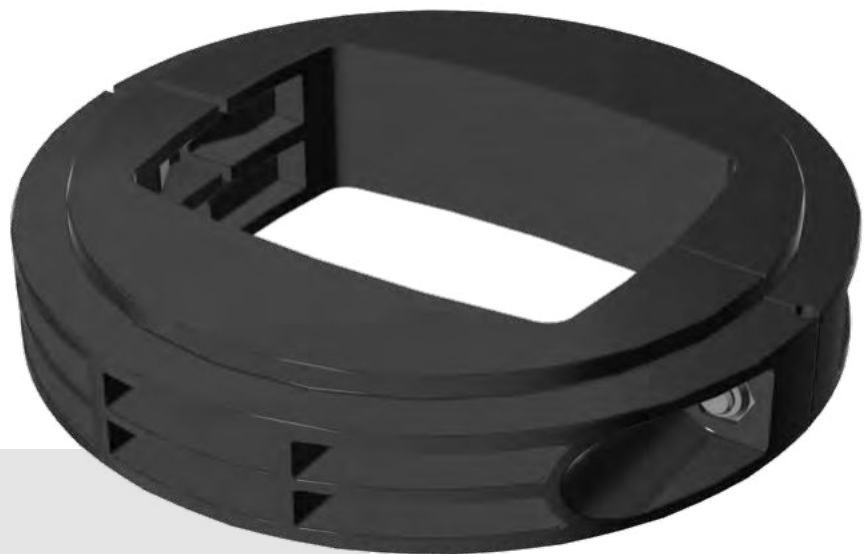

Technical data

- Maximum load: 25 kg
- Maximum number of height adjustments: 3500
- Easy adjustment by loosening the adjusting screw
- Safe and secure addition of system components
- Leaves no marks when gliding on the tube
- The storage components are held in a fixed position, but rotatable
- Can be used with a suspension system and a free standing column

How does the ergo.slide work?

Two plastic injection moulded parts (common parts) are connected and fixed by a screw.

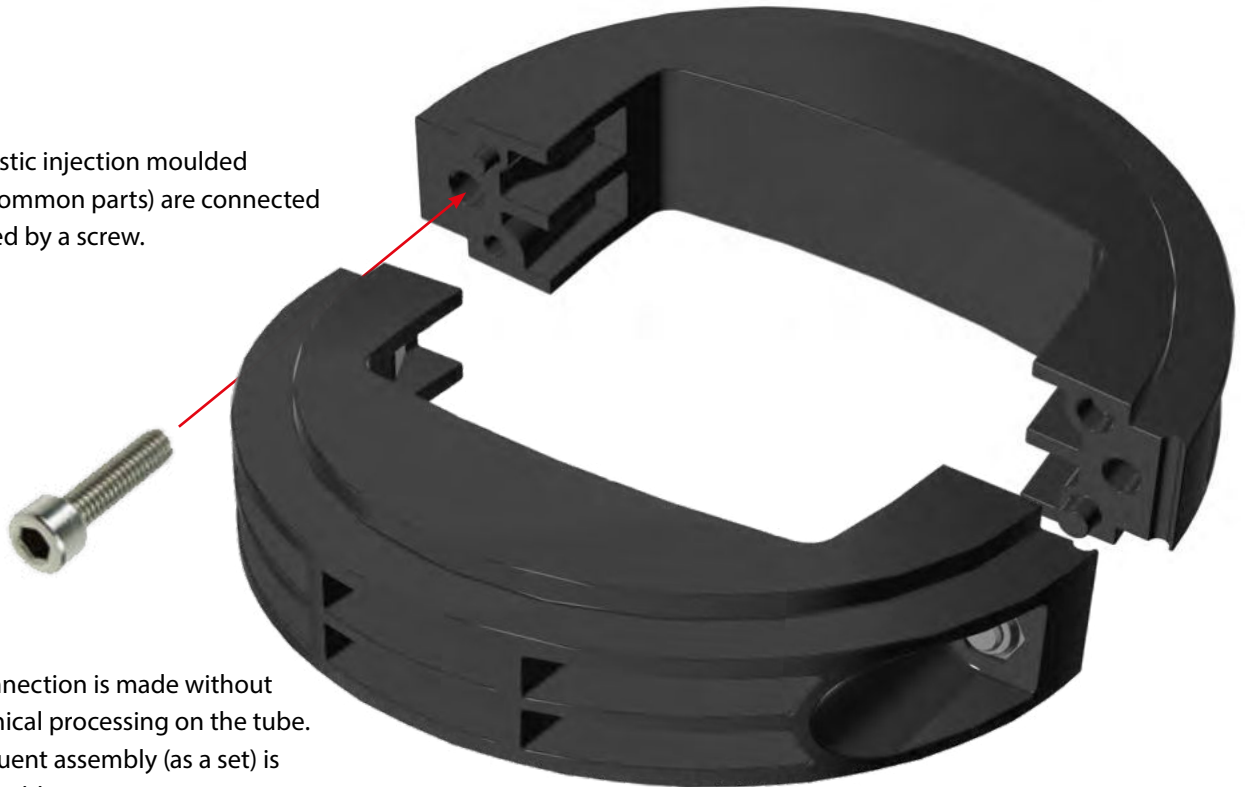

The connection is made without mechanical processing on the tube. Subsequent assembly (as a set) is also possible.

Thanks to modern health and safety laws, rigid control elements and uniform workplaces, which demand forced and unnatural work postures, are a relic of the past.

Adjustment

The height of the **ergo.slide** can be adjusted by loosening the screw.

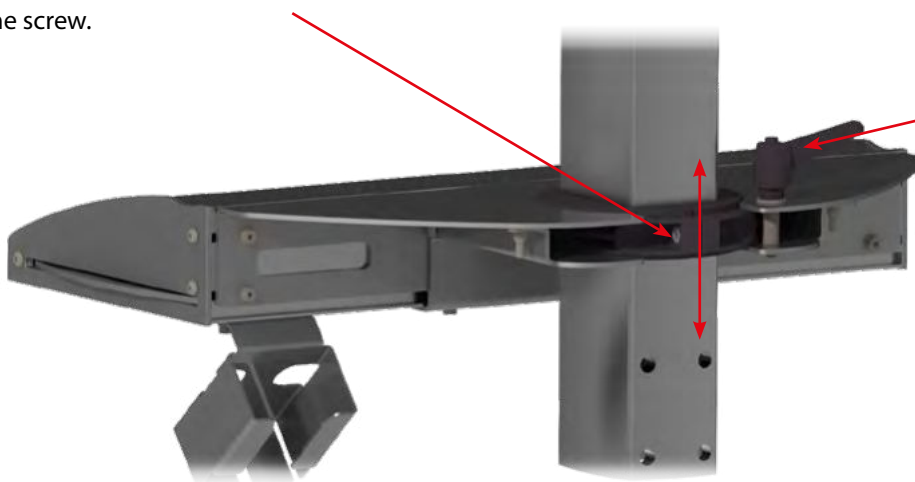

Rotating the keyboard shelf is also possible after loosening the clamping levers.

Applications

Simple connection incl. height adjustment of keyboard shelves

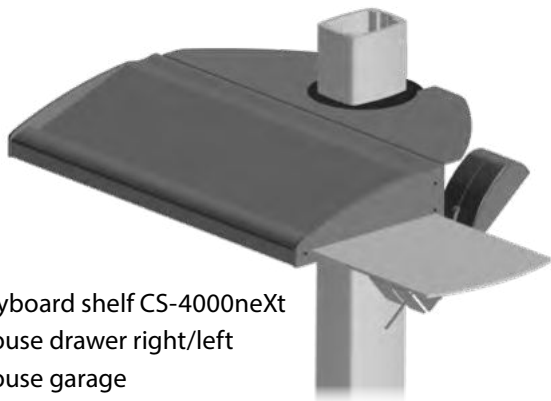

- Keyboard shelf CS-4000neXt
- Mouse drawer right/left
- Mouse garage

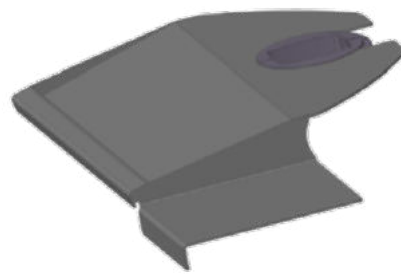

- Simple sheet metal keyboardshelf
- Incl. fixed mouse tray

Wall connection

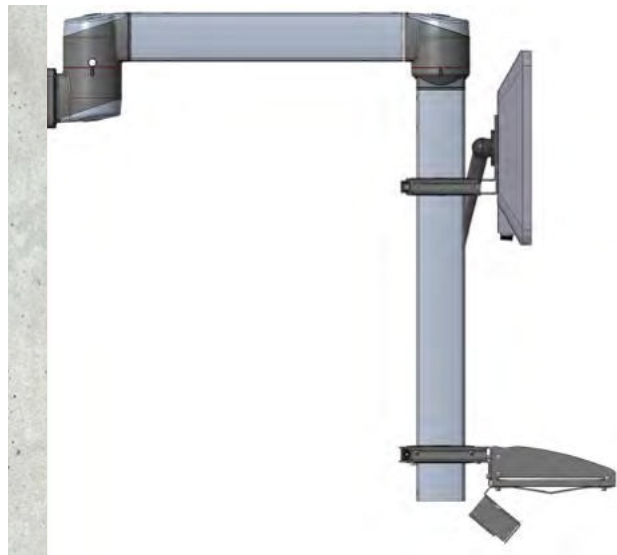
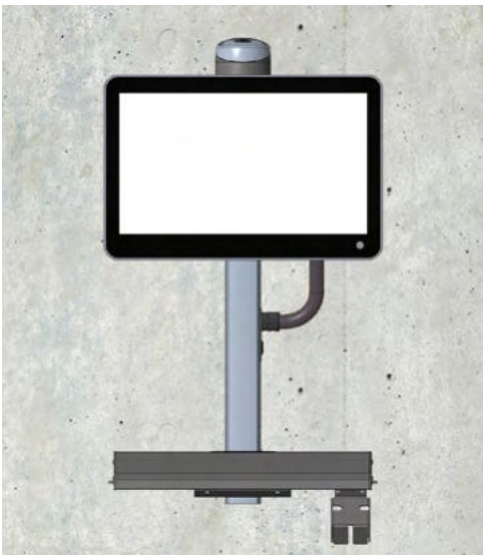

- Wall joint W rotatable CS-3000
- Elbow rotatable CS-3000
- CS-3000 tube incl. cover
- IPC Holder with **ergo.slide**
- **ergo.slide** Keyboard shelf

Wall connection



- Wall joint S CS-3000
- Tube CS-3000
- Incl. cover for tube covering
- IPC Holder with **ergo.slide**

Base cabinet connection



- Fixed base CS-3000
- CS-3000 tube
- Incl. cover for tube covering
- IPC-Holder with **ergo.slide**

Applications

Machine connection

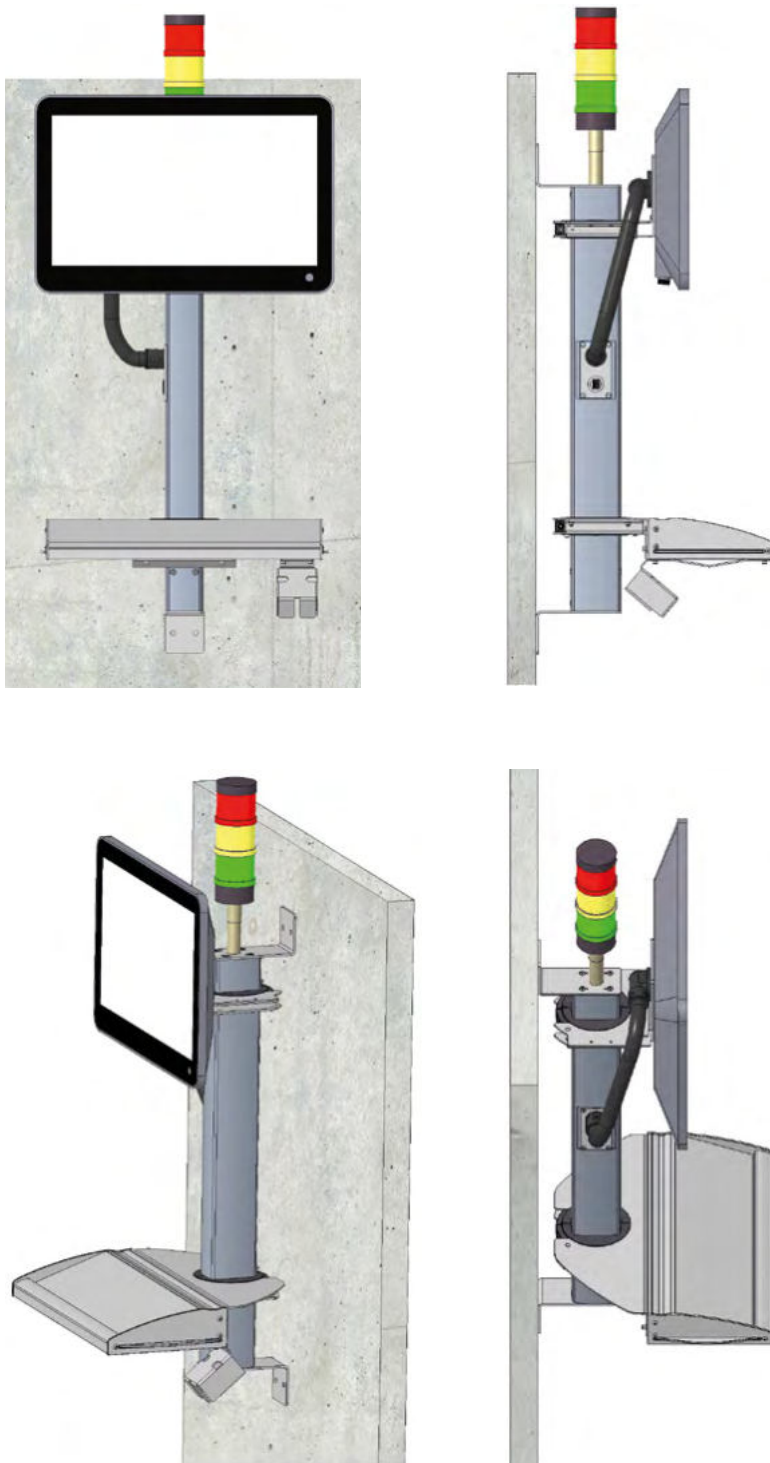

- Tube CS-3000
- Clamping elbow for mounting on the machine
- IPC Holder with **ergo.slide**
- **ergo.slide** keyboard shelf

Ordering data ergo.slide

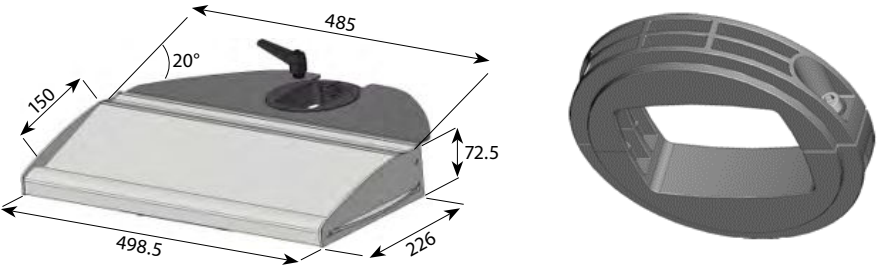
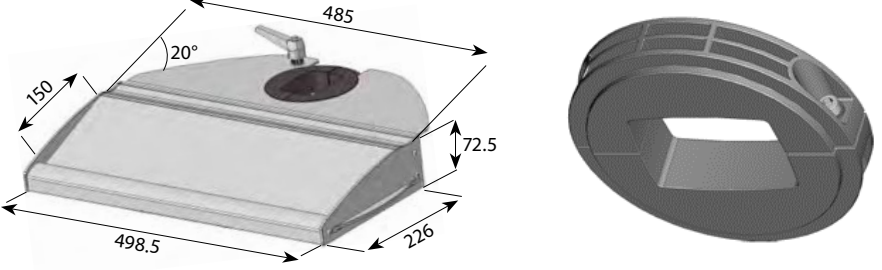
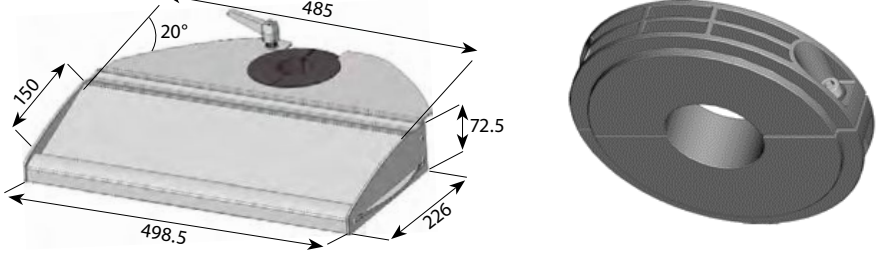
Article	Figure (data in mm)
<p>ergo.slide CS-3000 Keyboard shelf with mousepad right/left 9806000109</p>	 <p>Keyboard shelf CS-4000 neXt</p> <ul style="list-style-type: none"> • Material: powdered steel • Weight: 8.23 kg • Colour: RAL 9006 (standard) • Mousepad extendable to the left or right • Keyboard support surface: 485 x 150 mm (width x depth) <p>ergo.slide CS-3000</p> <ul style="list-style-type: none"> • Material: polyamide • Weight: 0.235 kg • Colour: black
<p>ergo.slide CS-3000neXt Keyboard shelf with mousepad right/left 9806000110</p>	 <p>Keyboard shelf CS-4000 neXt</p> <ul style="list-style-type: none"> • Material: powdered steel • Weight: 8.23 kg • Colour: RAL 9006 (standard) • Mousepad extendable to the left or right • Keyboard support surface: 485 x 150 mm (width x depth) <p>ergo.slide CS-3000 neXt</p> <ul style="list-style-type: none"> • Material: polyamide • Weight: 0.295 kg • Colour: black
<p>ergo.slide CS-480 B.flex Keyboard shelf with mousepad right/left 9806000111</p>	 <p>Keyboard shelf CS-4000 neXt</p> <ul style="list-style-type: none"> • Material: powdered steel • Weight: 8.23 kg • Colour: RAL 9006 (standard) • Mousepad extendable to the left or right • Keyboard support surface: 485 x 150 mm (width x depth) <p>ergo.slide CS-480 B.flex</p> <ul style="list-style-type: none"> • Material: polyamide • Weight: 0.35 kg • Colour: black

QUICK ADJUSTMENT: ergo.slide

Ordering data ergo.slide

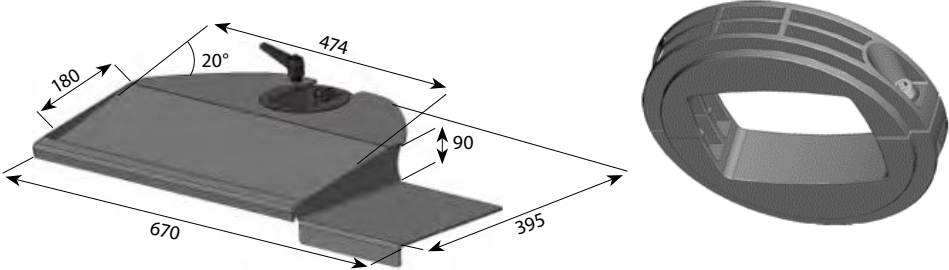
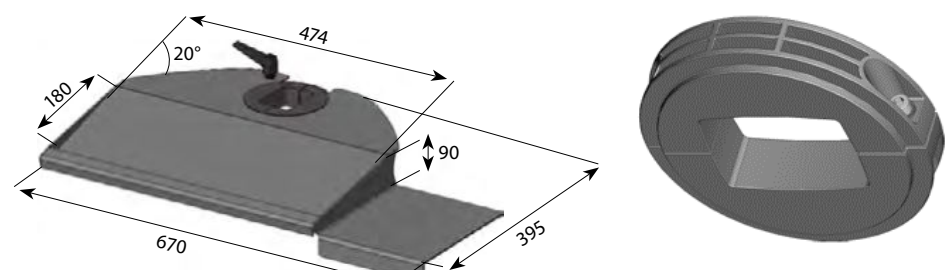
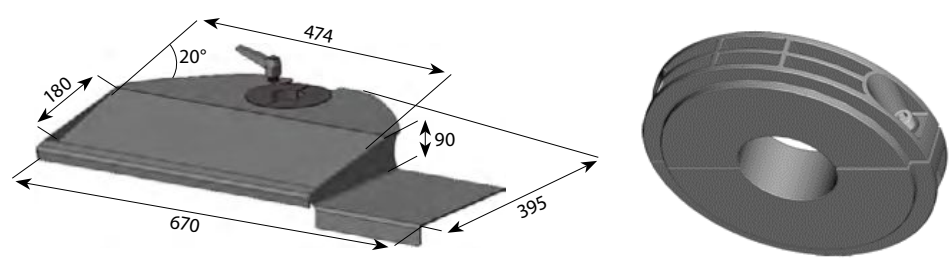
Article	Figure (data in mm)
<p>ergo.slide CS-3000 Keyboard shelf with mousepad right 9806000112</p> <p>Sheet metal keyboard shelf</p> <ul style="list-style-type: none">• Material: powdered steel• Weight: 6.575 kg• Colour: RAL 9006 (standard)• Mousepad fixed• Keyboard support surface: 474 x 180 mm (width x depth) <p>ergo.slide CS-3000</p> <ul style="list-style-type: none">• Material: polyamide• Weight: 0.235 kg• Colour: black	
<p>ergo.slide CS-3000next Keyboard shelf with mousepad right 9806000113</p> <p>Sheet metal keyboard shelf</p> <ul style="list-style-type: none">• Material: powdered steel• Weight: 6.575 kg• Colour: RAL 9006 (standard)• Mousepad fixed• Keyboard support surface: 474 x 180 mm (width x depth) <p>ergo.slide CS-3000 neXt</p> <ul style="list-style-type: none">• Material: polyamide• Weight: 0.295 kg• Colour: black	
<p>ergo.slide CS-480 B.flex Keyboard shelf with mousepad right 9806000114</p> <p>Sheet metal keyboard shelf</p> <ul style="list-style-type: none">• Material: powdered steel• Weight: 6.575 kg• Colour: RAL 9006 (standard)• Mousepad fixed• Keyboard support surface: 474 x 180 mm (width x depth) <p>ergo.slide CS-480 B.flex</p> <ul style="list-style-type: none">• Material: polyamide• Weight: 0.35 kg• Colour: black	

Article	Figure
---------	--------

ergo.slide CS-3000
VESA holder

9806000138

VESA holder (75/100)

- Central passage Ø50
- Material: powdered steel
- Weight: 1.69 kg
- Colour: RAL 9006 (standard)

ergo.slide CS-3000

- Material: polyamide
- Weight: 0.235 kg
- Colour: black



ergo.slide CS-3000neXt
VESA holder

9806000139

VESA holder (75/100)

- Central passage Ø50
- Material: powdered steel
- Weight: 1.69 kg
- Colour: RAL 9006 (standard)

ergo.slide CS-3000 neXt

- Material: polyamide
- Weight: 0.295 kg
- Colour: black

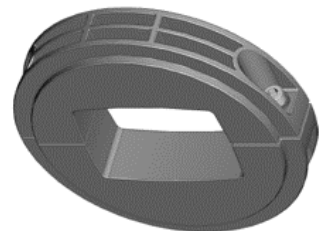

ergo.slide CS-480 B.flex
VESA holder

9806000140

VESA holder (75/100)

- Central passage Ø50
- Material: powdered steel
- Weight: 1.69 kg
- Colour: RAL 9006 (standard)

ergo.slide CS-480 B.flex

- Material: polyamide
- Weight: 0.35 kg
- Colour: black

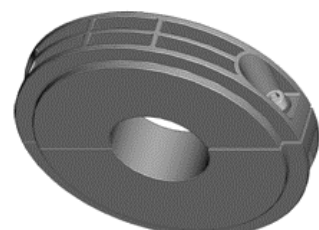

Accessories

Mouse garage



9806000141

- Material: powdered steel
- Weight: 0.293 kg
- Colour: RAL 9006 (standard)
- For mice with max. 68 x 43 mm (WxH)

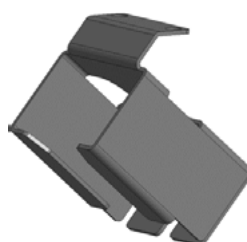
Note: The mouse garage can be mounted on all current keyboard shelf variants.



Ordering data ergo.slide Accessories

Article	Figure
<p>End cap for support tube CS-3000 9806000147</p> <ul style="list-style-type: none">• Material: aluminium• Weight: 0.115 kg• Colour: RAL 9006 (standard)	
<p>End cap for support tube CS-3000neXt 9806000148</p> <ul style="list-style-type: none">• Material: aluminium• Weight: 0.083 kg• Colour: RAL 9006 (standard)	
<p>End cap for support tube CS-480 B.flex 9806000149</p> <ul style="list-style-type: none">• Material: aluminium• Weight: 0.043 kg• Colour: RAL 9006 (standard)	
<p>Wall mounting set for support tube CS-3000 9806000150</p> <ul style="list-style-type: none">• Material: steel• Weight: 1.277 kg• Colour: RAL 9006 (standard)	
<p>Wall mounting set for support tube CS-3000neXt 9806000151</p> <ul style="list-style-type: none">• Material: steel• Weight: 1.025 kg• Colour: RAL 9006 (standard)	
<p>Wall mounting set for support tube CS-480 B.flex 9806000152</p> <ul style="list-style-type: none">• Material: steel• Weight: 1.267 kg• Colour: RAL 9006 (standard)	
<p>Handle screw 9806000184</p> <ul style="list-style-type: none">• Material: galvanised steel and plastic PA6• Weight: 0.120 kg• Colour of handle: black <p>Note: This replaces the screw for clamping the ergo.slide. This enables tool-free operation.</p>	

Notes



Diagrams. Sketches. Ideas.

A large grid of small dots, intended for sketching or writing notes.

flex.base

The flexible stand solution for your operating stations

The **flex.base** offers a pedestal solution for operator stations to give flexible positions, manoeuvrability, and yet also stability in production. Expandable with a wide range of accessories such as castors, adjustable feet or additional weights, the stand provides both mobility and optional static positioning for all BERNSTEIN suspension systems. This ergonomically thought-out, convertible and high-quality operator station component is an excellent solution for optimising mobility and flexibility in the field of production technology.

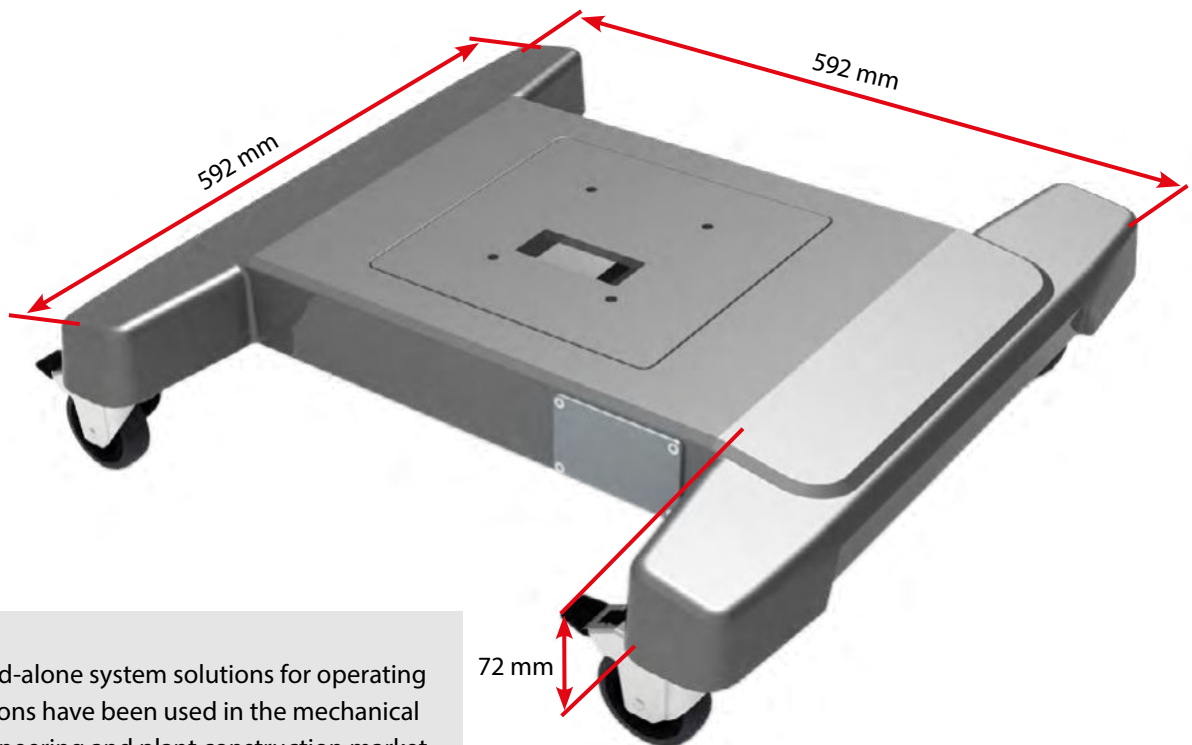

Stand-alone system solutions for operating stations have been used in the mechanical engineering and plant construction market for years.

The requirements range from fixed, stable solutions to height-adjustable variants and mobile systems. Such products are rounded off with optional accessories for floor mounting or rollable design.

- Free-standing pedestal for adaptation of all BERNSTEIN suspension systems
- Alternatively screwed to the floor
- Optionally with castors

Technical data

- Weight stand base: approx. 11.1 kg
- Weight adapter plate: ca. 3.6 kg
- Material stand base: die-cast aluminium
- Material adapter plate: powdered steel
- Integrated earthing screws
- Generous space for cable routing
- Rear cover plate; for own processing

Technical construction

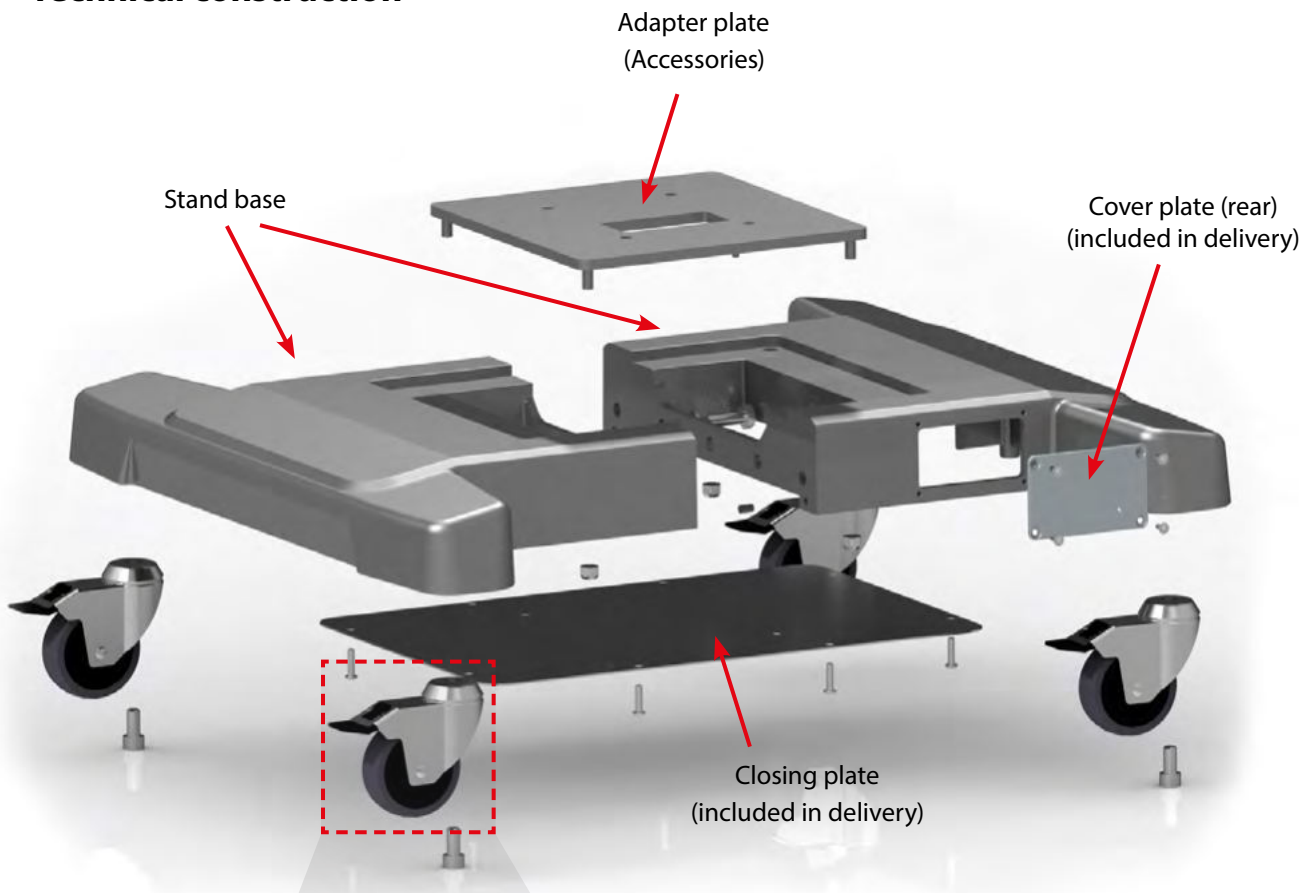

**Accessories: Castors
or adjustable feet**

Variant for floor mounting



Rear view

Cable entry

A cover plate is located on the rear side as cable entry.
Optionally, the cable entry can also be made with Icotek.

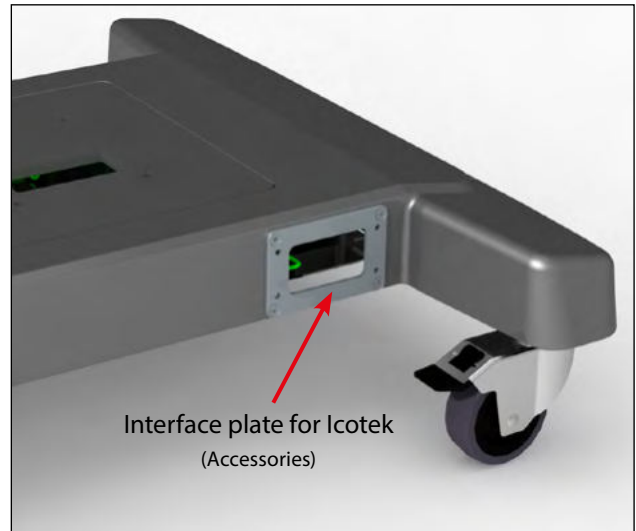
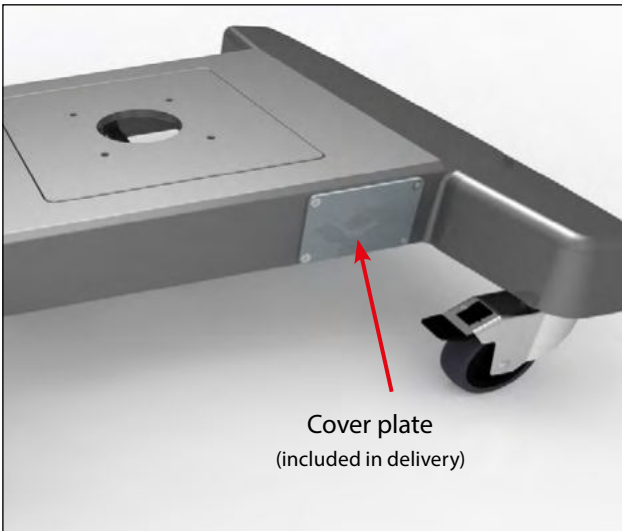

For own processing of cable glands or cable entry systems.

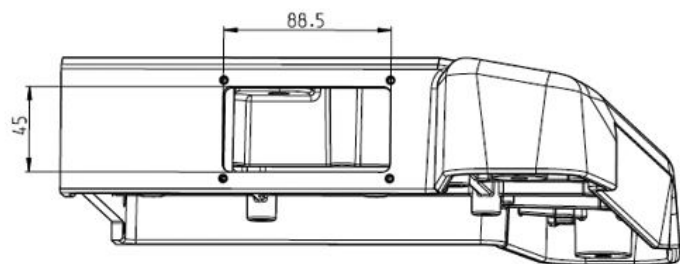
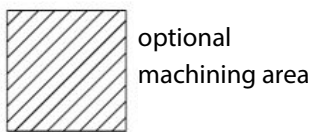
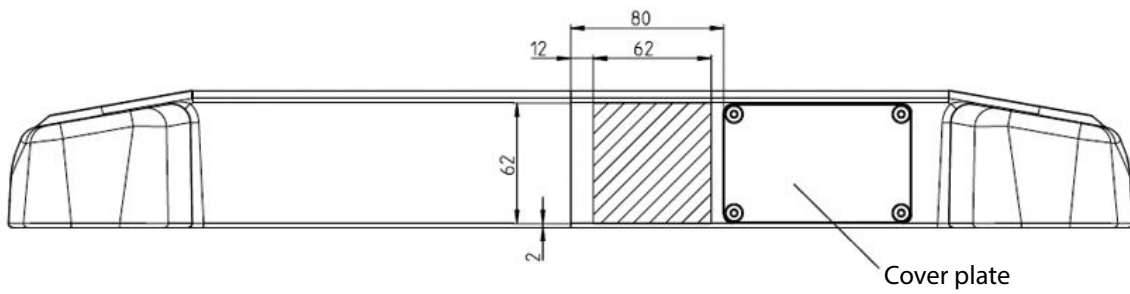

Earthing / Cable management

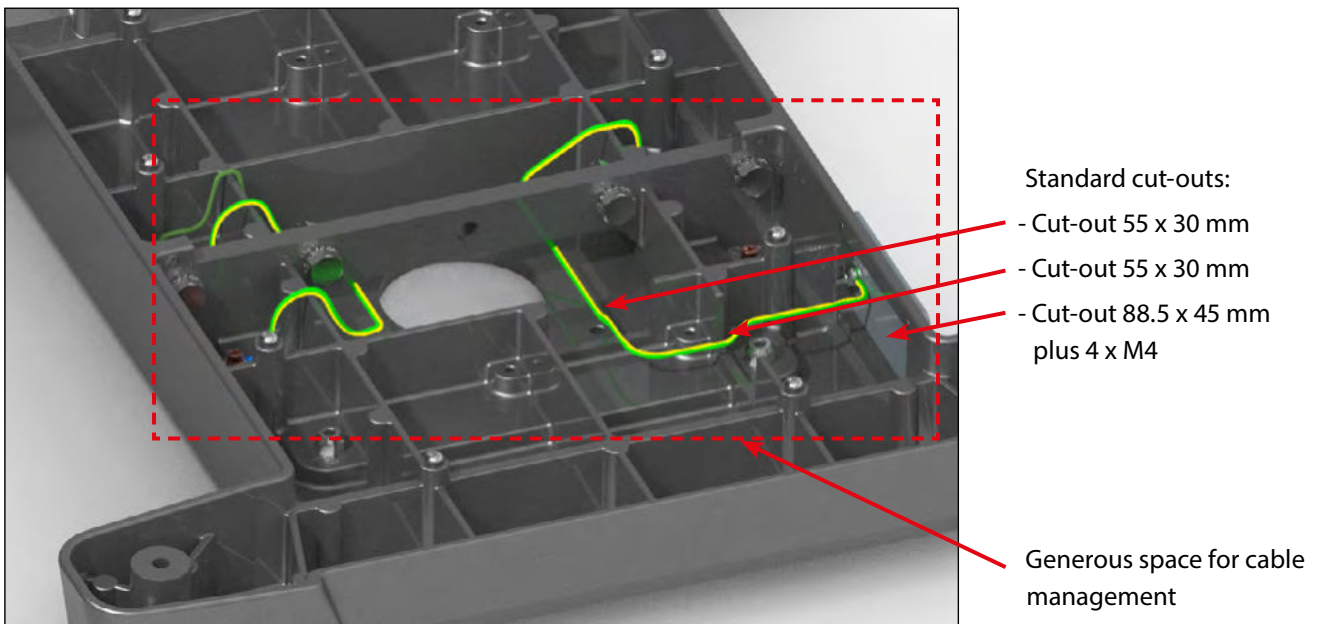

The stand base **flexi**.base offers generous space for cable management.
An integrated earthing concept is also part of the new stand base.

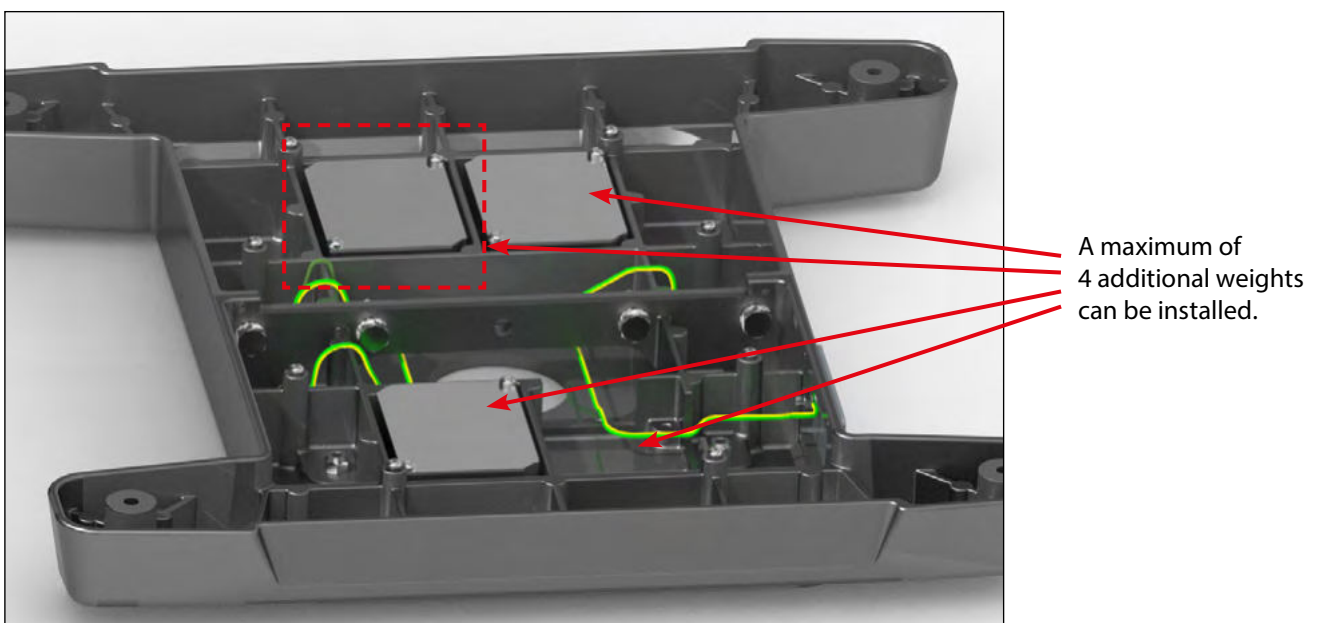

Additional weight

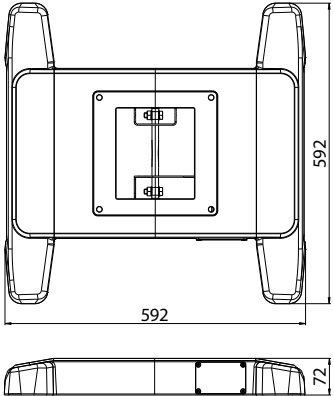

Ordering data flex_obase

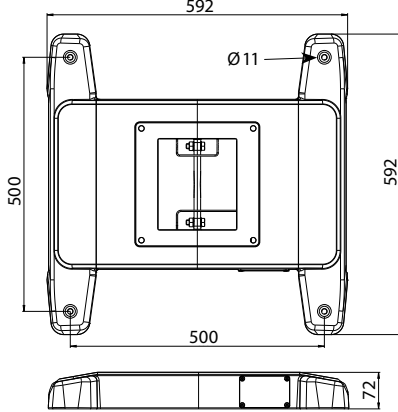
Article	Figure	Dimension drawing (data in mm)
<p>flex_obase stand base 101652200 RAL 9006 white-aluminium</p> <ul style="list-style-type: none"> • Material: die-cast aluminium • Weight: 11.1 kg 		
<p>flex_obase stand base for floor mounting 1016562200 RAL 9006 white-aluminium</p> <ul style="list-style-type: none"> • Material: die-cast aluminium • Weight: 11.1 kg 		

flex_obase Accessories

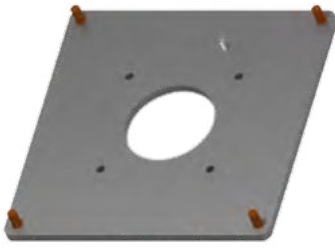
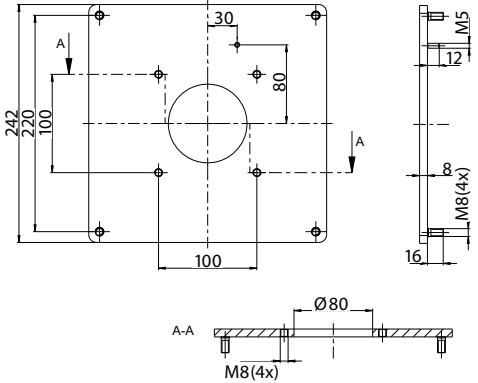
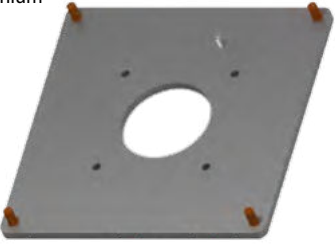
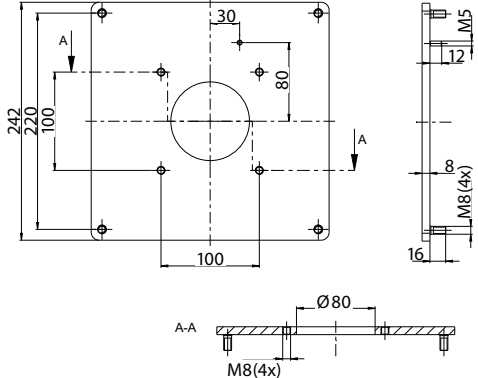
<p>Adapter plate for CS-480 B.flex stand base, fixed 9806000101 RAL 9006 white-aluminium</p> <ul style="list-style-type: none"> • Material: powdered steel • Weight: 3.6 kg 		
<p>Adapter plate for CS-3000 neXt stand base 9806000101 RAL 9006 white-aluminium</p> <ul style="list-style-type: none"> • Material: powdered steel • Weight: 3.6 kg 		

Article	Figure	Dimension drawing (data in mm)
---------	--------	--------------------------------

Adapter plate for CS-3000 stand base

9806000101 RAL 9006 white-aluminium

- Material: powdered steel
- Weight: 3.6 kg

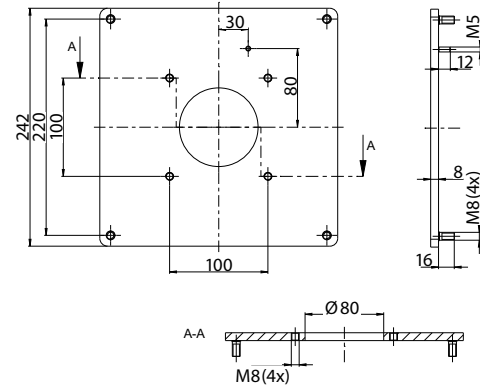
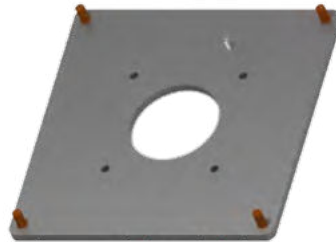

Adapter plate for CS-4000 neXt stand base, fixed

9806000098 RAL 9006 white-aluminium

- Material: powdered steel
- Weight: 3.6 kg

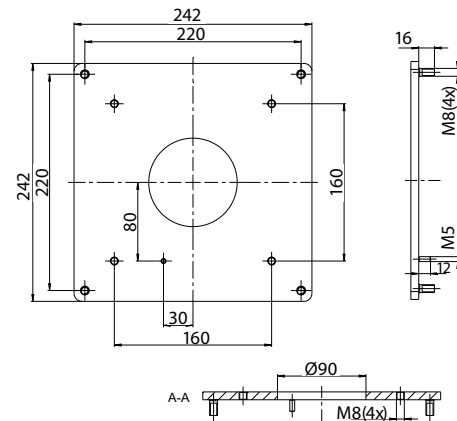
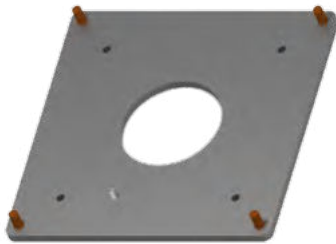

Adapter plate for CS-4000 neXt Column profile

9806000099 RAL 9006 white-aluminium

- Material: powdered steel
- Weight: 3.6 kg

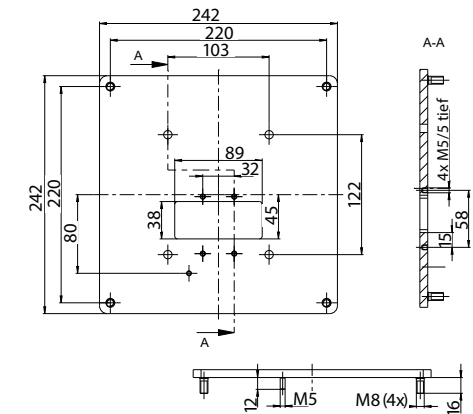
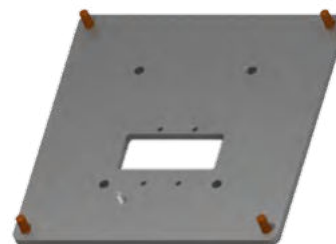

Adapter plate for CS-2000 System 80 Supporting column

9806000098 RAL 9006 white-aluminium

- Material: powdered steel
- Weight: 3.6 kg

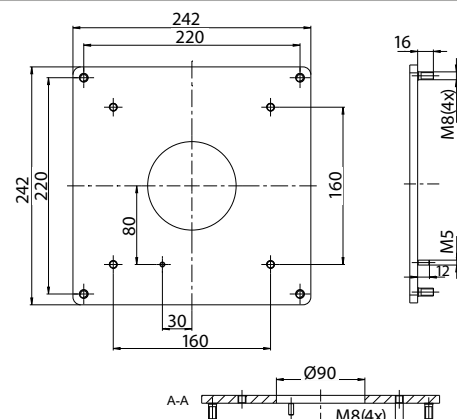
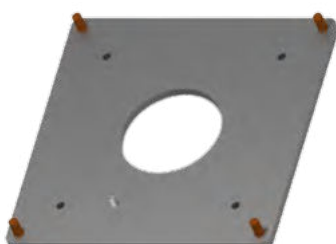

Ordering data flexbase Accessories

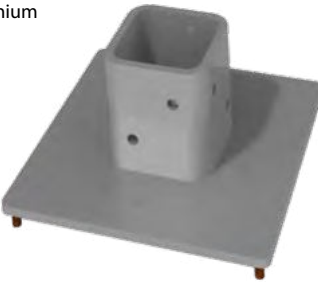
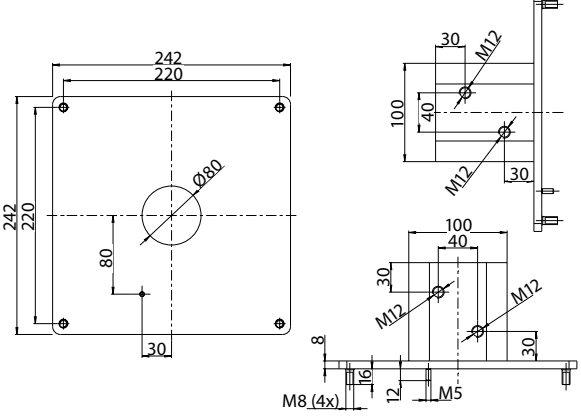
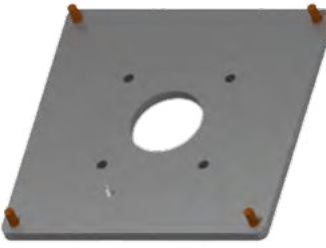
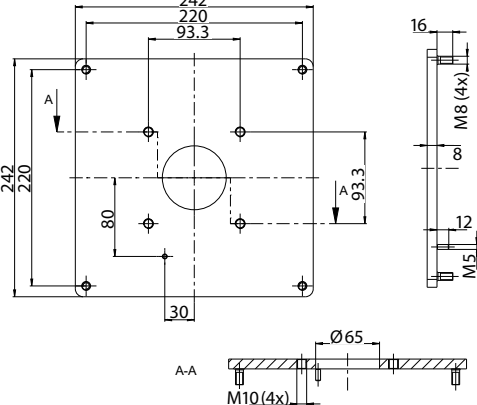
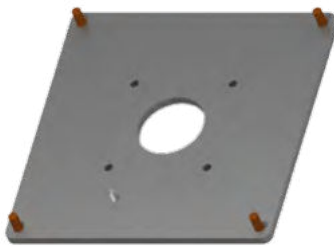
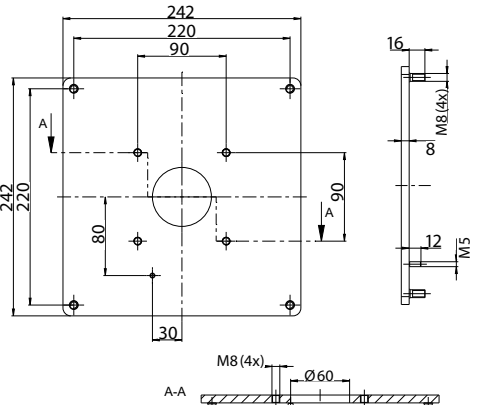
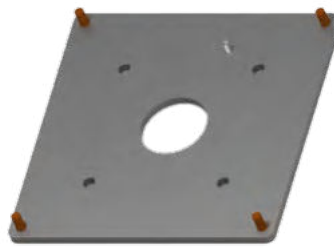
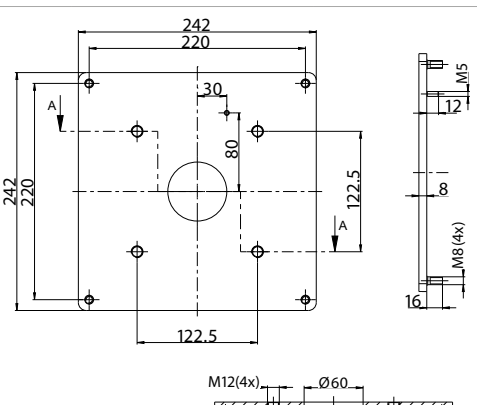
Article	Figure	Dimension drawing (data in mm)
<p>Adapter plate for CS-2000 system 80 for direct connection to the support column tube</p> <p>9806000188 RAL 9006 white-aluminium</p> <ul style="list-style-type: none"> Material: powdered steel Weight: 5,7 kg 		
<p>Adapter plate for CS-2000 system 60 stand base</p> <p>9806000118 RAL 9006 white-aluminium</p> <ul style="list-style-type: none"> Material: powdered steel Weight: 3.6 kg 		
<p>Adapter plate for CS-2000 SL 45/60 stand base</p> <p>9806000119 RAL 9006 white-aluminium</p> <ul style="list-style-type: none"> Material: powdered steel Weight: 3.6 kg 		
<p>Adapter plate for CS-2000 system 80 stand base</p> <p>9806000120 RAL 9006 white-aluminium</p> <ul style="list-style-type: none"> Material: powdered steel Weight: 3.6 kg 		

Article	Figure
---------	--------

Castor set (4 pieces industrial rolls)
9808012800

- Rolls Ø 75 mm
- Load capacity per roll: 50 kg
- Incl. assembly material and instructions

Castor set (4 pieces apparatus rolls)
9808015300

- Rolls Ø 75 mm
- Load capacity per roll: 70 kg
- Incl. assembly material and instructions

Adjustable feet set (4 pieces)
9808012900

- Height adjustable
- Adjustable overall height: 35–45 mm
- Incl. assembly material and instructions
- Load capacity per adjustable foot: 50 kg

flex.base additional weight
9806000145

- Material: steel
- Self-forming screws included
- Weight: 2 kg

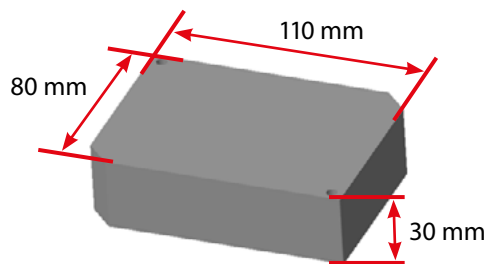
**flex.base interface plate
for Icotek KEL 10**
9806000153

- Material: aluminium

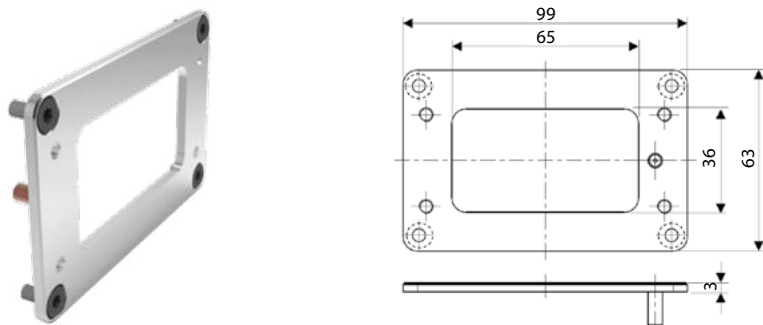

Industrial operator stations

In the industrial sector, robust operator stations are used for a variety of tasks: For visualising processes, for displaying documentation, for the control of work tasks, for production data acquisition and much more. BERNSTEIN AG offers an extensive product portfolio for this area which has almost infinite variation possibilities. In this way, all requirements for industrial operator stations can be easily realised and any customer-specific wishes implemented.

Product features:

- Robust operator stations for industrial use
- Excellent design
- Use of high-quality aluminium materials
- Individual configuration based on an extensive modular system
- Mounting of controllers and command devices in aluminium operating enclosures
- Adapters for combination with Siemens Pro controllers and other IPCs
- Connection of various monitors, e.g. via VESA 75/100 attachment
- Adjustment possibilities by means of a monitor tilt adapter
- Optional addition of various keyboard shelves or drawers to the system
- Installation on fixed stand base or rotating stand base
- Integration of command devices in the pedestal directly or in a control panel



Examples of industrial operator stations



Components and parts

Connection of IPCs on a natural anodised pedestal (IP 65)

By means of various flanges, IPCs from all well-known manufacturers can be easily mounted on the pedestals.

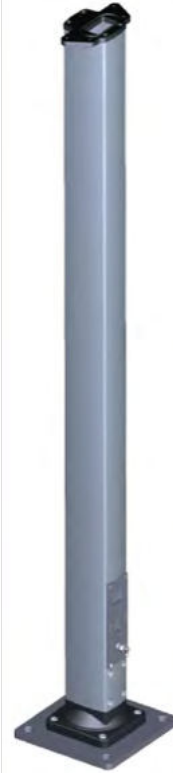

Installing keyboard trays and mouse pads

Depending on the requirements, a variety of standardised keyboard trays are available for the operator stations. Various versions are equipped with mouse pads and garages. They can be fixed or height-adjustable.



Notes

Diagrams. Sketches. Ideas.

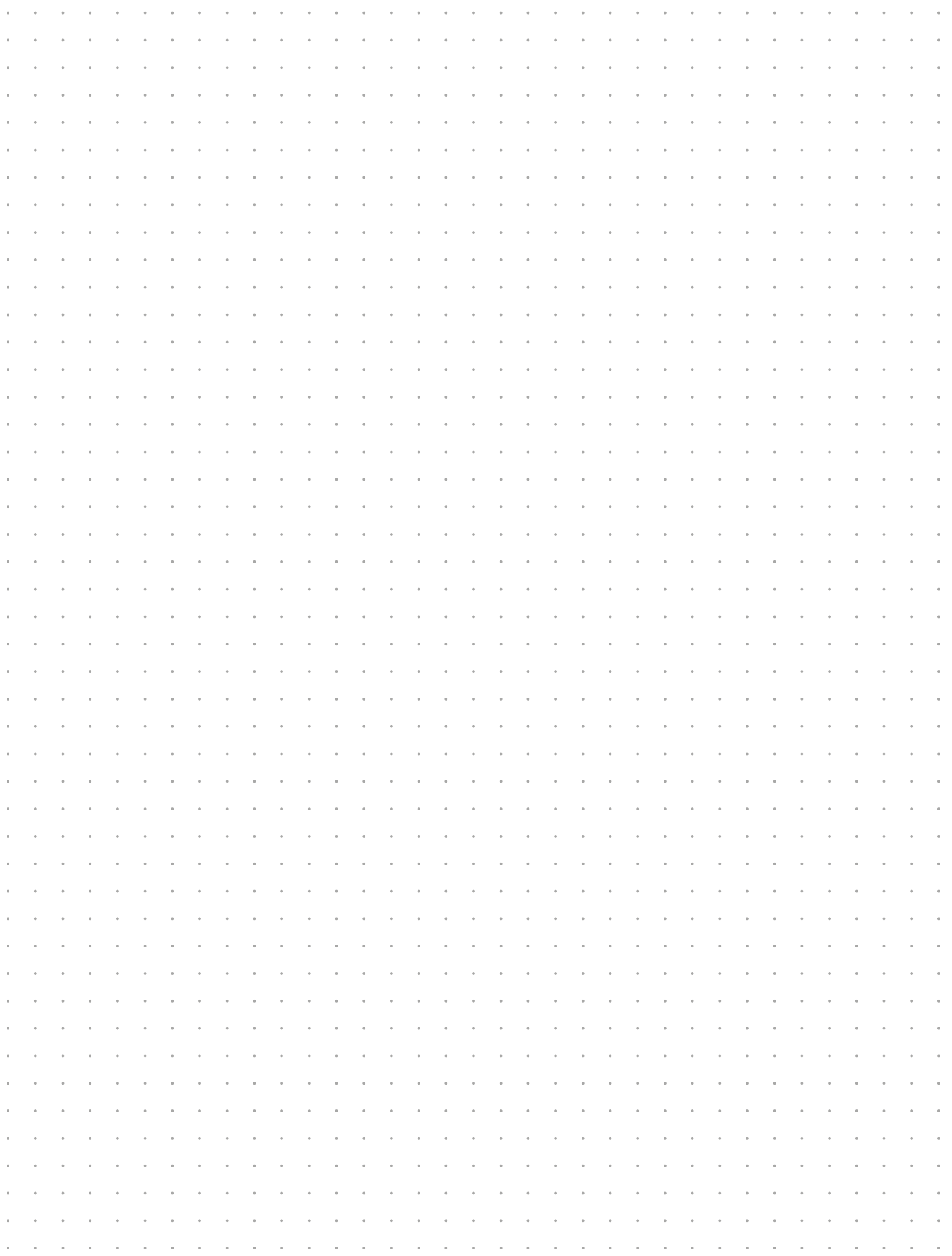



**We make
safety happen.**



**We keep your
visions safe.**

Contact

International Headquarters
BERNSTEIN AG
Hans-Bernstein-Str. 1
32457 Porta Westfalica
Phone +49 571 793-0
info@bernstein.eu
www.bernstein.eu

China
BERNSTEIN Safe Solutions
(Taicang) Co., Ltd.
Phone +86 512 81608180
info@bernstein.asia
www.bernstein.asia

Denmark
BERNSTEIN A/S
Phone +45 7020 0522
info.denmark@bernstein.eu
www.bernstein.dk

Italy
BERNSTEIN S.r.l.
Phone +39 035 4549037
sales@bernstein.it
www.bernstein.it

France
BERNSTEIN S.A.R.L.
Phone +33 1 64 66 32 50
info.france@bernstein.eu
www.bernstein.fr

Austria
BERNSTEIN GmbH
Phone +43 2256 62070-0
office@bernstein.at
www.bernstein.at

United Kingdom
BERNSTEIN Ltd
Phone +44 1922 744999
sales@bernstein-ltd.co.uk
www.bernstein-ltd.co.uk

Switzerland
BERNSTEIN (Schweiz) AG
Phone +41 44 775 71-71
info.schweiz@bernstein.eu
www.bernstein-schweiz.ch