

Technical Data

Float Switch

Standard float switch

Description **MAE-712 FWFL95 0155**

Article number **6814190002**

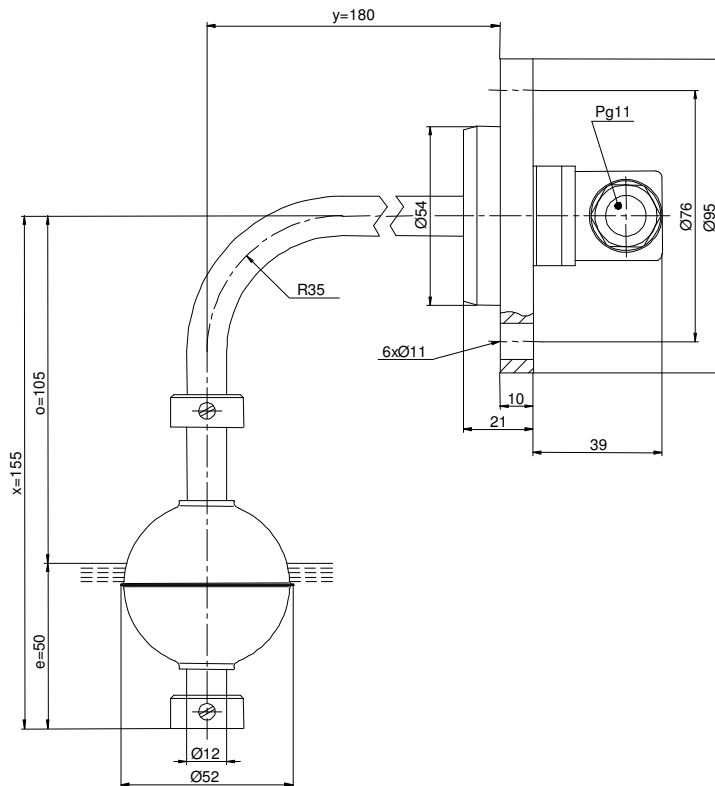

Performance diagram (maximum data)

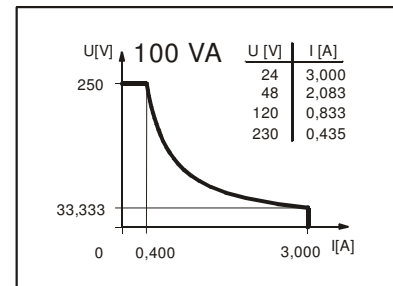

Wiring diagramm (matching to the drawing)

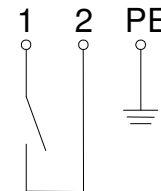

Electrical data

Reed contact	max. switching voltage	250 V
	max. switching current	3,0 A
	max. switching capacity	100 VA
	mechanical life	10 ⁷ to 10 ⁹ switches depending on the load
Switching element		1 normally-open contact, falling level
Direction category		AC-22A and DC-22A acc to DIN VDE 0660 T107
Standard		acc to DIN VDE 0660 T200

Mechanical data

Flange material	X 5 CrNiMoTi 17 12 2 (1.4401)
Switching tube material	X 6 CrNiMoTi 17 12 2 (1.4571)
Float material	X 6 CrNiMoTi 17 12 2 (1.4571)
-density	about 0,65 g/cm ³ ±10%
-depth of immersion	31 mm ±2 mm (to a fluid-density of 1 g/cm ³)
Adjusting ring material	X 6 CrNiMoTi 17 12 2 (1.4571)
Gasket material	NBR
Ambiente air temperature	-5 °C bis +60 °C
Medium temperature	-5 °C bis +60 °C
Connection	plug-in connection acc. to DIN 43650
Protection type	IP 65 acc to DIN VDE 0470 T1
Max. pressure	15 bar

General details

Reproducibility of switching points is ±0,05mm based on the same geometrical conditions as of a switch device.
 The measures of the switching points refer to a fluid-tight of 1 g/cm³.
 The tolerance of the switching points is ±2mm
 Pay attention to the contact protection, when switching inductive loads. Maximum data must not be exceeded!

Subject to change without notice.