

# Foot-switch Series F2

Description **F2-SU1ZCA2ZDR/SU1ZCA2ZDR**

Article number **6162000828**

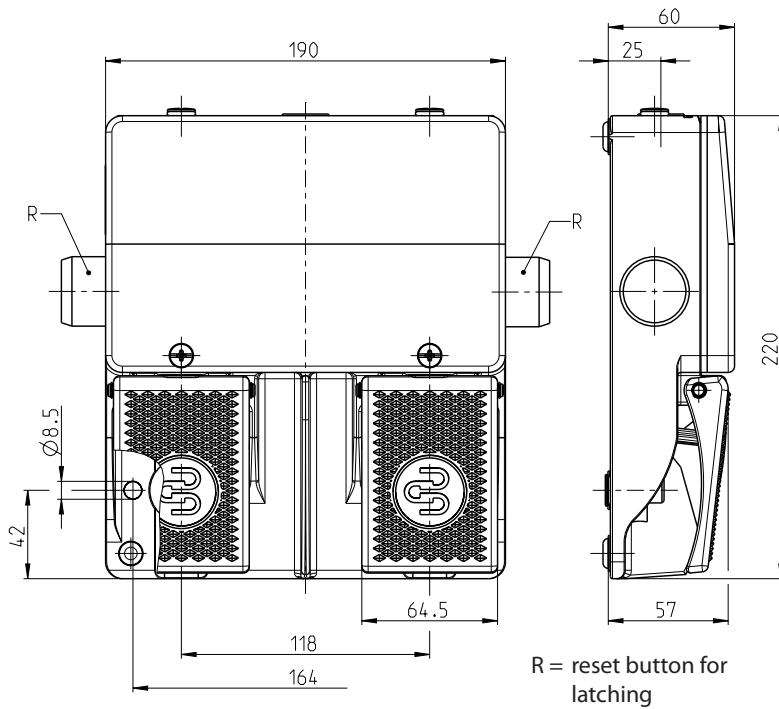

### Switching symbol

Pedal left and right  
(Three-Step-Safety Switch with latch „Off-On-OFF“)

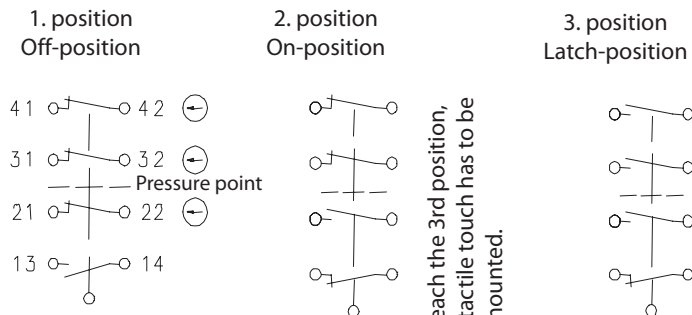

To reach the 3rd position, the tactile touch has to be surmounted.

| Electrical Data                 |           |                                   |
|---------------------------------|-----------|-----------------------------------|
| Rated insulation voltage        | $U_i$     | 250 V AC                          |
| Conv. thermal current           | $I_{the}$ | 10 A                              |
| Rated operational voltage       | $U_e$     | 240 V                             |
| Utilization category            |           | AC-15, $U_e / I_e$ 240 V AC / 3 A |
| Direct opening action           | ⊙         | acc. to IEC/EN 60947-5-1, annex K |
| Short-circuit protective device |           | Fuse 2 A gG                       |
| Protection class                |           | I                                 |

| Mechanical data                      |  |
|--------------------------------------|--|
| Enclosure                            | AL, die-cast   |
| Cover                                | AL, die-cast   |
| Actuator                             | Foot lever (PA)  |
| Ambient air temperature              | -30 °C to +80 °C   |
| Contact type                         | 6 NC, 2 NO. (Zb)   |
| Operating force (pedal centre)       | 10 N   |
| Pressure point                       | ≈ 200 N  |
| Mechanical life                      |  |
| without actuating the pressure point | 10 x 10 <sup>6</sup> operating cycles  |
| with actuating the pressure point    | 1 x 10 <sup>6</sup> operating cycles   |
| Switching frequency                  | max. 30/min  |
| Assembly                             | 2 x M8   |
| Connection                           | screw connections (M3,5)   |
| Number of connection                 | 16   |
| Protection ground                    | 2 x M4   |
| Conductor cross-sections             | Solid: 0,5 ... 1,5 mm <sup>2</sup><br>Litz wire with ferrules: 0,5 ... 1,5 mm <sup>2</sup> |
| Cable entrance                       | 1 x M20 x 1,5  |
| Weight                               | ≈ 1,7 kg   |
| Protection type                      | IP65 in accordance with IEC/EN 60529   |

| ID for safety engineering |                                   |
|---------------------------|-----------------------------------|
| B10d                      | 20 x 10 <sup>6</sup> Schaltspiele |

| Regulations |  |
|-------------|--|
|             | VDE 0660 T100, DIN EN 60947-1, IEC 60947-1     |
|             | VDE 0660 T200, DIN EN 60947-5-1, IEC 60947-5-1 |
|             | DIN EN ISO 13849-1                             |

| EU Conformity |                              |
|---------------|------------------------------|
|               | acc. to directive 2006/42/EG |

**Function**

Three-stage safety switch with latching

The safety contact element consists of two adjoining switching systems which guarantee a normal work flow and in the case of an emergency the safety function "emergency-stop".

1. The normal work flow is initiated by pressing down the pedal to the pressure point, whereby the contacts 13 – 14 are closed and 21 – 22 are opened in succession.
2. In the case of an emergency, the pedal is pressed as far as it will go beyond the pressure point. The NC contacts (31 – 32 and 41 – 42) are force-opened and thereby the work process stops. At the same time, the automatic latching function is activated and holds the contacts (31 – 32 and 41 – 42) in "emergency-stop position". This reliably prevents uncontrolled restart of the machine or moving parts.

Safety for man and machine!

3. Only after the release of the pushbuttons on the side of the enclosure, the contacts will be released again and can be closed again by pressing the pedal beyond resistance of the pressure point.

The working process continues.

**Approvals**

cULus

**Notes**

The degree of protection specified (IP code) applies only to a properly closed cover and the use of an equivalent cable gland with adequate cable.