

Technical Data

Foot-switch

Series F1

Description **F1-SU1ZCA2ZDR UN**

Article number **6161000702**

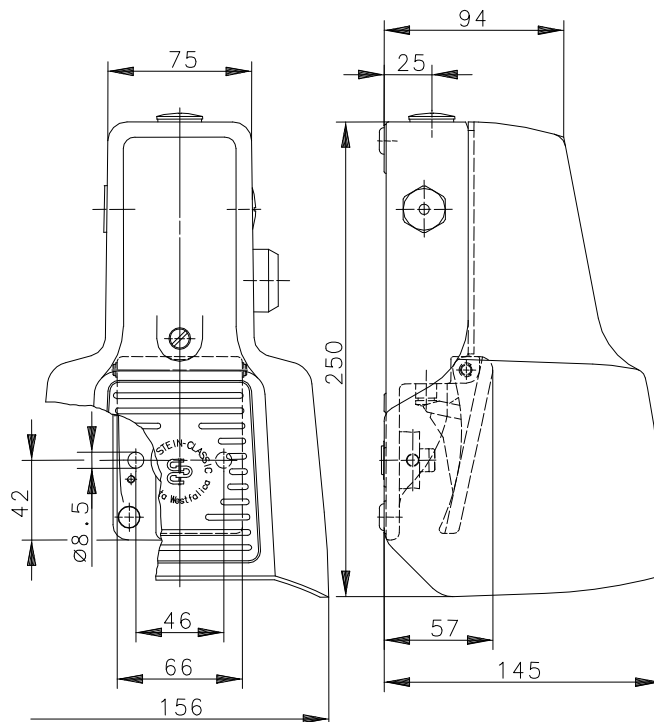

Switching symbol

(Three-Step-Safety Switch with latching function „Off – On – Off“)

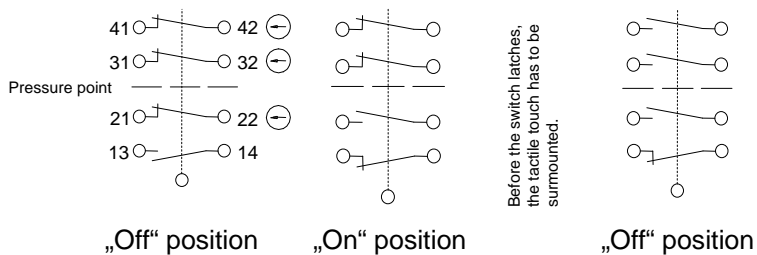

Electrical data

Rated insulation voltage	U_i	250 V AC
Conv. thermal current	I_{the}	10 A
Rated operational voltage	U_e	240 V
Utilization category		AC-15, U_e/I_e 240 V / 3 A
Direct opening action	⊖	acc. to IEC/EN 60947-5-1, Annex K
Short-circuit protective device		Fuse 2 A gG
Protection class		I

This document will not become the contractual basis; the details included herein do not constitute any descriptions of expected conditions, so that warranties/claims for defects on account of possible variations of the actual qualities from the qualities described herein are explicitly excluded. All rights reserved. Specifications subject to change without notice!

Date of issue: 10.12.2012 / Page 1 of 2
Document: 6161000702_en / Status: 3 / 2522-12

Mechanical data	
Enclosure	AL, die-cast
Protective guard (Accident protection cover UN)	AL, die-cast
Actuator	Foot lever (PA)
Ambient air temperature	-30 °C to +80 °C
Contact type	3 N.C, 1 N.O. (Zb)
Operating force	≈ 10 N (pedal centre)
Pressure point	≈ 460 N
Mechanical life	
Sequence of the switching position: Off, On, Off	3 x 10 ⁶ operating cycles
or: Off, On, Latch, Off	1 x 10 ⁶ operating cycles
Switching frequency	Max. 30/min
Assembly	2 x M8
Connection	screw terminals (M3,5)
Number of connections	8
Protection ground	2 x M4
Conductor cross-sections	Solid: 0,5 ... 1,5 mm ² Litz wire with ferrules: 0,5 ... 1,5 mm ²
Cable entrance	3 x M20x1,5
Weight	≈ 2,2 kg
Protection type	IP65 in accordance with IEC/EN 60529

Regulations	VDE 0660 T100, DIN EN 60947-1, IEC 60947-1 VDE 0660 T200, DIN EN 60947-5-1, IEC 60947-5-1
--------------------	--

EU Conformity	acc. to directive 2006 / 95 / EG
----------------------	----------------------------------

Approvals	DGUV CCC
------------------	-------------

Safety function (Foot lever)

Three stage safety footswitch with latch
The safety footswitch contacts are wired in series, this allows normal machine operation with the advantage of a safety latched „Emergency stop“ if the pedal is fully depressed.

1. Rest-Machine stopped.
2. Machine start is enabled by depressing pedal to the pressure point, this closed the normally open contacts 13-14 and opened the normally closed contacts 21-22.
3. In an emergency, the pedal is fully depressed (beyond the pressure point). The normally closed contacts 31-32 and 41 – 42 are force disconnected stopping the machine, simultaneously the latch engages and holds the contacts 31-32 and 41-42 in this “Emergency stop” status, preventing an unauthorised re-start of the machine.
„Safety for man and machine“

3. Only after releasing the latch, by pressing the push button mounted in the side of the footswitch body, do the contacts reset allowing normal operation to resume.

Notes

The degree of protection specified (IP code) applies only to a properly closed protective guard and the use of an equivalent cable gland with adequate cable.

This document will not become the contractual basis; the details included herein do not constitute any descriptions of expected conditions, so that warranties/claims for defects on account of possible variations of the actual qualities from the qualities described herein are explicitly excluded. All rights reserved. Specifications subject to change without notice!