

Foot-switch
Series FS2

Description **FS2-000-000-0-0**

Article number **6160700025**

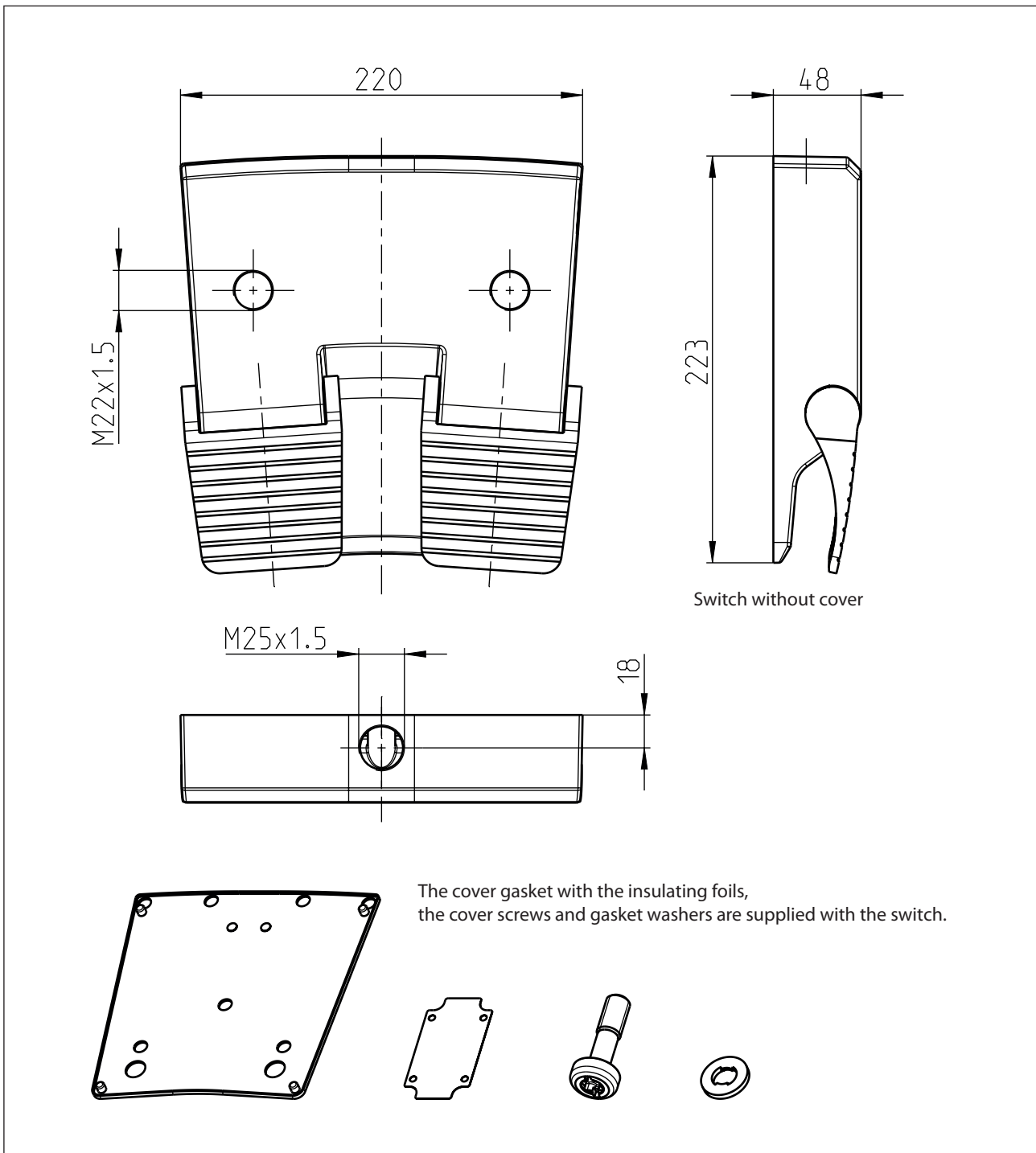

Mechanical data		
Enclosure		AL, die-cast (powder-coated), RAL 5002 (Ultramarine blue)
Actuator		1 pedal (thermoplastic) RAL 7036 (Platinum grey)
Ambient air temperature @ $t = \infty$		$-10\text{ °C} \leq T \leq +80\text{ °C}$
	$t \leq 2\text{ h}$ (cleaning)	$-10\text{ °C} \leq T \leq +95\text{ °C}$
Normal use condition	temperature	$+10\text{ °C} \leq T \leq +40\text{ °C}$
	air humidity	5 % ... 95 % - no condensation
	atmospheric pressure	700 hPa ... 1060 hPa
Storage and transport condition	temperature	$-20\text{ °C} \leq T \leq +80\text{ °C}$
	air humidity	5 % ... 95 % - no condensation
	atmospheric pressure	700 hPa ... 1060 hPa
Protection ground		2 x M4
Cable entrance		1 x M25 x 1,5
Weight		$\approx 1,13\text{ kg}$

EU Conformity	
	acc. to directive 2011/65/EU (RoHS)